

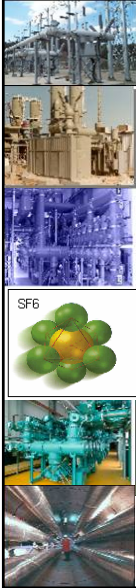

IEEE/PES Substation Committee - GIS Subcommittee







IEEE

Substations Committee Working Group K2 Module

Gas Insulated Substation (GIS) Applications

T&D Chicago GIL

- 1 -



IEEE/PES Substation Committee - GIS Subcommittee



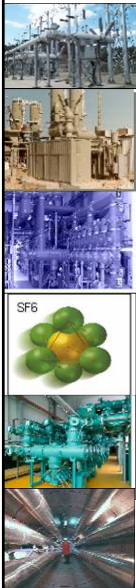

Applications Jacksonville

- Jacksonville, Florida, USA
- Ratings

U_r	138 kV
I_r	2500 A
U_{BIL}	650 kV
I_s	50 kA

T&D Chicago GIL





- 2 -



IEEE/PES Substation Committee - GIS Subcommittee

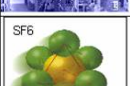

Applications Jacksonville





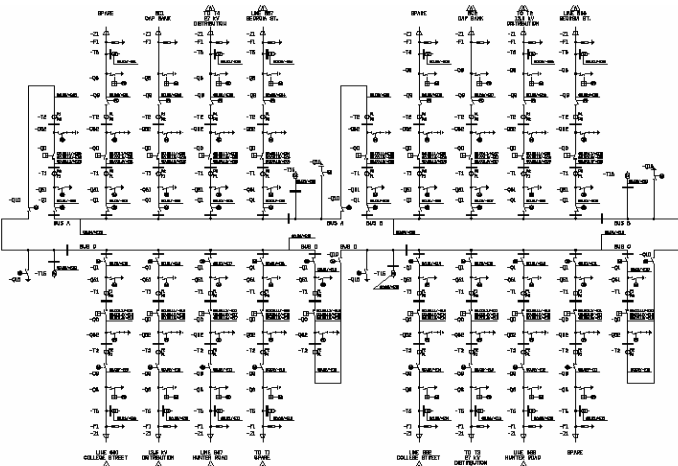



Single Line



T&D Chicago GIL







- 3 -



IEEE/PES Substation Committee - GIS Subcommittee



Applications Jacksonville

Southside Substation – Physical Arrangement

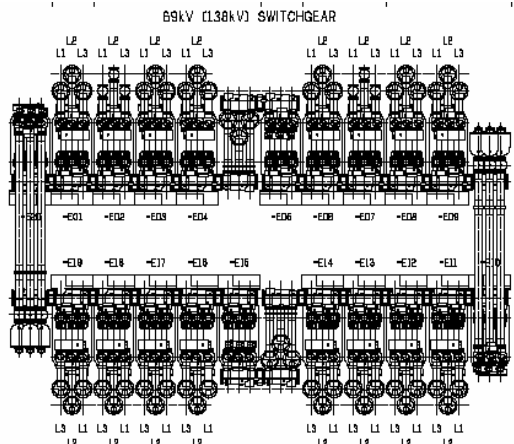

T&D Chicago GIL





- 4 -

IEEE/PES Substation Committee - GIS Subcommittee



Applications Jacksonville





View of the substation building



View into one half of the GIS ring bus solution

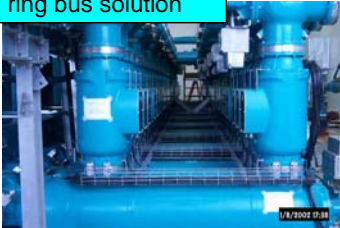

View of local control cubicle (LCC) in the center walkway



T&D Chicago GIL
- 5 -

IEEE/PES Substation Committee - GIS Subcommittee



Applications Jacksonville











23/7/2002 12:57

T&D Chicago GIL
- 6 -



Applications Taylor Street

- Taylor Street, Chicago, USA, ComEd

- Ratings

U_r	362 kV
I_r	4000 A
U_{BIL}	950 kV
I_s	63 kA

- Single line, physical arrangement

T&D Chicago GIL

- 7 -

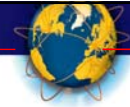

Applications Taylor Street



GIS Substation
Taylor Street, Chicago,
USA, ComEd
362 kV/63 kA, 4000 A



T&D Chicago GIL

- 8 -



Applications Puget Sound

- Puget Sound, Bow Lake Substation, USA
- Ratings

U_r	145/115 kV
I_r	2000 A
U_{BIL}	650 kV
I_s	40 kA

T&D Chicago GIL

- 9 -



Applications Puget Sound

Plan View

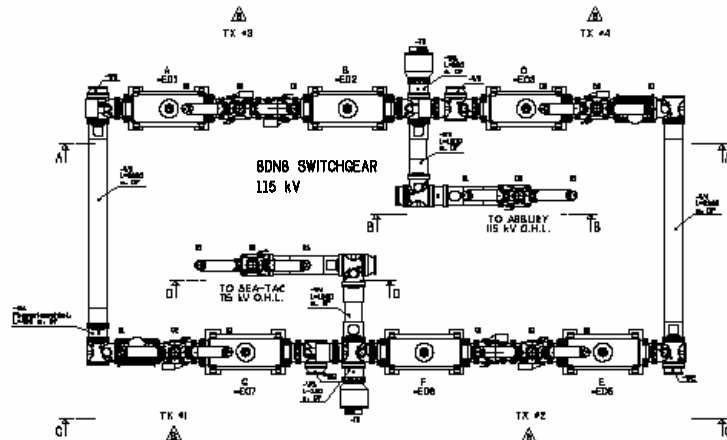

T&D Chicago GIL

- 10 -

IEEE/PES Substation Committee - GIS Subcommittee



Applications Puget Sound



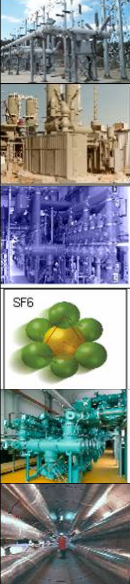

SF6

Physical Arrangement

SECTION C-C

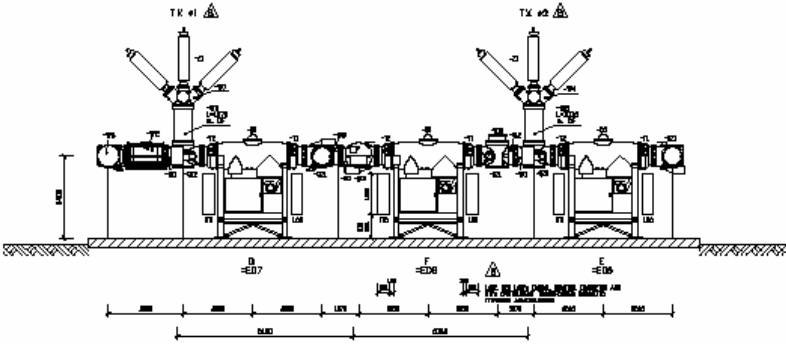

T&D Chicago GIL

- 11 -

IEEE/PES Substation Committee - GIS Subcommittee



Applications Puget Sound

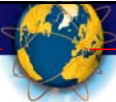

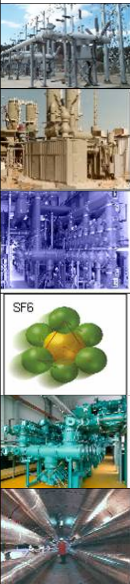

SF6

View of the small spot for the GIS substation



2001/04/22

Connection to overhead lines



Installation – view of 3 phase busbar section



T&D Chicago GIL

- 12 -

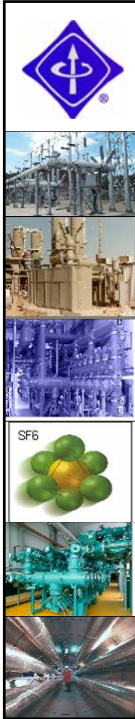
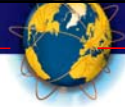

Applications Termobahia

- Termobahia - Rio de Janeiro, Brazil

Ratings

U_r	245 kV
I_r	2000 A
U_{BIL}	1050 kV
I_S	40 kA

- GIS modules with potential transformers outdoor installation

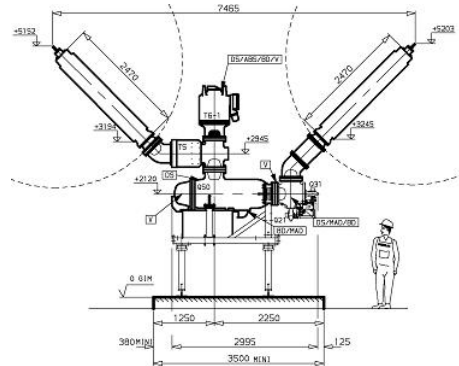

T&D Chicago GIL

- 13 -

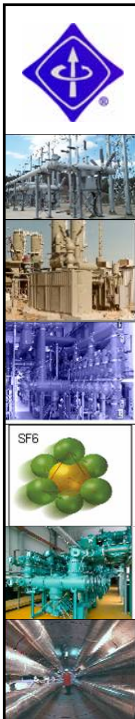
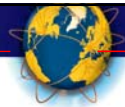

Applications Termobahia

Overview Picture

- Modules have been selected by customer as optimized solution for retrofitting the existing AIS substation.
- There is no advanced condition monitoring installed.









T&D Chicago GIL

- 14 -



IEEE/PES Substation Committee - GIS Subcommittee



Applications Termobahia



Potential transformers have been installed on the module itself.







T&D Chicago GIL

- 15 -



IEEE/PES Substation Committee - GIS Subcommittee



Applications Braintree

- Braintree
- Ratings

U_r	115/13.8 kV
I_r	2000 A
U_{BIL}	550 kV
I_s	31,5 kA
- Single line, physical arrangement
2 lines tie breaker

T&D Chicago GIL

- 16 -

IEEE/PES Substation Committee - GIS Subcommittee

Applications Braintree





















T&D Chicago GIL
- 17 -

IEEE/PES Substation Committee - GIS Subcommittee

Applications Braintree









T&D Chicago GIL
- 18 -

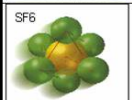

Applications Barbana



- Barbana

- Ratings

U_r	145 kV
I_r	2000 A
U_{BIL}	650 kV
I_s	40 kA

- Single line, physical arrangement
The GIS and Transformers are located under an public park.
The substation supplies the inner city with energy.

T&D Chicago GIL

- 19 -

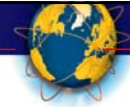

Applications Barbana

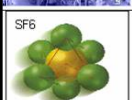







T&D Chicago GIL

- 20 -





IEEE/PES Substation Committee - GIS Subcommittee











Applications

Barbana









T&D Chicago GIL - 21 -



IEEE/PES Substation Committee - GIS Subcommittee



Application

Alabama Avenue

- Project Name Alabama Avenue
- Customer Potomac Electric Power Co. (PEPCO)
- Location Washington D.C.
- Ratings

U_r	230 kV
I_r	2000 A
BIL	
I_s	50 kA

- 3 bays with single busbar and direct parallel connection to transformers and HPFF cables on each feeder.







T&D Chicago GIL - 22 -



IEEE/PES Substation Committee - GIS Subcommittee



Application Alabama Avenue



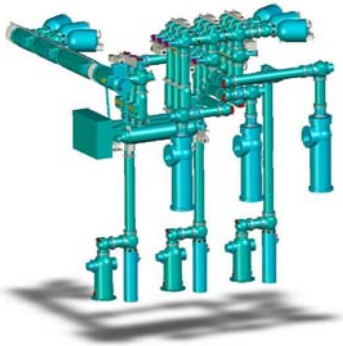









T&D Chicago GIL
- 23 -

IEEE/PES Substation Committee - GIS Subcommittee



Application Alabama Avenue











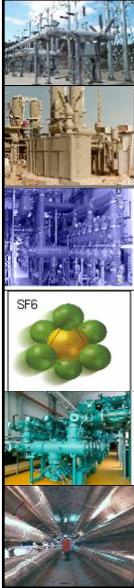

T&D Chicago GIL
- 24 -



Application Rowan University Substation



- Project Name Rowan University Substation
- Customer Rowan University
- Location Glassboro/NJ

- Ratings

U_r	69 kV
I_r	2000 A
BIL	350 kV
I_s	40 kA

- 4 breaker ring arrangement with double cable connections, installed outdoor, incl. control & protection

T&D Chicago GIL

- 25 -

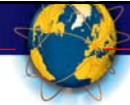

Application Rowan University Substation

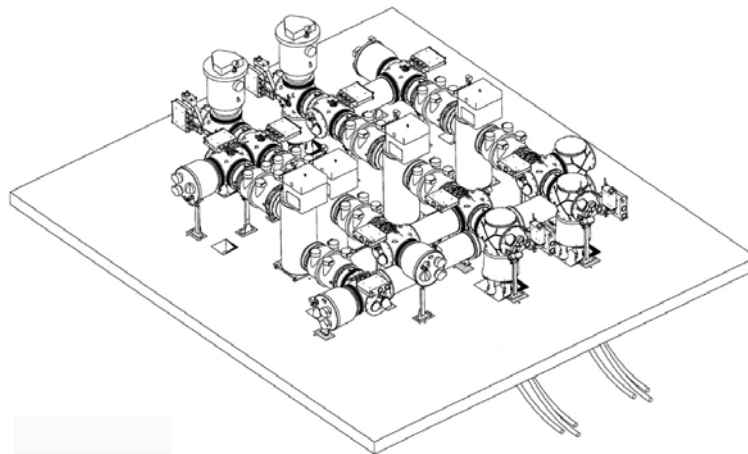
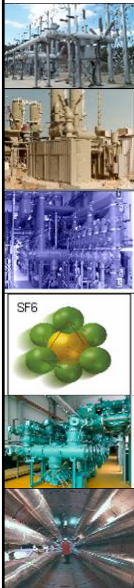

T&D Chicago GIL

- 26 -



Applications West Loop

- Project Name TSS 148 "West Loop"
- Customer Exelon / ComEd
- Location Chicago/IL

- Ratings

U_r	345 kV
I_r	3150 kV
BIL	1050 kV
I_s	63 kV

- 5 bays type 8DQ1 in ring bus arrangement with double cable connections and SF6-air-bushings to the transformers. Prepared for future extension with another 5 bays.

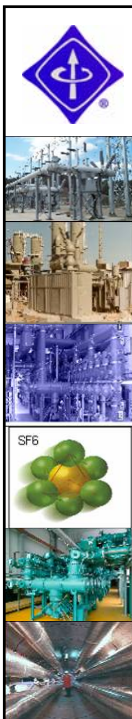

Application West Loop



IEEE/PES Substation Committee - GIS Subcommittee



Application West Loop



















T&D Chicago GIL
- 29 -

IEEE/PES Substation Committee - GIS Subcommittee



Application West Loop

Special features:

The substation TSS 148 West Loop is part of a large project for the reinforcement of the Chicago power supply. Upon request of the customer the delivery and erection was accelerated three months.

T&D Chicago GIL
- 30 -