



Cutler-Hammer

**Characteristics of Different Power Systems Neutral
Grounding Techniques: Fact & Fiction**

By
David Shipp Cutler-Hammer
Frank Angelini Cutler-Hammer

**Originally presented at the IEEE 1988 Industry Applications Society
Technical Conference in
Pittsburgh, PA**

The authors, are currently employed by Cutler-Hammer, a Division of Eaton Corporation
David Shipp is located in Warrendale, Pennsylvania USA
Frank Angelini is located in Philadelphia, PA USA

Characteristics of Different Power Systems Neutral Grounding Techniques: Fact & Fiction

D.D. Shipp Cutler-Hammer, Pittsburgh, Pa.
F.J. Angelini Cutler-Hammer, Philadelphia, PA

ABSTRACT

Power Systems Grounding is probably the most misunderstood element of any Power Systems design. Therefore, this paper will review the characteristics of different Power Systems Grounding techniques as currently applied -- and misapplied within industry today. In many cases, misunderstood concepts and perceptions of the purpose and type of Power Systems Grounding to be selected dates back to the 1940's and earlier. Since that time much research, coupled with experience, has taken place that is now available to industry. This paper will review the many different system grounding practices and present information on different grounding methods. Safety, National Electric Code requirements, and operational considerations, such as continuity of service, will be investigated. Finally, examples of proper applications within various industries will be given.

INTRODUCTION

Historically, the method of system grounding selected for various electrical system settings, e.g. industrial, commercial, etc., dates back to the early part of this century when only two methods were considered: solid grounded and ungrounded. Solid grounding with its advantage of high fault levels to drive protective devices had equally significant disadvantages such as dangers posed by arcs in hazardous areas. Also, the issue of service continuity of critical loads pointed away from this grounding method. The perception that ungrounded systems provide service continuity, at least through the first ground fault, strongly suggested ungrounded systems.

In more recent times, however, well accepted, if not misapplied grounding techniques utilizing resistance or reactance, have provided the power systems engineer other alternatives. These techniques as well as solidly grounded and ungrounded systems will be examined next.

PRESENT PRACTICE

Industrial/Commercial

With very few exceptions, industrial or commercial power systems grounding is dictated by article 250 of the National Electric Code (NEC). The notable exceptions are Power Companies and Mining Systems.

Article 250 dictates which systems must be grounded (solid grounding implied), how they are to be grounded,

sizing of grounding conductors, bonding of all metallic housings or raceways, which systems "shall be permitted to be grounded" as well as the conditions in which isolation or insulation may be substituted for grounding.

The driving influence within the NEC (written by the National Fire Protection Association) for electrical system grounding is best summed up by the 2 fine print notes (FPN) of "article 250-1. Scope"

(FPN): Systems and circuit conductors are grounded to limit voltages due to lightning, line surges, or unintentional contact with higher voltage lines, and to stabilize the voltage to ground during normal operation. Systems and circuit conductors are solidly grounded to facilitate overcurrent device operation in case of ground faults.

(FPN): Conductive materials enclosing electrical conductors or equipment, or forming part of such equipment, are grounded to limit the voltage to ground on these materials and to facilitate overcurrent device operation in case of ground faults.--

Equipment, buildings/premises and personnel safety are of utmost concern. To accomplish safety as implied by the FPN, the NEC requires grounding conductors to extend from the source to the most remote part of the electrical system at that voltage level and to be bonded to all metallic enclosures and raceways. These grounding conductors comprise a key element of equipment grounding and are required for all grounded systems; not just solid grounded systems. Article 250-5 contains the specifics regarding the voltage levels also found in the majority of industrial/commercial power systems. Excerpts of article 250-5, as applicable to industry are as follows:

Art. 250-5

Alternating-Current Circuits and Systems to be Grounded. AC circuits and systems shall be grounded as provided for in (a), (b), (c) or (d) below. Other circuits and systems shall be permitted to be grounded.

- (a) Alternating-Current Circuits of Less than 50 Volts. AC circuits of less than 50 volts shall be grounded under any of the following conditions:
 - (1) Where supplied by transformers if the transformer supply exceeds 150 volts to ground.

- (2) Where supplied by transformers if the transformer supply system is ungrounded.
- (3) Where installed as overhead conductors outside of buildings.

(b) Alternating-Current Systems of 50 volts to 1000 volts. AC systems of 50 volts to 1000 volts supplying premises wiring and premises wiring systems shall be grounded under any of the following conditions:

- (1) Where the systems can be so grounded that the maximum voltage to ground on the ungrounded conductors does not exceed 150 volts.
- (2) Where the system is 3-phase, 4-wire, wye connected in which the neutral is used as a circuit conductor.
- (3) Where the system is 3-phase, 4-wire delta connected in which the midpoint of one phase is used as a circuit conductor.
- (4) Where a grounded service conductor is uninsulated in accordance with the exceptions in sections 230-22, 230-30, and 230-41.

Exception 1. electric furnaces.

Exception 2. rectifiers/adjustable speed drives.

Exception 3. Separately derived systems supplied by transformers with a primary rating < 1000 volts and:

- a. used exclusively for control.
- b. qualified maintenance and supervision.
- c. control power continuity is required.
- d. ground detectors installed.

Also in recognition of its acceptance, high resistance grounded systems are treated thusly:

Exception No. 5: High-impedance grounded neutral systems in which a grounding impedance, usually a resistor, limits the ground fault current to a low value. High impedance grounded neutral systems shall be permitted for three-phase AC systems of 480 volts to 1000 volts where all of the following conditions are met:

- (a) The conditions of maintenance and supervision assure that only qualified persons will service the installation.
- (b) Continuity of power is required.
- (c) Ground detectors are installed on the system.
- (d) Line-to-neutral loads are not served.

(c) Alternating-Current systems of 1 KV and over-- where supplying other than portable equipment, such systems shall be permitted to be grounded.

Where such systems are grounded, they shall comply with the applicable provisions of this article.

Although high impedance grounding has always been permitted by the NEC for systems with line-to-neutral voltages in excess of 150 volts, exception no. 5 was added in the 1987 NEC to clarify a common misinterpretation. As all types of system grounding are developed further in the ensuing sections, it should be noted that older industrial system voltages of 440 volts are analogous to 480 volt systems.

SAFETY AND OPERATIONAL CONSIDERATIONS

There are some safety and operational aspects that should be addressed. We would like to briefly consider a few of these. One of the real hazards with an ungrounded system is the occurrence of a second ground fault. Although nothing happens after a single ground fault, the second ground fault acts like a phase-to-phase fault. Therefore it is important to remove ground faults from ungrounded systems as soon as possible. This is often difficult and is usually done by trial and error. Ground fault location is much simpler on a high resistance grounded system. The ability to locate and rapidly remove ground faults helps to make a high resistance grounded system safer and more reliable than an ungrounded system.

Another area that should be addressed is safety. Many people are of the opinion that an ungrounded system is safer. This opinion says that since contact with a single phase does not complete a circuit, you will not get shocked. Although theoretically true, this is not the case in the real world where there is always capacitive coupling to ground. Personnel safety and the possibility of fire are not significantly different between an ungrounded system and a high resistance grounded system under solid ground fault conditions. Differences do occur under arcing ground fault conditions. These will be addressed later in this paper.

Another area of consideration is continuity of service. A high resistance grounded system limits the ground fault current to a value only slightly higher than an ungrounded system. These values are small enough that it is acceptable to not trip safety devices and let faults remain on the system. The advantages of high resistance grounded systems are the easier location of the fault and the elimination of transient overvoltages which can lead to premature insulation failure.

DEFINITIONS

In order to establish a common perspective, some definitions and short explanations of terms must be presented. The definitions are taken from the IEEE "Green Book" [Ref.2].

Ungrounded System. A system, circuit, or apparatus without an intentional connection to ground, except through potential indicating or measuring devices or other very high impedance devices. Note; Although called ungrounded, this type of system is in reality coupled to ground through the distributed capacitance of its phase windings and conductors. In absence of a ground fault, the neutral of an ungrounded system under reasonably balanced load conditions will usually be held there by the balanced electrostatic capacitance between each phase conductor and ground.

Grounded System. A system of conductors in which at least one conductor or point (usually the middle wire or neutral point of a transformer or generator winding) is intentionally grounded, either solidly or through an impedance.

Grounded Solidly. Connected directly through an adequate ground connection in which no impedance has been intentionally inserted.

Resistance Grounded. Grounded through an impedance, the principal element of which is resistance.

Inductance Grounded. Grounded through an impedance, the principle element of which is inductance.

Effectively Grounded. Grounded through a sufficiently low impedance, such that X_0/X_1 is positive and less than 3.0 and R_0/X_0 is positive and less than 1.0.

WHAT COMPRISES A GROUND SYSTEM?

A grounding system is isolated from other grounding systems by delta windings in 3 phase systems. It only takes 1 delta winding to accomplish isolation; not both primary and secondary windings. There are 4 separate grounding systems illustrated in Figure 1.

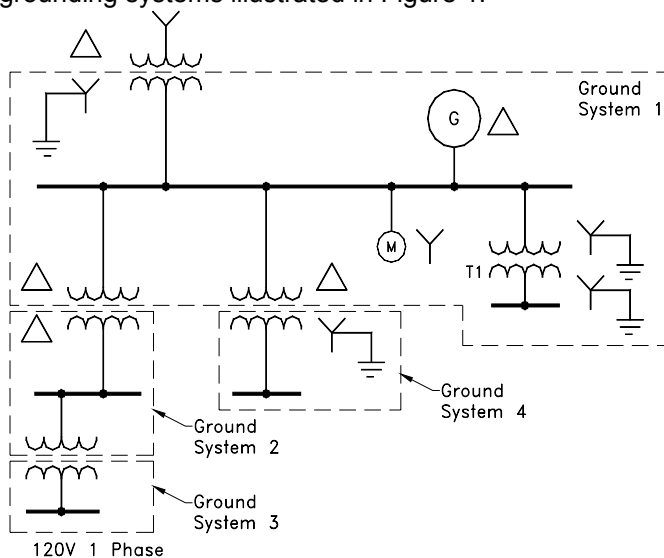

Fig.1 Grounding Systems

System 1 includes all of the 480 volt system including the source generators through all the primary delta windings of the loads. The wye ungrounded motor and wye-wye solidly grounded transformer secondary is also a part of the 480 volt system. Any grounding problem in the secondary of T1 will effect the 480 volt system. In contrast, any grounding problem in grounding systems 2, 3 or 4 will not effect its respective primary grounding system due to its primary delta windings.

As a preface to the subject of system grounding, a close look at all the electrical parameters in the following example, will illustrate the effect grounding has on current and voltage under "bolted" ground fault conditions.

In figure 2, a sustained ground fault occurs on a 480 volt wye connected (could be delta) ungrounded system. Since the system is only, in essence, capacitively coupled to ground through a relatively high impedance, the entire system is displaced above ground as indicated in figure 3b. Figure 3a illustrates the system voltage profile prior to the ground fault condition. The system will remain in this position until the fault is cleared, or another phase breaks down to form a double line-to-ground fault.

Since there is no direct ground path back to the neutral point of the source in figure 3b, the current must return through the distributed capacitance (insulation system) of the 2 unfaulted phases. As indicated, only 1.04 amps will flow. The dashed lines represent the line-to-line voltage relationship so that a delta system can also be visualized.

$$I_{oa}=I_{ob}=(480 V)/-j800\Omega =0.6 \text{ amps}$$

$$(.6) \text{ COS } 30^\circ + (.6) \text{ COS } 30^\circ =1.04 \text{ amps}$$

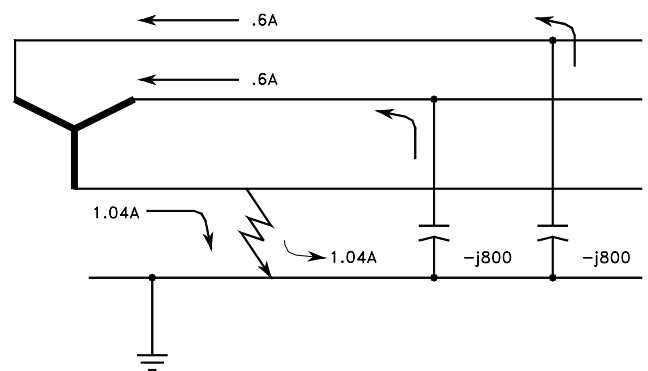

Fig.2 Ground Faults on Ungrounded Systems

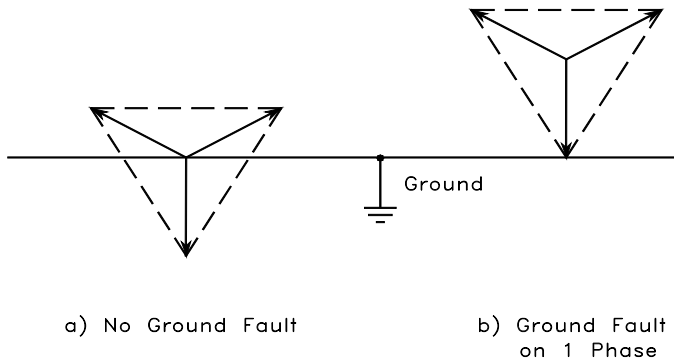

Fig.3 Voltages During Ground Fault

If this system is now solidly grounded at its source (wye connection), the system can now supply 29,200 amps (This data is typical of a 480 volt system served by a 1500 KVA transformer with a 500 MVA primary source) under ground fault conditions as shown in figure 4. Figure 5a shows the voltage profile under normal load conditions (same as figure 3a). Since the neutral point is clamped to the ground system (figure 5b), the B phase source voltage is now shorted out. (Envision the B phase-to-ground voltage shrinking to zero.) Under these conditions, the maximum available fault current will flow.

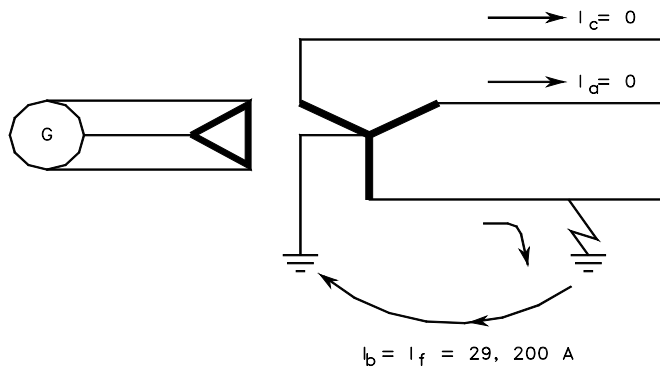

Fig.4: Ground Fault on a Solidly Grounded System

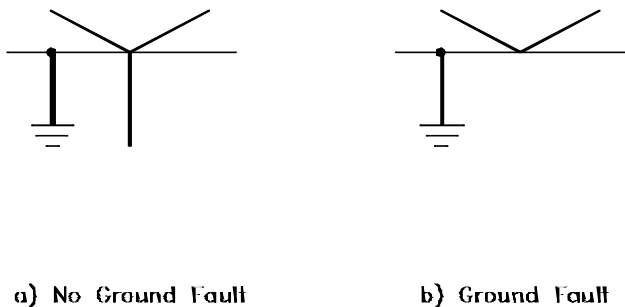

Fig.5: Voltage Profiles for Solidly Grounded System

A comparison of all the voltages and currents of these 2 types of grounding as listed in table I, support the following observations:

- 1) In a solidly grounded system, very high ground fault current is available--but with low or suppressed system voltages.
- 2) In an ungrounded system, the available ground fault current is very low--but the voltage on the normal line-to-ground insulation is increased from a line-to-ground value to a full line-to-line magnitude .

TABLE I

Comparison of System Quantities during a sustained line-to-ground fault on a solidly grounded and ungrounded system.

Voltage	System	
	Grounded	Ungrounded
Phase A to Phase C	480	480
Phase A to Phase B	$480/\sqrt{3}$	480
Phase C to Phase B	$480/\sqrt{3}$	480
Phase A to Ground	$480/\sqrt{3}$	480
Phase B to Ground	0	0
Phase C to Ground	$480/\sqrt{3}$	480
Fault Current - Amperes		
Phase B	29,200	1.04
Phase C	0	.6
Phase A	0	.6

These two examples show the extremes of the common accepted understanding of these types of power system grounding. Other types of system grounding fall between these two extremes. For sustained ground fault conditions (bolted fault), table I is an accurate summary--as far as it goes. However, under arcing ground fault conditions, the system performance characteristics change considerably but this aspect is seldom addressed. System grounding criterion under arcing ground fault conditions, will be expanded upon within the appropriate section to follow.

Although a 480/277V system is used as an example, higher voltage systems follow directly.

TO GROUND THE SYSTEM OR NOT TO GROUND

When the type of grounding to be selected is being addressed within the design stage of an electrical power system, there are 2 key questions which must be considered:

- 1) Are there any line-to-neutral loads?
- 2) How important is service continuity for this electrical system?

The answers to these questions strongly influence the type of grounding selected. Line-to-neutral loads suggest solid grounding; high continuity of service requirements suggest an ungrounded or something approaching an ungrounded system. Additional characteristics with the appropriate discussions will be clarified in the following section.

METHODS OF SYSTEM GROUNDING

Solidly Grounded

Solidly grounded systems are by far the most common found in industrial/commercial power systems today. In many cases, solid grounding (NEC-Article 250-5) is mandated. In others, it is selected based on economics. The 480/277 volt system in figure 6a (typical to commercial buildings such as a hotel) is solidly grounded to permit 277V (line-to-neutral) fluorescent lighting (economics).

For line-to-neutral loads to be applied, the neutral point of the wye connected source must be solidly grounded for the system to function properly and safely. If the system is not solidly grounded, the neutral point of the system would "float" with respect to ground as a function of load subjecting the line-to-neutral loads to voltage unbalances and instability.

The 120/208V wye system in figure 6b must be solidly grounded to comply with the NEC (all systems with line-to-ground voltages of 150 volts or less and for those systems with line-to-neutral loads). It is selected primarily where a lot of 120 volt (line-to-neutral) loads are present (such as a condominium).

The 240/120 volt 3-phase delta system shown in figure 6c (typically light commercial such as a Burger King or McDonald's) must also be solidly grounded to comply with the N.E.C. (the lowest line-to-ground voltage is less than 150 volts).

To insure that these systems are safe, the NEC requires that equipment grounding conductors (bare or green insulated) must extend from the source to the furthest point of the system within the same raceway or conduit. Its purpose is to maintain a very low impedance to ground faults so that a relatively high fault current will flow thus insuring that circuit breakers or fuses will clear

the fault quickly and therefore minimize damage. It also greatly reduces the shock hazard to personnel.

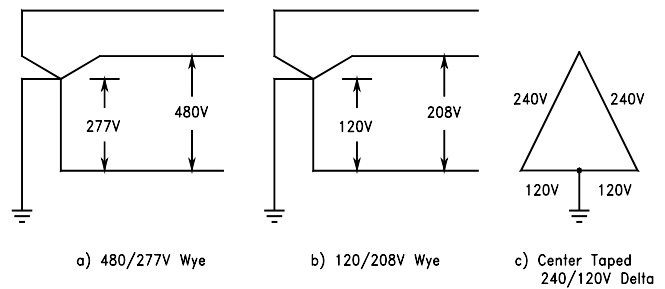

FIG. 6
Solidly Grounded Systems
(Industrial/Commercial)

The logic behind requiring systems with less than 150 volts to ground to be solidly grounded, is that studies, laboratory experiments and case histories [4][7] have shown that it takes about 150 volts across a gap in low voltage systems, to sustain an arc. With less than 150 volts, the arc is generally self healing and rarely continues. Solid grounding in this case provides equipment and personnel safety, permits the application of economical line-to-neutral loads and in the case of a "solid" ground fault, assures prompt actuation of phase protective devices---assuming the equipment grounding function (green insulated or bare connector in same raceway) is intact. The historical incidence of sustained ground faults is so low in 120/208 volt or 120/240 volt systems that the NEC has not found it necessary to require separate system ground fault protection.

Ungrounded

For those systems where service continuity is of primary concern, the ungrounded system historically has been selected. The perception is that ungrounded systems have higher service continuity. This is based on the argument that the ground fault current is small and that negligible burning or heating will occur if the fault is not cleared. Therefore line-to-ground faults can be left on the system until it is convenient to find and clear them. This perception has some validity if you limit your criterion to "bolted" or "hard" faults. However, in the real world, the vast majority of all faults start as low level arcing ground faults. When arcing ground faults are considered, the following conditions surface--but are seldom addressed.

- 1) Multiple Ground Faults
- 2) Resonant Conditions
- 3) Transient Overvoltages

Multiple ground faults can and do occur on ungrounded systems. While a ground fault on one phase of an ungrounded system does not cause an outage, the longer the ground is allowed to remain the greater is the

likelihood of a second ground occurring on another phase because the unfaulted phases have line-to-line voltage impressed on their line-to-ground insulation. In other words, the insulation is overstressed by 73 percent. Also, there is an accelerated degradation of the insulation system due to the collective overvoltages impinged upon it, through successive ground-faults over a period of several years.

Although not that common, resonant conditions may result in ungrounded systems when one phase is grounded through an inductance, for example, a ground within the winding of an instrument transformer. When this happens, the high circulating currents result in high voltages across the unfaulted phases.

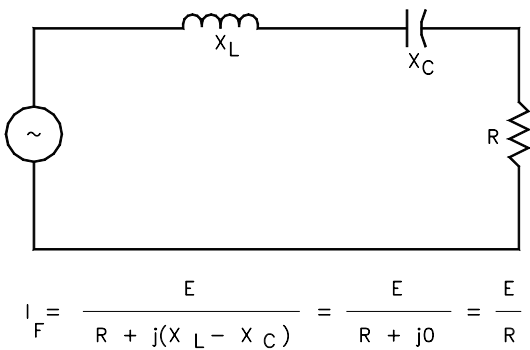

Fig. 7 Series Resonant Circuit (when $X_L=X_C$)

Transient overvoltages due to restriking or intermittent ground faults can and do develop substantial overvoltages on ungrounded electrical systems with respect to ground [Ref. 1]. There have been many documented cases within industry where multiple equipment failures (e.g.-motors) over an entire 480V system have occurred while trying to find and locate a ground fault. Measured line-to-ground voltages of 1200 volts or higher in these instances are not that uncommon. In all instances, the cause has been traced to a low-level intermittent arcing ground fault on an ungrounded system.

The mechanism explaining how this occurs is best explained in conjunction with fig. 8. At point A in time, just prior to a ground fault, the neutral point of the system is at or near ground potential due to the electrostatic charge on the systems' shunt capacitance to ground (insulation, surge capacitors) under balanced load conditions.

Should the A phase conductor become grounded, the system voltages would be displaced as illustrated at point B. At the instant after the fault occurs, when the A phase capacitive charging current (I_{oc}) passes through zero, it is extinguished leaving a trapped charge on the shunt capacitance to ground of A phase. With no path to dissipate this trapped charge, (fixed DC voltage) the system tends to stay in the position shown at point B.

Although the neutral point of the system is at a new reference point, the AC sine wave continues to rotate on a 60 cycle basis. One-half cycle later in time (180 electrical degrees), the A phase is as shown-above the ground plane at point C. The instantaneous voltage across the ground fault is now twice the normal line-to-neutral crest voltage relative to ground potential. The ground fault restrikes across the gap and suddenly yanks the A phase to ground potential. The non-linearity of the arc (high frequency components) will tend to excite the inductance/capacitance of the system resulting in a high frequency oscillation (not shown) between + 200% and - 200%. When the arc extinguishes, the system voltage relationships will tend to remain in a new position with respect to ground potential as shown in the lower part of C. Since the arc current has been extinguished, a new trapped DC charge on the phase A capacitance of - 200% now applies.

In the next 1/2 cycle the AC sine wave will rotate the voltage vectors from point C to the lower part of D (- 200% to -400%) at which time the arc restriks, and the mechanism repeats itself between -400% and +400%. At this point in time the voltages to ground are shown at 5.5 per unit (550%) on the unfaulted phases. If the arc extinguishes, the mechanism will continue. From a practical standpoint, voltages in excess of 700% are rare since most insulation systems break down between 600% and 700%. Bear in mind that these overvoltages are superimposed on the entire electrical system thereby explaining accelerated insulation deterioration and an increasing incidence of ground fault occurrences over time.

Although fig. 8 shows a maximum deviation in just 3 arcs, it might take considerably longer to reach these levels since the arc may restrike before reaching maximum voltages on the AC sine wave. Also, if the fault becomes a "hard" fault at any time during the process, the trapped charges will be dissipated leaving the voltage relationships as shown at point B.

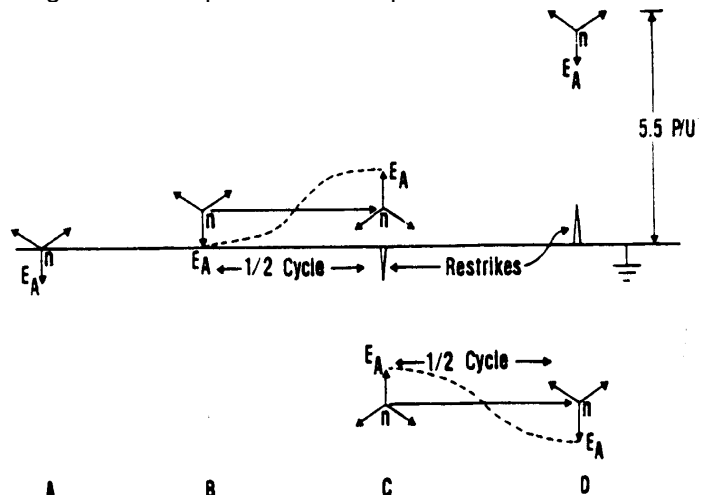
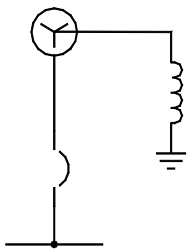

Fig.8 Transient Overvoltages from Restriking Ground Fault

Inductance Grounded

Adding inductive reactance from the system neutral point to ground (fig.9) is an easy method of limiting the available ground fault from something near the maximum 3 phase short circuit capacity (thousands of amperes) to a relatively low value (200 to 800 amperes). However, experience and studies have indicated that this inductive reactance to ground resonates with the system shunt capacitance to ground under arcing ground fault conditions and creates very high transient overvoltages on the system. The mechanism under which this occurs is very similar to that discussed under the ungrounded system characteristics. To control the transient overvoltages, studies have shown that the design must permit at least 60% of the 3 phase short circuit current to flow under ground fault conditions. e.g. A 6000 amp grounding reactor for a system having 10,000 amps 3 phase short circuit capacity available. Due to the high magnitude of ground fault current required to control transient overvoltages, inductance grounding is rarely used within industry.



In reactance grounding, the neutral is connected to ground through a reactor.

Fig.9 Reactance Grounded

Low Resistance Grounded

For large electrical systems where there is a high investment in capital equipment or prolonged loss of service of equipment has a significant economic impact, low resistance grounding has been selected. A resistor is connected from the system neutral point to ground and generally sized to permit only 200A to 1200 amps of ground fault current to flow (Fig. 10a). Enough current must flow such that protective devices can detect the faulted circuit and trip it off-line but not so much current as to create major damage at the fault point. Since the grounding impedance is in the form of resistance, any transient overvoltages are quickly damped out and the whole transient overvoltage phenomena is no longer applicable.

Although theoretically possible to be applied in low voltage systems (e.g. 480V), industrial experience has shown that with a significant amount of the system voltage dropped across the grounding resistor, there is not enough voltage across the arc forcing current to flow, for the fault to be reliably detected. For this reason, low resistance grounding is not used for low voltage systems (under 1000 volts line-to-line).

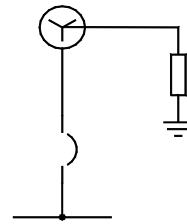

In resistance grounding the neutral is connected to ground through one or more resistors. There are two types of resistance grounding.

- a) Low resistance (200A to 1200A)
- b) High resistance (less than 10A)

Fig.10 Resistance Grounded

High Resistance Grounded

High resistance grounding is almost identical to low resistance grounding except that the ground fault current magnitude is typically limited to 10 amperes or less (fig. 10b). High resistance grounding accomplishes two things. The first is that the ground fault current magnitude is sufficiently low enough such that no appreciable damage is done at the fault point. This means that the faulted circuit need not be tripped off-line when the fault first occurs. It also means that once a fault does occur, you don't know where the fault is located. In this respect, it performs just like an ungrounded system.

The second point however, is significant in the sense that it can control the transient overvoltage phenomenon present on ungrounded systems if engineered properly. The significant difference between its performance and that of an ungrounded system is that when the ground fault arc is extinguished at points C and D in fig. 8, the trapped charge left on the capacitance of the system is continuously dissipated off as heat in the resistor. The result is that the neutral point is held at approximately that position of fig. 3b. For high resistance grounding to be effective, the size of the resistor must be carefully selected for each system [9]. Under ground fault conditions, the resistance must dominate over the system charging capacitance but not to the point of permitting excessive current to flow and thereby excluding continuous operation.

Grounding Transformers

So far this paper has discussed system grounding where the neutral point of the source has been readily available. But what does one do when the neutral point is not available? As the ungrounded system problems became more apparent to industry, they recognized that it was to their advantage to ground their delta connected systems. Some took the approach of purposely grounding one phase. Although somewhat effective for the transient overvoltage criterion, it leaves the system with the continuous line-to-line overvoltage condition and the multiple fault (line-to-line) problems mentioned previously.

The best way to ground an ungrounded delta system (existing or new) is to derive a neutral point through grounding transformers. This may be accomplished in one of two ways as shown in fig. 11.

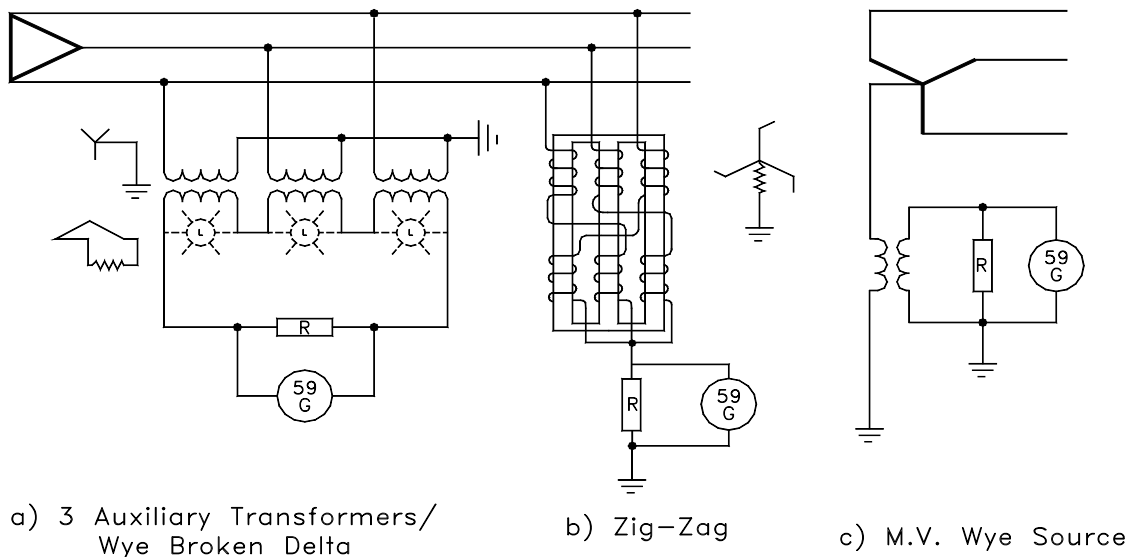

Fig.11 Grounding Transformers

In fig. 11a, high resistance grounding is accomplished through three auxiliary transformers connected wye-broken delta. The resistor inserted in the "broken delta" leg is reflected to the primary under ground fault conditions and limits the current to a nominal value as dictated by its design. Under any system condition other than ground faults, the 3 secondary voltages add vectorially to zero. With zero voltage across the resistor, no current flows and the grounding resistor does not impact the system. However, under ground fault conditions, one of the 3 voltages is shorted out and the voltage across the resistor now is no longer zero. Under these conditions, the resistor is now in the circuit and current does flow with the effect of limiting the primary current to the design value. Also, sensing the voltage drop across the resistor (device 59G) can be used to signal an alarm advising that a ground fault has occurred. The 3 lights across each individual transformer will constitute a version of the normal ground detection scheme currently employed on ungrounded systems.

High resistance grounding can also be achieved alternately by a zig-zag grounding transformer as shown in fig. 11b. The scheme in fig. 11a uses the flux in the transformer's iron core to produce secondary voltages with their respective phase relationships as described previously. With the zig-zag transformer, the windings are connected in a zig-zag fashion such that the flux in the iron is vectorially summed opposed to vectorially summing the secondary voltages. Consequently it behaves on the system just as the 3 auxiliary transformers do. It appears "transparent" to the system except under ground fault conditions. The resistor makes it resistance grounded.

In both of these cases, either approach accomplishes the same end. Therefore, selection should be based on space, weight, size and/or economics as applicable to the system in question.

Although high resistance examples are shown, other variations are available for higher voltage systems.

The Effect of Grounding Impedance on Transient Overvoltage

It was noted earlier in this paper that arcing ground faults could produce high transient overvoltages with disastrous effects on system equipment and dangers to operating personnel. Studies [Ref. 8] have examined the relationship between the grounding method employed and desirable ratio of sequence network impedances, e.g. X_0/X_1 , R_0/X_0 . Due to the transitory nature of the arcing ground fault, a high frequency component remains somewhat constant while the 60 hertz component varies directly with the system grounding impedances. For low magnitudes of X_0 the ground fault current magnitude wave form appears as shown in fig. 12a with a normal current zero occurring as expected (60 hertz value). However, when X_0 is increased significantly, the current magnitude decreases significantly (60 hertz component only) which allows the high frequency oscillatory waveform to intersect the zero axis "out-of-step" or at an "abnormal time" as indicated at point B in fig. 12b. This abnormal current zero (sometimes referred to as a virtual zero) allows the normal charge on the system coupling capacitance to discharge at the wrong time. The result is an abnormally high overvoltage condition.

Table II presents the basic association between these system factors and those grounding methods already reviewed.

Fig.12

The Effect of Grounding Impedance on Transient Overvoltage

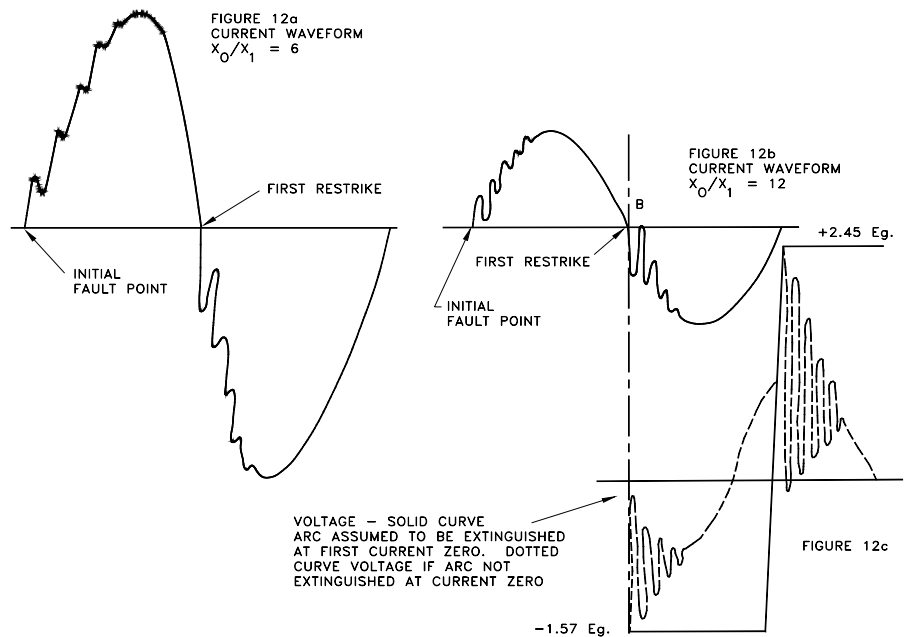

TABLE II

X_0/X_1 and R_0/X_0 Ratios for Low Transient Overvoltage

<u>Grounding Method</u>	<u>Desired X_0/X_1, R_0/X_0 Ratio</u>
Ungrounded	<ul style="list-style-type: none"> o No ratios available o Produces high transient voltages. o Systems grounded through potential transformers included here.
Solid Grounding	<ul style="list-style-type: none"> o X_0/X_1 inherently very low unless wye-wye transformers used.
Reactance Grounded	<ul style="list-style-type: none"> o X_0/X_1 should be kept less than 3.0
Low Resistance Grounded	<ul style="list-style-type: none"> o R_0/X_0 should be equal to or greater than 2.0 o X_0/X_1 should be equal to or less than 20.
High Resistance Grounded	<ul style="list-style-type: none"> o Resistive current value should be sized \geq to the total three-phase capacitive current to ground under ground fault conditions.

Other factors effecting the choice of grounding method include:

Mechanical Stress in Generator Windings - A generator winding is braced to withstand a three-phase fault on its terminals. The unit should be grounded so that the maximum line-to-ground fault current does not exceed this value. This requires X_0/X_1 to be greater than or equal to 1.0 . This is a major factor if generator supplies 4 wire systems without an interposing transformer (exclude 480V generators).

Selective Relaying - in conventional unit generator systems, selective relaying for ground faults is not a problem since the delta-wye transformer effectively isolates the zero sequence circuits. For other systems where selectivity is a problem, provision should be made for sufficient ground fault current to flow to operate the ground relays.

Surge Protection - on ungrounded or high impedance grounded systems, full line-to-line voltage rated arresters must be used. For large systems with extensive application of surge protective measures, considerable savings are available when using 80% arresters. For this rating, the grounding method employed must provide for X_0/X_1 equal to or less than 3.0 and R_0/X_0 equal to or less than 1.0 (effectively grounded).

TECHNICAL SUMMARY

Table III summarizes the characteristics of all the types of system grounding as typically used by industry.

SELECTION CRITERIA

When addressing grounding within the design process, a close look at Table III will assist in the selection process. As mentioned previously, the 2 key considerations, line-to-neutral loads and service continuity, must be the initiation point. It should also be noted that the type of grounding selected for each system or subsystem may be independently addressed with more than one type of system grounding selected within a given electrical system.

For high service continuity requirements, all types of system grounding which require automatic segregation of the faulted zone (e.g. high ground fault current) by operation of a protective device, cannot be a consideration. This leaves ungrounded, ground-fault neutralizer (not discussed due to very limited

applications where almost no switching of loads is permitted) and high resistance grounded systems [Ref. Table III] as viable options. It also precludes line-to-neutral loads.

In some instances, the capacitive charging current of some systems can be substantial. Too much capacitive system charging current may preclude continuous operation (greater than 10 amps) and require breaking the system into subsystems using isolation transformers to apply high resistance grounding (Transient overvoltage failures would be expected to be high on these systems). Economics in this case, however, may require low resistance grounding as the most practical option.

Maintenance of a high resistance grounded system actually can be better than an ungrounded one. Since high resistance grounding controls transient overvoltages, the incidence of grounds on the system should decrease. The techniques used to find and clear grounds are identical to those of an ungrounded system.

**Table III
System Characteristics with Various Grounding Methods**

	Ungrounded	Essentially solid grounding		Reactance grounding	Ground-fault neutralizer	Resistance Grounding	
		Solid	Low-value reactor			High-value reactor	Low resistance
Current for phase-to-ground fault in percent of three-phase fault current	Less than 1%	Varies, may be 100% or greater	Usually designed to produce 60 to 100%	5 to 25%	Nearly zero fault current	5 to 20%	Less than 1%
Transient over-voltages	Very high	Not excessive	Not excessive	Very high	Not excessive	Not excessive	Not excessive
Automatic segregation of faulted zone	No	Yes	Yes	Yes	No	Yes	No
Lightning arresters	Ungrounded neutral type	Grounded-neutral type	Grounded-neutral type if current is 60% or greater	Ungrounded neutral type	Ungrounded neutral type	Ungrounded neutral type	Ungrounded neutral type
Remarks	Not recommended due to over voltages and nonsegregation of fault	Generally used on system (1) 600 volts and below and (2) over 15kV		Not used due to excessive over-voltages	Best suited for high-voltage over-head lines where faults may be self-healing	Generally used on industrial systems of 2.4 to 15kV	Generally used on systems 5kV and below

One variation of high resistance grounding actually improves system maintainability. This variation utilizes a pulsing contactor which momentarily shorts out part of the resistor when it is decided to locate the ground--without tripping circuits off-line and observing the ground detection lights. While the entire system is operating, the pulsing contactor controls are manually energized permitting a cyclic pulse of current (e.g. from 4 amps to 7 amps, back to 4 amps, etc.) to flow. A special sensitive clamp-on ammeter is then put around all 3 conductors of each circuit. The one with the pulse on it is the one grounded. Tracing that circuit further will allow pinpointing the exact fault location. The pulsing contactor

can then be de-energized and the fault cleared when convenient---all without de-energizing any loads.

Medium voltage systems (2.4KV to 5.0KV) can also be high resistance grounded with similar system improvements as those indicated for 480 volt systems. Above 5.0KV service continuity may not always be realized due to corona at the fault location, although the current is very low.

Low resistance grounding (see Fig. 10) is also a viable alternative for medium voltage systems. However it requires tripping of the faulted circuit by protective ground fault devices and the equipment grounding conductor function. For most of Industry, this is the preferred choice.

Solid grounding or effective grounding is the preferred choice for systems supplying 4 wire loads, uninsulated aerial line systems or systems with voltages above 15KV.

CONCLUSIONS

Proper System Grounding of electrical power systems can significantly improve reliability and safety. Retrofits of existing systems can be achieved utilizing grounding transformers as shown in Fig. 11. New systems can be designed using wye connected generators and delta-wye transformers.

The characteristics of different grounding techniques set forth in this paper should provide an intelligent basis for proper selection consistent with the needs of the power system in question.

REFERENCES

1. D. Beeman, Industrial Power Systems Handbook, McGraw-Hill, 1955
2. IEEE std. 142-1982, "IEEE Practice for Grounding of Industrial and Commercial Power Systems" (IEEE Green book), IEEE, NY, NY.

3. IEEE std. 141-1986, "IEEE Recommended Practice for Electric Power Distribution for Industrial Plants" (IEEE Red book), IEEE, NY, NY.
4. J. R. Dunki-Jacobs, "The Escalating Arcing Ground Fault Phenomenon", IEEE Transactions on Industry Applications, Nov./Dec., 1986.
5. The National Electrical Code Handbook; NFPA, 1987.
6. Using the National Electrical Code; Grounding, Instructors' Guide," NFPA, 1981.
7. C. L. Wagner, "Grounding Report II", Effect of Grounding Impedance on the Magnitude of Transient Overvoltage Due to Arcing Grounds", Westinghouse Transmission and Distributions Systems, 1960.
8. Electrical Transmission and Distribution Reference Book, Westinghouse Electric Corp., 1964.
9. Industrial Power Systems Data Book, General Electric Company, 1956.
10. "System Neutral Grounding and Ground Fault Protection Guide", (PRSC-4E), ABB Corp., Coral Springs, FL., Feb., 1986.