



The Albuquerque IEEE Joint Chapter Presents

TOPIC OF TALK: What Is Intentional Electromagnetic Interference (IEMI), and Why Should We Worry?

PRESENTED BY: Dr. William A. Radasky, President, Metatech, Inc.

TIME: 7:30 pm, Thursday, February 21, 2008
Social begins at 5:45 pm
Dinner begins at 6:30 pm

PLACE: Four Hills Country Club, 911 Four Hills Road, SE, Albuquerque, NM 87123

DINNER: Herb-Crusted Sea Bass with Citrus Cream Sauce, salad, & dessert
(Vegetarian pasta entrée available by request at time of RSVP)

COST: No charge, no reservation required to attend just the talk.
\$20 per person for dinner (full-time students, \$10)—reservation required.
RSVP by email to ABQ_Joint_Chapter@IEEE.org
or phone Leland Bowen at (505) 867-2731.

**Reservations & cancellations accepted until NOON, Monday,
February 18th.**

ABSTRACT OF TALK:

In 1999 two events occurred that stimulated the serious study of the problem of criminals or terrorists using electromagnetic weapons to attack commercial systems for financial or other reasons. In February 1999 an important workshop was held at the EMC Symposium in Zurich, Switzerland dealing with EM Terrorism. Later that year URSI decided to approve a resolution to deal with the threat of "Criminal Activities Using Electromagnetic Tools." Later in 2005, the International Electrotechnical Commission (IEC) finished the most comprehensive EMC standard dealing with the subject of IEMI (Intentional Electromagnetic Interference). Since the late 1990s an international effort has begun to understand the threat of IEMI (including both narrowband and wideband threats) in terms of its impact on common electronic systems. Research has dealt with different types of threat waveforms, different types of equipment (including networked systems), and with different ways to protect civil electronics from this emerging threat. This presentation will review the early history of IEMI, the definitions used today, samples of threat weapons, susceptibility results from testing, and finally protection approaches planned for coverage by future IEC standards.

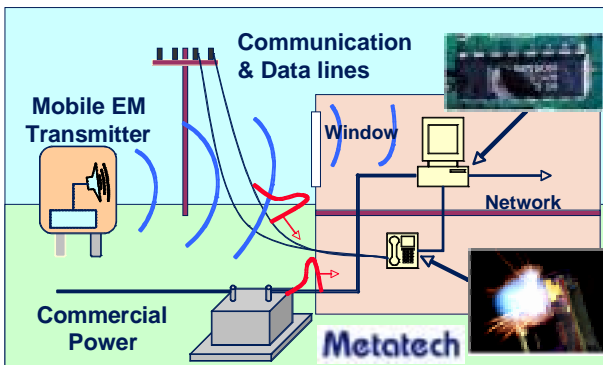

Geometry of an IEMI attack

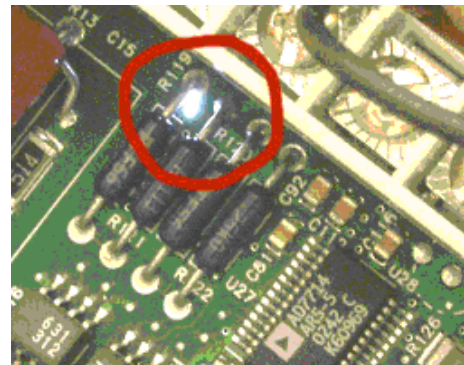

Circuit board arc due to IEMI

SPEAKER'S BIOGRAPHY:



William A. Radasky received the B.S. degree with a double major in Electrical Engineering and Engineering Science from the U.S. Air Force Academy in 1968. He also received the M.S. and Ph.D. degrees in Electrical Engineering from the University of New Mexico in 1971 and from the University of California, Santa Barbara in 1981, with an emphasis on the theory and applications of electromagnetics. He has worked on EMP research projects for DASA, DNA, DSWA and DTRA since 1968, and served as the EMP Graybeard Leader for DNA in the late 1990s. In 1984 he founded Metatech Corporation, which performs research for government agencies and private companies throughout the world. During his career, he has published over 375 reports and papers dealing with electromagnetic environments, effects, and protection. His current research interests are the effects of intense EM fields on commercial electronic systems. He is the Chairman of the IEEE EMC Society Technical Committee 5 on High Power Electromagnetics, and he is very active in the field of EMC standardization, chairing the IEC Technical Subcommittee 77C (High Power Transient Phenomena). He received the Lord Kelvin Award from the IEC in 2004 for outstanding contributions to international standardization. Dr. Radasky is an EMP Fellow, a Senior Member of the IEEE, and a registered professional electrical engineer in the State of California.