



7th Latin American IEEE Student Robotics Competition

Joint with JRI'2008 (The Brazilian Intelligent Robotic Journey) and
SBIA 2008 (19th Brazilian Symposium on Artificial Intelligence)

RULES FOR THE OPEN COMPETITION Version 1.5

Robots for Bombs Detection and Disarmament

1. Introduction

Few decades ago, the robots were presented only in scientific fiction or in human imagination. At the beginning of the sixties, the first robots were constructed and used to substitute the man at tasks involving disagreeable conditions such as high heating levels, noise or toxic gas presence while others were used at operations demanding extreme physical effort or repetitive works. Actually, the high technological advances stimulated the evolution of automation in such a way that the robots are now used at a variety of activities.

The use of bombs and explosives at wars, terrorism actions and by criminals in many scenarios require a person to come close to a potential explosive device before accurate detection and verification take place. The development of sophisticated robots for explosives detection capabilities and your use at this situation will keep personnel out of danger zone.

In this context, these rules propose a student autonomous robotic competition simulating the problem of bomb detection and disarmament.

2. Navigation Environment

The more recently developed high technology robots are capable to navigate virtually any terrain. For simulating slopes and mountains, the arena terrain was designed with elevations like illustrated at Figures 1 e 2.

The arena for competition will be constructed using MDF (Medium Density Fiberboard) with white opaque color. Black lines limit the start points. The arena presents two possible points of start and one elevation at the corner of the environment competition. The autonomous robots have to navigate and found the bombs randomly distributed in the environment and to disarm them at a minimum time. The first bomb (Bomb1) will be always allocated above the elevation. The second bomb (Bomb2) will be allocated randomly at one of the six regions defined, as it can be seen in Figure 3.

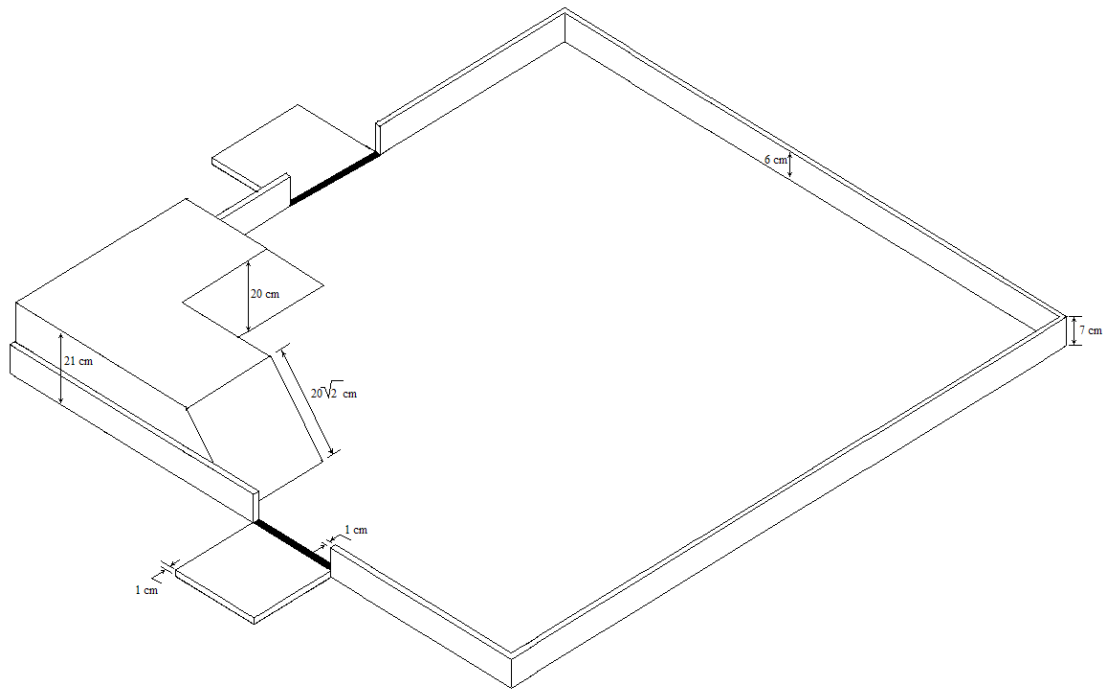

Figure 1. Environment for Open Robotic Competition

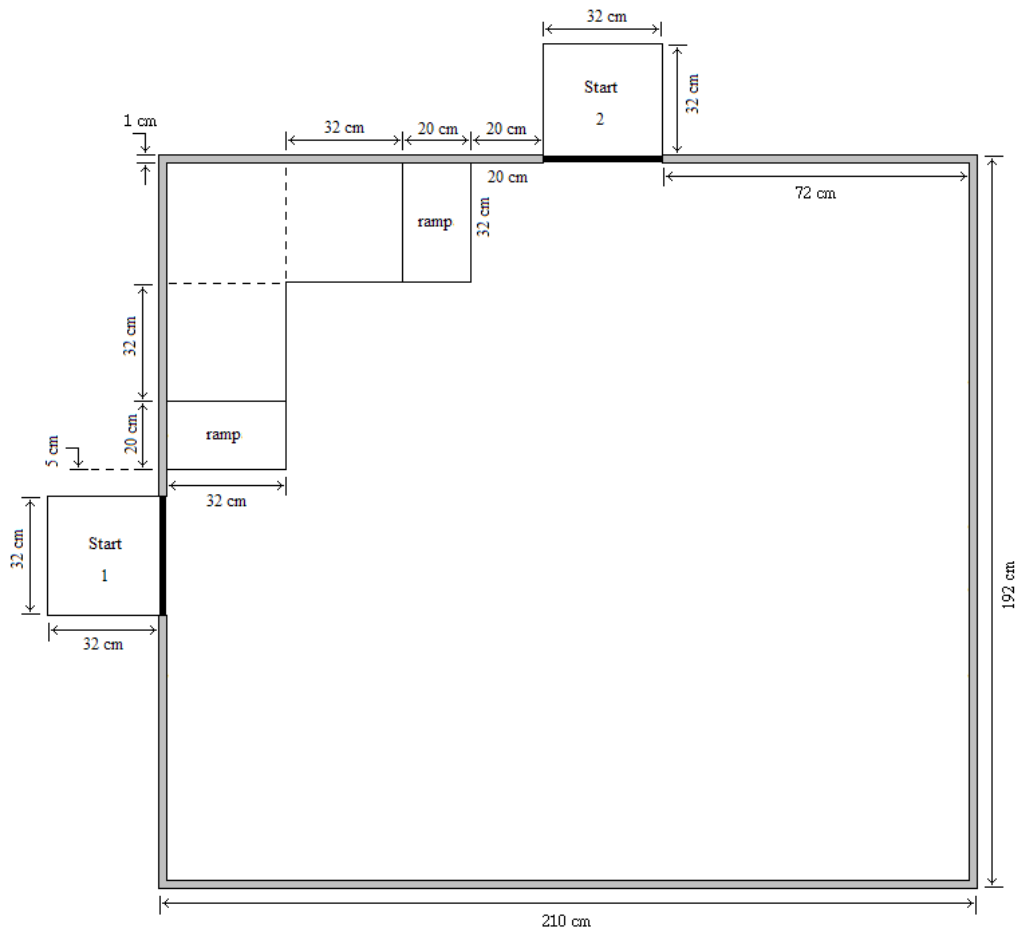

Figure 2. Superior View of Environment for Open Robotic Competition

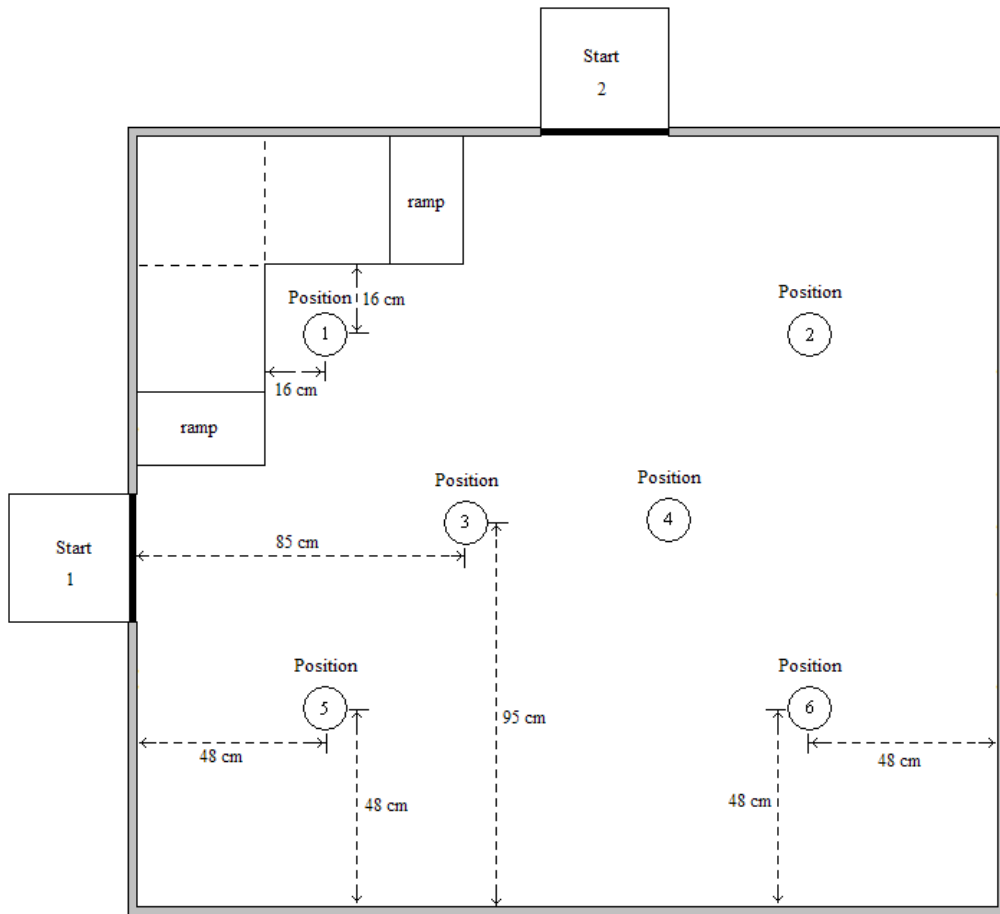

Figure 3. Positions to location Bomb2

3. The Bombs

To simulate the bombs, dry wood blocks with 10 cm x 10 cm x 10 cm will be made. Either bomb must be positioned above a white wood base of 10 cm x 10 cm x 5 cm.

The Bomb1, illustrated in Figure 4(a), will be colored in blue. One of the sides of the Bomb1 will present two wires and an adjacent side will have one wire. The wires colors are red, green and black. During the competition the Bomb1 will be always allocated, joint with its base, above the elevation. Note the wires will be always overturned to the elevation ramps, such as illustrated in Figure 4(b).

The Bomb2, illustrated in Figure 4(c), will be colored in yellow. At the same side of the bomb we will have one red wire, one green wire and one black wire. The lateral position of the Bomb2 at one of the six regions and joint with its base is random.

All the wires will have approximately 4 mm diameter with internal cable with approximately 1 mm diameter (18 AWG). The length of wires is 9 cm.

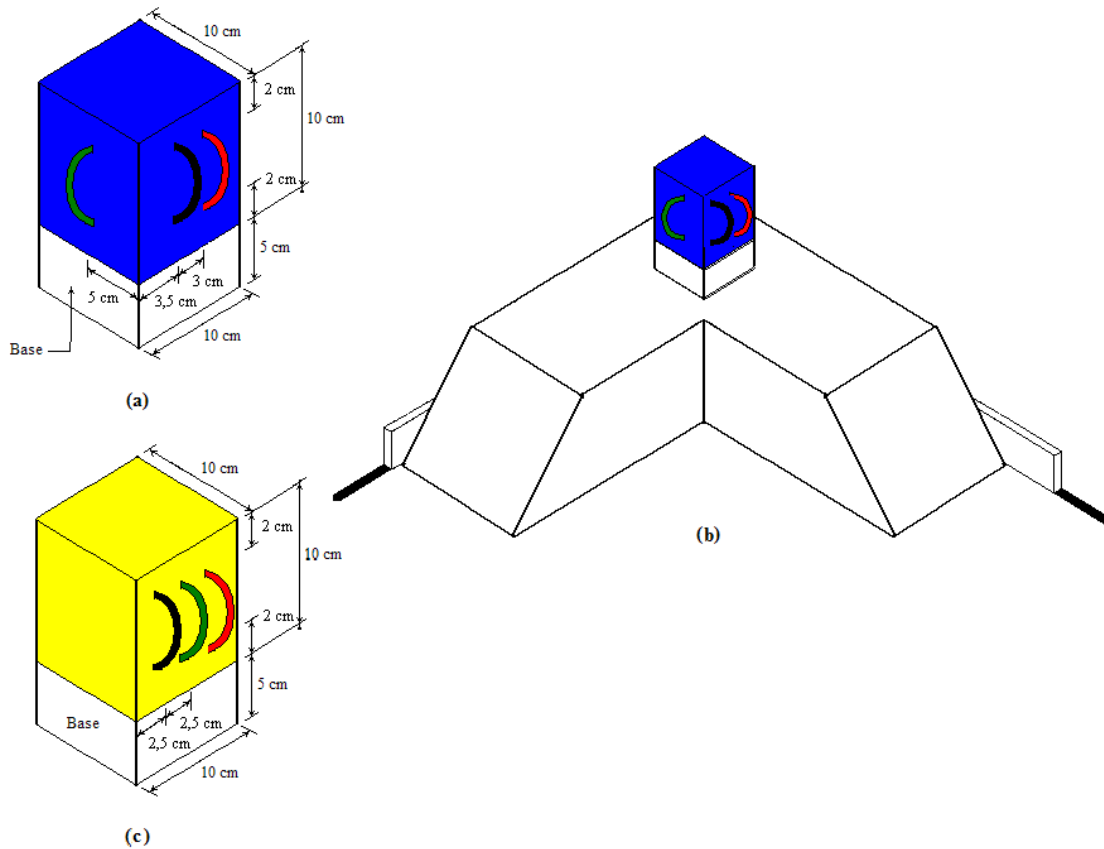

Figure 4. (a) Bomb1 above the base; (b) Bomb1, joint with its base, above the elevation; (c) Bomb2 above the base

4. The Robot

The robot must be designed and constructed, starting from zero, by the students of the team. It can be used any electronics and mechanics components commercially available in the market (as gears, wheels, resistors, microcontrollers, motors, sensors, actuators, etc), as well as any software functions can be designed. The maximum dimensions of robots are 30 cm x 30 cm x 30 cm. The robots can contain conveyors, cranes, camera, articulated arms or any mechanical structure, but the maximum body size may not be exceeded before the robot is turned on.

The robot must be fully autonomous and must work alone without anyone's cooperation.

When the robot finds a bomb it will have to disarm, simply pulling out the wire. For that, the robot can not use cutting objects, fire or anyone danger devices. The robot must first pull the red wire and then the green wire, without pulling the black wire. Nevertheless, at no time the bomb can be lifted or pulled down to the arena floor, otherwise the bomb explodes. The bomb also explodes if the robot pulls the wrong wire.

When the bomb explodes, the robot receives a punishment. In this case, the bombs must be repositioned at original positions and the robot must return to start point, while the counting time continues ticking. Only three punishments are possible at each round of the competition.

4. The Competition and Scores

The competition is composed of three rounds.

The winner robot will be the one that detects and disarms the two bombs at the minimum time independently of punishments, if they occurred, and independently of the round when this occurred. This criterion has priority but if anyone robot disarmed two bombs the criterion will be different as presented below.

If any bomb or only one bomb was disarmed, the criterions for classification is the cumulative score, obtained summing out the points at each round, defined as following:

- for each bomb disarmed the team acquire 03 points;
- for each punishment suffered, the team lose all positive points acquired before and sum one negative point (-1) to the team score.

The maximum time of competition at each round is 10 minutes. The team must use all the time of competition except if:

- the robot disarm the two bombs;
- the team received three punishments;
- the robot disarmed one bomb and stopped (according to team strategy or not) or locked, without movements, during at minimum one minute. In this case the team can choose to finalize the robot presentation holding the acquired score or to reposition the robot and bombs at original positions, receiving a punishment;
- the team that gives up a round, so receives the minimum score (-3 points).

Judges are responsible for ensuring the fulfillment of all competition rules. The order of presentation for each team is programmed previously by raffle. At each round the following steps will be commanded:

- the judge define the wire positions in each bomb; after this step the team can not perform any modification at software or re-program the robot;
- the start point is defined by raffle (for example, using a coin – heads or tails);
- the Bomb2 position will be defined by raffle (for example, playing a die);
- the chronometer is started; after this instant, mechanical or structural repair can be made only if the robot stops or locks, without movements, at least for one minute; in this case, the team must reposition the robot and bombs at original positions, receiving a punishment;
- any actions performed by the robot after the round has finalized will not be considered for matter of score assignment.

5. Final Considerations

The purpose of the proposed competition is to stimulate the development of robots that can work in bomb detection and disarmament scenario. Certainly the real terrorism problem and the typical trait of the bombs as well as the robots developed to disarm them are actually very different from those proposed in this rules. However, the main motivation for this competition is to stimulate the interest of robotics and artificial intelligence and to provide the development of researches and technologies that can be used in solutions that solve many problems at industry or at society in the real world.