

EMI Issues in Modern Power Electronic Systems

*Firuz Zare, Queensland University of Technology,
Brisbane, QLD, Australia, Email: f.zare@qut.edu.au*

Abstract—Electromagnetic compatibility of power electronic systems becomes an engineering discipline and it should be considered at the beginning stage of a design. Thus, a power electronics design becomes more complex and challenging and it requires a good communication between EMI and Power electronics experts. Three major issues in designing a power electronic system are Losses, EMI and Harmonics. These issues affect system cost, size, efficiency and quality and it is a trade-off between these factors when we design a power converter.

1. Introduction

Power Electronics is Power Processing. It is an application of electronic circuits to control a power converter in order to provide adjustable DC or AC voltage for different loads.

Power Electronics can be split into a Power and an Electronic circuit. The power circuit converts an unregulated input power from AC or DC type to a regulated AC or DC voltage or current and delivers it to a load. The electronic circuit controls the converter by measuring the input and output voltages and/or currents and generates signals for the power circuit. In a power electronic system, the flow of electric energy is controlled based on a load demand. In a power electronic system, line and EMI filters are important sections of a system. There are different load and utility requirements which should be fulfilled to reduce noise and harmonic levels of the system. Fig. 1 shows a block diagram of a power electronic system.

Main aims in modern power electronic systems are to deliver the power with maximum efficiency, minimum cost and weight in an integrated circuit. Power electronics has a significant role in different industries when power processing is required such as in computers, telecommunications, motor drives, cars and alternative energy systems.

In general, circuit elements in most electrical systems are resistors, capacitors, magnetic elements and transistors as shown in Fig. 2. Some of these components may be used in low or high power systems.

In most electronic circuits in which efficiency is not a main concern, circuit elements consist of resistors, capacitors and transistors. It is difficult to include magnetic elements into integrated circuits as they are large in size compared to capacitors and resistors. The transistors may operate in linear or switched mode as they transfer low power signals.

In power converters, efficiency is a main concern. Power circuits consist of capacitors, magnetic elements and transistors in switched mode. Resistors and power switches in linear mode are not used in most power circuits due to significant losses generated by current through these components which decrease the efficiency and cause thermal problems.

In power electronics high voltages and high currents are processed by fast switching to reduce losses which are significant sources of electromagnetic noise and it cause additional costs. Main EMI research targets in power electronics are:

- Analysis of electromagnetic emissions by measurements, modelling and simulations

- Development active EMI filters in high power converters to suppress EMI noise

Integration of power and electronic circuits is the market demand which intensifies the challenges. Advances in semiconductor technology brought fast power switches in the market to increase efficiency and power density of systems. This progress has helped power electronics engineers to improve system efficiency and performance but on the other hand it comes along with more need to comply with EMC requirements. As the electromagnetic compatibility of power electronic systems becomes an engineering discipline it should be considered at the beginning stage of a design. Thus, a power electronics design becomes more complex and challenging and it requires a good communication between EMI and Power electronics experts.

2. Power Switches

A modern power electronic system is a power processing system based on Pulse Width Modulation (PWM) technique. In a control system, a desired PWM signal is synthesized and transferred to power switches through gate drives to generate the same waveform at different voltage or current level. Thus, the power switches chop high voltages and/or currents when they are turned on and off.

When we consider a power switch as an ideal switch, that means the switch can handle unlimited current and blocks unlimited voltage. The voltage drop across the switch and the leakage current through the switch are considered zero with no rise and fall times as shown in Fig. 3. This assumption helps us to analyze a power circuit at low frequency but for practical considerations we should consider real power switches with three main issues, **Losses**, **Electromagnetic Interferences (EMI)** and **Harmonics!**

In real case, ideal switches do not exist. During switching transients, there are significant switching losses associated with dv/dt and di/dt . These phenomena depend on several issues such characteristics of power switches, control signals, gate drives, stray parameters and operating points of the system.

3. Losses

There are different types of losses in a power converter such as:

- Conduction and switching losses in power switches
- Losses due to charging and discharging stray components in a power converter
- Losses in a controller

When a switch is turned on or off, energy is lost during the switching transients as the operating point of the switch is changed from on (off) to off (on) state through an active state. This type of energy loss is called switching loss of the power switch and it depends on voltage across the switch, current through the switch and the switching time.

When a switch is off, normally a leakage current through the switch is very small and we ignore the energy loss associated with the off-state. But when the switch is on, the energy loss depends on current through the switch and a forward voltage of the switch. This type of energy loss is called conduction loss of the switch.

The average power loss in a switch over one switching cycle is given by the following equation which consists of the conduction and switching losses:

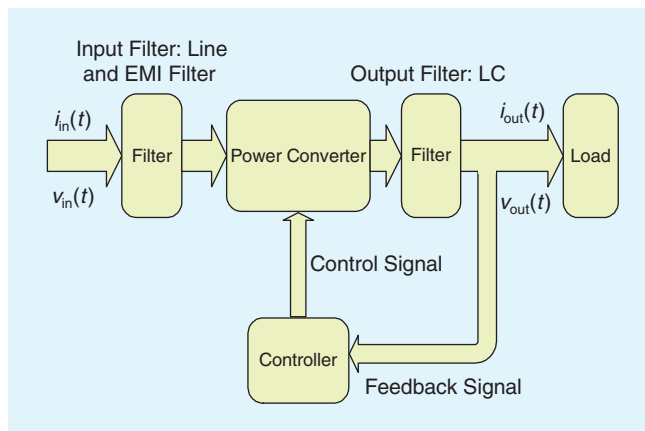

Fig. 1. A block diagram of a power electronic system.

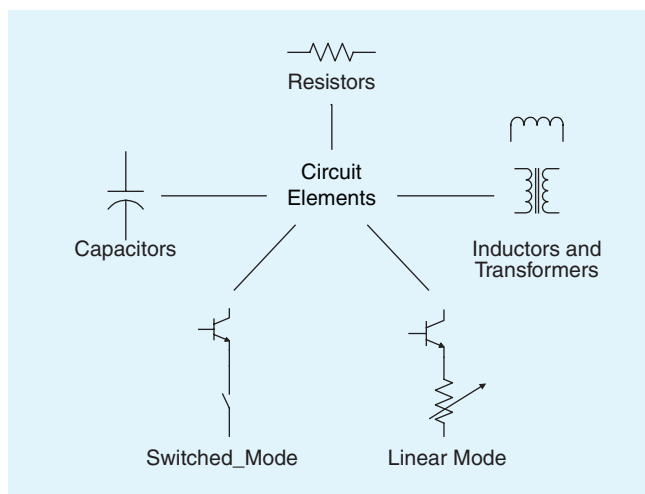

Fig. 2. Circuit elements in electrical systems.

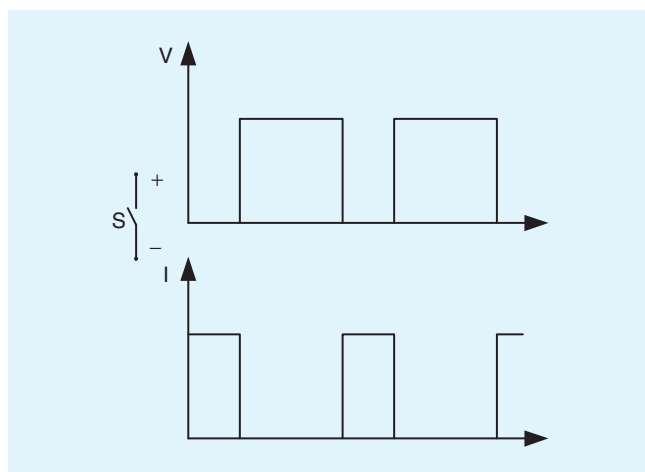

Fig. 3. Voltage and current waveforms in an ideal switch.

$$\bar{P}_s = \frac{1}{T_{sw}} \int_0^{T_{sw}} i_s v_s dt = \bar{P}_{cond} + \bar{P}_{sw}$$

Assuming that the on and off switching times are small compared to switching cycle, T_{sw} and the leakage current is negligible, $I_{off} = 0$. Thus the conduction loss is given by:

$$\bar{P}_{cond} = V_{on} \times I_{on} \times D$$

$$D = \frac{t_{on}}{T_{sw}}$$

Where t_{on} is the time when the switch is in on-state, V_{on} is a voltage drop across the switch, I_{on} is a current through the switch assuming it is constant in magnitude and D is a duty cycle.

The switching loss should be calculated based on instantaneous current and voltage waveforms.

$$\bar{P}_{sw} = f_{sw} \left(\int_{t_1}^{t_1+t_{sw_on}} i_s v_s dt + \int_{t_2}^{t_2+t_{sw_off}} i_s v_s dt \right)$$

Where, t_1 and t_2 are the times when gate signals are applied to turn on and off the switch, respectively; t_{sw_on} and t_{sw_off} are

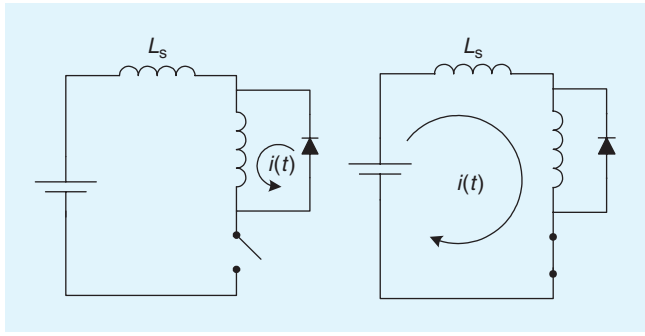

Fig. 4. Stray inductance of a current loop and transient effect.

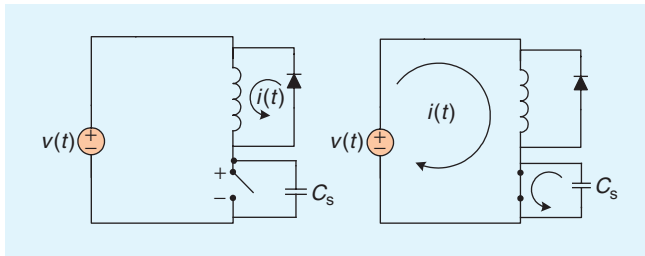

Fig. 5. Stray capacitance in a power converter and transient effect.

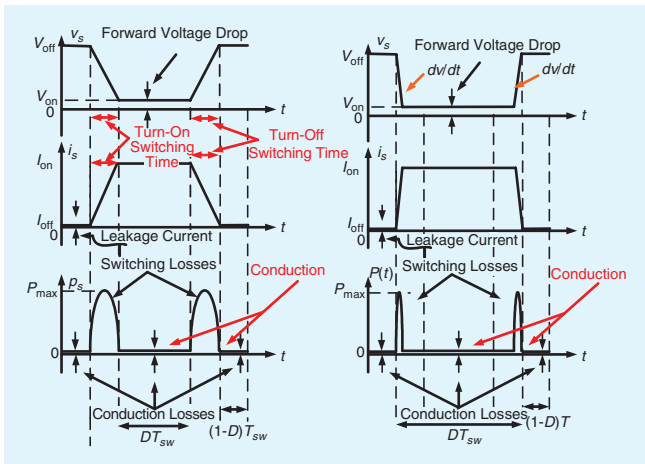

Fig. 6. Voltage, current and power waveforms of a switch at two different switching times.

turn-on and turn-off switching times. This equation shows that the switching loss is proportional to the switching frequency. Thus increasing the switching frequency increases the switching losses!

In all power electronic systems, there are stray inductances and capacitances due to interconnections between the power components via wire, conductor plates or any other types of conductors. In a power electronic circuit when a power switch is turned on and off, stray inductance associated with a current loop is charged and discharged as shown in Fig.4. The energy stored in the inductor depends on the current magnitude and inductance value. Every time when the switch is turned on and off, energy is lost through this inductor which affects the total energy loss and efficiency. It may also create significant over voltage during switching transitions due to high rate of current change.

$$E_{L_s} = \frac{L_s \times i^2}{2}$$

$$V_{over} = L_s \times \frac{di}{dt}$$

Due to capacitive couplings in power converters we may charge and discharge these capacitors when power switches are switched on and off as shown in Fig.5. The energy stored in the capacitor depends on the voltage magnitude and capacitance value. It may also create significant pulse current when the switch is turned on and the capacitor is discharged through the switch.

$$E_{C_s} = \frac{C_s \times v^2}{2}$$

$$i_{leakage} = C_s \times \frac{dv}{dt}$$

In a power electronic system, there are other circuits such as gate drives, controllers, sensors and passive filters which consume power. The total losses in a power electronic system is the sum of all losses and the efficiency of a system can be calculated based on input power and total losses as given below:

$$\eta = \frac{\bar{P}_{out}}{\bar{P}_{in}} = \frac{\bar{P}_{in} - \bar{P}_{loss}}{\bar{P}_{in}} = 1 - \frac{\bar{P}_{loss}}{\bar{P}_{in}}$$

Why do we need to reduce losses?

In a power converter, increasing losses decreases the efficiency of the system and increases junction temperature of power switches which may damage them if heat is not transferred to ambient. Thus, the system may need a heat sink to transfer heat from junction into ambient which increases cost, size and weight of the power converter.

A main part of total losses is the switching loss which depends on switching times and switching frequency. Fig.6 shows two waveforms with different switching times. The switching loss can be reduced by decreasing the switching time, but fast switching increases dv/dt and di/dt which affects EMI noise!

According to the above equations, decreasing the switching frequency reduces the losses but increases voltage and current ripples. To improve the quality of the output voltage, we may need a better filter with large capacitor and inductor which increases the cost and weight of the system!

4. EMI

Two major sources of EMI in power electronics are dv/dt and di/dt during switching times. In fact, a DC voltage of few hundred volts is chopped by a power switch in a fraction of microsecond. Thus, conducted emission is a major issue in most power electronic systems due to significant over voltage and leakage current generated by fast switching and stray components of the system.

- High di/dt may create significant over voltage in power converters due to stray inductance of current loops
- High dv/dt may create significant leakage current in magnetic elements and electric motors due to stray capacitive coupling between windings and a frame

How to reduce EMI noise?

As discussed in the above section, decreasing dv/dt and di/dt means increasing the switching time which increases losses. Thus, it is a trade off between losses and EMI to determine the switching time. The other alternative is to reduce stray inductance and capacitance of a power electronic system using a better layout, interconnection and configuration.

5. Harmonics

In power processing, an input voltage/current is chopped based on a PWM control signal which generates a desired output voltage and/or current waveform. The output voltage and/or current have harmonics around switching frequency and these harmonics are reduced by a low pass filter.

In power converters, switching frequency and passive filters have a significant role in reducing the harmonic magnitude on both input and output sides.

Fig.7 shows voltage and current waveforms of an inductor at two different switching frequencies and it is obvious that increasing the switching frequency decreases the output ripple magnitude but a main drawback is more switching losses. In some DC-DC converters, a switching frequency of 75 kHz or more is used to increase power density and reduce low pass filter size but it has a significant impact on EMI as the second side band of the harmonic contents will be at the frequency of 150 kHz or above. There are some new PWM techniques to spread the spectral content of the signal such as Random PWM technique with variable switching or pulse position.

How to reduce harmonics?

Increasing switching frequency can reduce low order harmonics and improve quality of output voltage or for a same quality, it reduces the size of low pass filter (L&C components); but the switching losses are increased. Thus it is a trade off between quality and losses.

Who designs a power converter?

How consultation with an EMI expert can help at the first stage of a design?

From the previous discussion, we have found that there are relationships between the three main factors, Losses, EMI and Harmonics. Two main parameters which can affect these three factors are harmonics and switching time as shown in Fig.8. If a switching cycle is much bigger than a transient time, the effect of dv/dt and di/dt on harmonic contents is negligible except at very high switching frequencies.

It is very challenging to determine switching frequency and switching time of power switches which requires breath

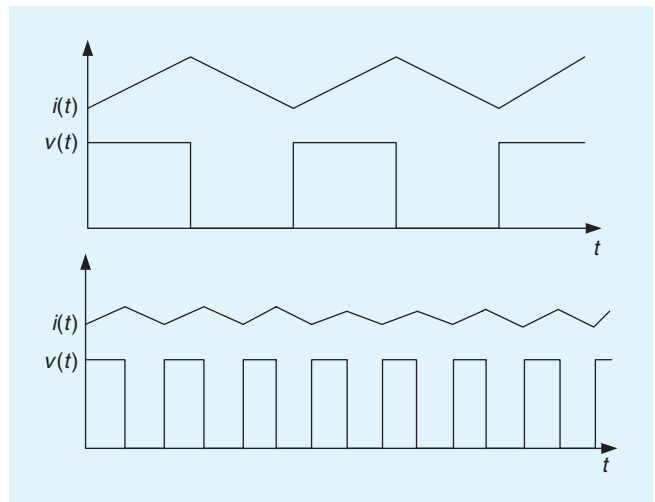

Fig. 7. Voltage and current waveforms at two different switching frequencies.

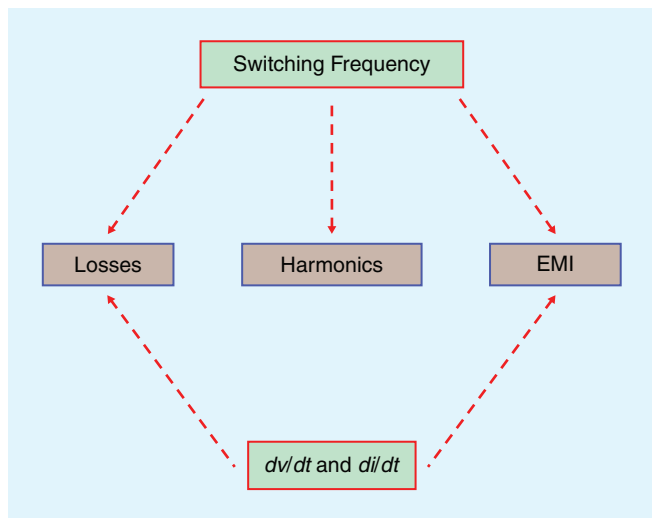

Fig. 8. A relationship between Losses, EMI and Harmonics.

and depth knowledge of EMC and Power Electronics in order to optimise a system at the beginning stage the design.

It is obvious that a good layout for a power converter can reduce parasitic components which reduce losses and EMI noise. Switching frequency and PWM modulation should be determined based on:

- Ripple magnitude on output voltage
- Total losses, ambient temperature and thermal resistance between power switches and ambient
- Size and cost of passive filter

Switching time can be chosen considering:

- Switching losses
- Maximum dv/dt and di/dt values of power switches
- Over voltage and leakage current magnitudes which affect EMI filter size and cost

6. Conclusions

In modern power converters, achieving high efficiency is a main concern and a key factor to save energy but it is very challenging task as we need to compromise with key factors such as quality and power density. It is apparent that increasing the switching

speed and decreasing the switching frequency decrease the switching losses but main drawbacks are increasing EMI noise and reducing quality of power converters due to high dv/dt & di/dt and high ripple on output voltage or current, respectively.

The main challenges in designing a modern power electronic system are to:

- Understand the EMI issues in power converters
- Analyze switching transient in a power converter
- Consider EMI at the beginning stage of design and compromise it with losses and low order harmonics
- Select a proper topology and PWM technique
- Design good magnetic elements such as inductors, transformers and electric machines with low capacitive couplings
- Design a good layout for power circuits with low stray inductances

Reference

[1] F. Zare, *Power electronics e-book* [Online]. Available: www.peeeb.com; from this website, you can virtually attend lectures and tutorials and also access to lecture notes and computer labs. ISBN 978-0-646-49442-5, 2008.

Biography

Dr. Firuz Zare received his B.Eng degree in Electronic Engineering from Gilan University, his MSc degree in Power Engineering from K.N Toosi University and his Ph.D. degree in



Dr. Firuz Zare

Power Electronics from Queensland University of Technology in 1989, 1995 and 2001, respectively. He spent several years in industry as a team leader and development engineer where he was involved in electronics and power electronics projects. Dr. Zare won a student paper prize at the Australian Universities Power Engineering Conference (AUPEC) conference in 2001 and was awarded a Symposium Fellowship by the Australian Academy of Technological Science and Engineering in 2001. He received the Vice Chancellor's research award in 2009 and faculty excellence award in research as an early career academic from Queensland University of Technology in 2007. Dr. Zare has published over 70 journal and conference papers and technical reports in the area of Power Electronics. He has been invited as a reviewer and technical chair of national and international conferences and presented several seminars and workshops. He presented a half-day tutorial at the 2007 IEEE International Symposium on EMC in Hawaii, at the EMC Asia Pacific Workshop in Singapore in May 2008 and at the 2008 IEEE International Symposium on EMC in Michigan. Dr. Zare is a senior lecturer at the Queensland University of Technology, Australia and a senior member of the IEEE. **EMC**