

GES is pleased to have been selected the official service contractor by the Show Organizer to design and produce your show. Our goal is to ensure your show participation is a success.

GES is involved in many areas relative to the show and if at any time during the planning process you are unsure where to turn, just ask us, we are at your service.

Please ensure that you review this section carefully as it contains information, **DISCOUNT PRICES** and order forms for each of the many services being provided by **GES**.

For your convenience, we will be offering the following services:

- ✓ **Furnishings**
- ✓ **Electrical**
- ✓ **GEM Exhibits & Accessories**
- ✓ **Installation & Dismantling Labour**
- ✓ **Material Handling - Advance & Direct**

To take advantage of our **DISCOUNT PRICING**, all order forms and full payment must be received on or before the Discount Date of March 5, 2012 as indicated on each form. **GES** accepts Visa, Mastercard, American Express, Cheques and Cash as methods of payment for our services. All exhibitors are responsible for payment of G.S.T. when exhibiting in Alberta.

If you need assistance or additional information contact our **Exhibitor Services Department at (780) 469-7767**.

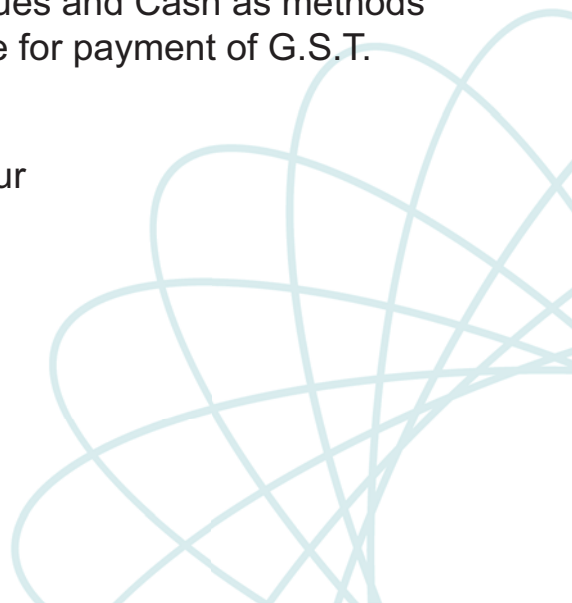

Introductory Letter

Dear Exhibitor,

We are pleased that GES has been selected as your Official Service Contractor for the:

IEEE ESTMP TRADE SHOW

Please review this manual carefully. It contains information and order forms for each of the many services offered by GES. If we are to serve you efficiently, it is most important that you return these forms to us promptly.

Please find below a list of the display items that are included in each standard booth:

Each standard booth is: 10' x 10' and includes:

- *8' High Back Wall Drape*
- *3' High Side Wall Drape*

By placing your orders in advance, you can save up to 40% on most decorating items. Advance orders also make for a smoother, more efficient move-in avoiding unnecessary waits, the possibility of selecting a sold out item and showsite delivery delays.

To qualify for discount prices, orders must be received in our office on or before the deadline date on the order forms. Please be sure to reference each order form as deadline dates may vary.

GES requires payment in full at the time services are ordered. For your convenience, we require that you provide a credit card authorization with your initial order. This may be used to charge labour and material handling services not covered in your advance order. We accept Visa, Mastercard, & American Express, as well as cheques.

We realize that exhibiting in a tradeshow can be complicated. If you need assistance with your orders or additional information, please call our offices at 877-505-7767 and ask to speak to an Exhibitor Service Executive (ESE).

In addition, our GES Servicentre staff will be available throughout the show to assist you.

Thank you in advance for your valued business. We look forward to serving you and wish you a most successful event.



IEEE ESTMP TRADE SHOW

E12-1A

March 19 - 20, 2012
Mayfield Trade Centre

DEADLINE DATE:
March 5, 2012

Payment & Credit Card Charge Authorization

7730 - 34th Street NW, Edmonton, AB T6B 3J6 Phone: 877.505.7767 Fax: 877.469.1619 www.gesexpo.ca edmonton@ges.com

COMPANY NAME	EMAIL ADDRESS		BOOTH #
STREET	CITY	PROVINCE	POSTAL CODE
PHONE	FAX	P.O. #	
SHOWSITE CONTACT	SHOWSITE CONTACT EMERGENCY #		

Payment Policy

Payment for Services - GES requires payment in full at the time services are ordered. Further, GES requires that you provide a credit card authorization with your initial order. For your convenience, we will use this authorization to charge your account for services, which may include labour and material handling, not covered by your initial payment. All applicable taxes will be added and charged to your credit card.

Discount Pricing - To qualify for discount pricing, orders must be received with payment on or before the discount price deadline.

Method of Payment - GES accepts American Express, Mastercard, Visa, cheque and wire transfers. Purchase orders are not considered payment. Exhibitors will be charged a \$25.00 fee for NSF cheques.

Third Part Billing - Each exhibiting firm is ultimately responsible for all charges incurred on its behalf. GES reserves the right to institute collection action against the exhibitor if the authorized third party does not pay.

Tax Exempt - If you are tax exempt in Canada you must provide a GST Exemption Certificate. Please send the above information to the GES office for this show. Taxes vary by location and will be added to your invoice, if you do not submit your tax exempt certificate prior to the deadline.

Adjustments & Cancellations - No adjustments will be made to invoices after the close of the show. Please refer to the individual forms for cancellation fees. All orders cancelled by the Exhibitor or due to the cancellation of an event or their non-participation may be subject to cancellation fees equal to 50% - 100% of the total order based upon the status of move-in, work performed, and/or GES set up costs or expenses. A minimum non-refundable deposit of \$25.00 will be applied toward the invoice, unless there is a cancellation of your order.

If you have any questions regarding our payment policy please call GES at 877.505.7767 or visit the GES Servicentre at the show.

Please complete the information and return payment in full with this form and your orders. You may choose to pay by credit card, cheque or wire transfer, however, we require your credit card charge authorization to be on file with GES.

You agree to late fees of up to 1.5% per month on any balance not paid at the conclusion of the event or balance left without appropriate credit card on file.

For your convenience, we will use this authorization to charge your credit card for any additional amounts ordered by your representative or services rendered to your company for this event.

Bank wire transfer information:

GES CANADA Exposition Services Ltd.
Canadian Imperial Bank of Commerce, 939 Lawrence Avenue E.
North York, Ontario, Canada, M2C 1P9
Canadian Dollars: Account # 73-07616 Transit # 00132 Swift Code: CIBCCATT
Routing/BIC/NCC/BSC or ABA # 026009593
American Dollars: Account # 0267015 Transit # 00132 Swift Code: CIBCCATT
Routing/BIC/NCC/BSC or ABA # 026009593
To properly credit your account, send the following information to the GES CANADA address listed on the order forms: exhibiting company name, show name and the booth # date and amount of the transfer bank and country where transfer originated.

I agree in placing this order that I have accepted GES payment policy and GES Terms & Conditions of Contract

PLEASE

AUTHORIZED SIGNATURE

AUTHORIZED NAME - PLEASE PRINT

DATE

Credit Card Charge Authorization

(All Information Must Be Provided)

PROVIDE EXPIRATION DATE

EXPIRATION DATE

MasterCard

VISA

American Express

Account #

CARDHOLDER'S NAME

PLEASE PRINT

CARDHOLDER'S BILLING ADDRESS

CITY

PROVINCE / STATE

POSTAL CODE

PLEASE

CARDHOLDER'S SIGNATURE

DATE

Calculation of Orders

Furnishings	\$
Specialty Furnishings	\$
Carpet	\$
Cleaning	\$
Graphics & Signage	\$
Plants & Greenery	\$
Exhibit System Rentals (GEM)	\$
GEM Accessories	\$
GEM Show Special	\$
Installation & Dismantling Labour	\$
In-Booth Forklift	\$
Material Handling	\$
Electrical Services	\$
Wire Transfer Fee - Add \$10.00	\$
FULL PAYMENT DUE:	\$

To simplify payment, send a cheque payable to GES CANADA for your entire order or note the amount to be charged to your credit card.

Charge my credit card in the amount of: \$

Enclosed is a cheque in the amount of: \$

All orders are governed by the GES Payment Policy and GES CANADA Terms & Conditions of Contract as specified in this Exhibitor Kit.

furnishings



Grey Fabric Side Chair



Grey Fabric Counter Stool



Grey Fabric Arm Chair



Grey Lounge Chair



Steno Chair



30" Round / 30" High Pedestal Table



30" Round / 18" High Coffee Table



4', 6', OR 8' Long Raised Draped Table with White Vinyl Top



4', 6', OR 8' Long Draped Table with White Vinyl Top



furnishings



Coat Tree



22" X 28"
Chrome Sign Holder
(sign extra)



Easel



Gold Ballot Drum



Plexi Pocket



40" w x 20" d x 36" h
White Counter Storage Unit



Bag Holder 41"H



Stanchions



Plastic
Wastebasket



Furniture & Accessories Order Form

7730 - 34th Street NW, Edmonton, AB T6B 3J6 Phone: 877.505.7767 Fax: 877.469.1619 www.gesexpo.ca edmonton@ges.com

PRICE LIST

Quantity	Item #	Description	Discount \$	Regular \$	Total Price
Skirted Tables					
<i>Skirting for Tables - White Vinyl Top and Pleated Skirt on 3 Sides, Choose Colour:</i>					
	24 (DT4)	Skirted 4' Table, Skirted 4 Sides	\$ 75.00	\$ 105.00	\$
	26 (DT6)	Skirted 6' Table	\$ 82.00	\$ 115.00	\$
	28 (DT8)	Skirted 8' Table	\$ 89.00	\$ 125.00	\$
	(DMS)	4th Side Skirted, Optional	\$	31.00	\$
Skirted Raised Tables					
<i>Skirting for Raised Tables - White Vinyl Top & Pleated Skirt on 3 Sides, Choose Colour:</i>					
	24H (RD4)	Skirted 4' Raised Table, Skirted 4 Sides	\$ 83.00	\$ 116.00	\$
	26H (RD6)	Skirted 6' Raised Table	\$ 103.00	\$ 144.00	\$
	28H (RD8)	Skirted 8' Raised Table	\$ 126.00	\$ 176.00	\$
	(DMS)	4th Side Skirted, Optional	\$	31.00	\$
Unskirted Tables					
	(UD4/6/8)	Unskirted Table (30" high) <input type="checkbox"/> 4' <input type="checkbox"/> 6' <input type="checkbox"/> 8'	\$ 59.00	\$ 83.00	\$
	(RUD4/6/8)	Unskirted Raised Table (40" high) <input type="checkbox"/> 4' <input type="checkbox"/> 6' <input type="checkbox"/> 8'	\$ 96.00	\$ 134.00	\$
Tables					
	23 (FCOFT)	Round Coffee Table, 18" Tall	\$ 50.00	\$ 70.00	\$
	21 (FPEDT)	Round Pedestal Table, 30" Tall	\$ 64.00	\$ 90.00	\$
	(FPEDT)	Round Cocktail Table, 40" Tall	\$ 78.00	\$ 109.00	\$
Chairs					
	12 (FFC)	Plastic Folding Chair	\$ 23.00	\$ 32.00	\$
	14 (FGFAC)	Arm Chair, Padded Grey	\$ 36.00	\$ 50.00	\$
	16 (FGFCS)	Counter Stool, Padded Grey	\$ 75.00	\$ 105.00	\$
	17 (FGFSC)	Side Chair, Padded Grey	\$ 35.00	\$ 49.00	\$
Display Accessories					
	55 (FCSH)	Signholder	\$ 42.00	\$ 59.00	\$
	70 (FESL)	Easel	\$ 35.00	\$ 49.00	\$
	58 (FTS)	Tape Stanchion	\$ 35.00	\$ 49.00	\$
	60 (FGR)	Garment Rack on Wheels	\$ 40.00	\$ 56.00	\$
	(FBF)	Refrigerator, 4.5 cu.ft.	\$ 171.00	\$ 239.00	\$
	(FSBD)	Ballot Drum, Table Size	\$ 62.00	\$ 87.00	\$
	(FBH)	Bag Stand	\$ 59.00	\$ 83.00	\$
	56 (FWB)	Wastebasket	\$ 20.00	\$ 28.00	\$
	(DU)	Upright, 8' (with base)	\$ 17.00	\$ 24.00	\$
	(DCB)	Telescoping Crossbar	\$ 13.00	\$ 18.00	\$
Custom Booth Drape					
<i>8' Back Drape & 3' Side Drape, 4 feet minimum order</i>					
	10 (D3)	Linear feet of Side Drape per foot (3' High)	\$ 5.30	\$ 7.42	\$
	11 (D8)	Linear feet of Back Drape per foot (8' High)	\$ 5.75	\$ 8.05	\$
<i>Please include Booth Layout form for placement of items</i>					

Table/Raised Table Skirts/Drape Colours: Grey will be provided if no colour is indicated below: Black, Blue, Burgundy, Forest Green, Grey, Red, White.	TOTAL OF ALL ITEMS ORDERED:	\$
	5% GST:	\$
	PAYMENT ENCLOSED:	\$

All orders governed by the GES payment policy & GES Terms & Conditions of Contract as specified in this Exhibitor's Kit. Cancellation Policy: Items cancelled will be charged 50% of original price after move-in begins and 100% after installation.

COMPANY NAME	EMAIL ADDRESS	BOOTH#
AUTHORIZED SIGNATURE	AUTHORIZED CONTACT	DATE

All orders are governed by the GES CANADA Payment Policy and GES Terms & Conditions of Contract as specified in this Exhibitor Kit.

Specialty Furniture Order Form

7730 - 34th Street NW, Edmonton, AB T6B 3J6 Phone: 877.505.7767 Fax: 877.469.1619 www.gesexpo.ca edmonton@ges.com

PRICE LIST



Lounge Furniture

Quantity	Item #	Description	Discount \$	Regular \$	Total Price
	(EBLS3)	Leather Sofa - 3 Seater	\$ 214.00	\$ 300.00	\$
	(EBLS2)	Leather Sofa - 2 Seater	\$ 177.00	\$ 248.00	\$
	(EBLS1)	Leather Sofa Chair - 1 Seat	\$ 138.00	\$ 193.00	\$
	(ECTC3)	Coffee Table	\$ 61.00	\$ 85.00	\$
	(EETC3)	End Tables	\$ 41.00	\$ 57.00	\$



Specialty Furniture

Quantity	Item #	Description	Discount \$	Regular \$	Total Price
	41A (EFBS)	Fanback Stool	\$ 112.00	\$ 157.00	\$
	41B (FPEDT)	30" Bistro Table	\$ 127.00	\$ 178.00	\$
	42A (EBLBS)	Leather Bistro Stool	\$ 132.00	\$ 185.00	\$
	43A (EGFBS)	Fabric Bistro Stool	\$ 148.00	\$ 207.00	\$
	44A (EBLMC)	Leather Meeting Chair	\$ 91.00	\$ 127.00	\$
	44B (EBMT)	42" Meeting Table	\$ 133.00	\$ 186.00	\$
	45A (EGFC)	Leather High Back Meeting Chair	\$ 98.00	\$ 137.00	\$
	(EBLHC)	Leather High Back Rolling Chair	\$ 129.50	\$ 181.00	\$
	(FLR)	Literature Rack	\$ 89.00	\$ 125.00	\$

ONSITE ORDERS MAY NOT BE AVAILABLE FOR THIS EQUIPMENT

Notes:	TOTAL OF ALL ITEMS ORDERED:	\$
	5% GST:	\$
	PAYMENT ENCLOSED:	\$

All orders governed by the GES payment policy & GES Terms & Conditions of Contract as specified in this Exhibitor's Kit.

Cancellation Policy: Items cancelled will be charged 100% of original price after move-in begins.

COMPANY NAME	EMAIL ADDRESS	BOOTH #
AUTHORIZED SIGNATURE	AUTHORIZED CONTACT	DATE



IEEE ESTMP TRADE SHOW

March 19 - 20, 2012
Mayfield Trade Centre

E12-4

DEADLINE DATE:
March 5, 2012

Carpet Order Form

7730 - 34th Street NW, Edmonton, AB T6B 3J6 Phone: 877.505.7767 Fax: 877.469.1619 www.gesexpo.ca edmonton@ges.com

PRICE LIST

Quantity	Item #	Description	Discount \$	Regular \$	Total Price
----------	--------	-------------	-------------	------------	-------------

Standard Carpet

	C1010	10' x 10' 16 oz. Standard Booth Carpet	\$ 142.00	\$ 199.00	\$
	C1020	10' x 20' 16 oz. Standard Booth Carpet	\$ 284.00	\$ 398.00	\$
	C1030	10' x 30' 16 oz. Standard Booth Carpet	\$ 426.00	\$ 596.00	\$

Custom-Cut Carpet

<i>Custom-cut carpet is required for all booths larger than 30', or for booths configured as an island or peninsula. No Exceptions.</i>					
	CMISC	' X ' = _____ Sq.Ft.	\$ 1.42	\$ 1.99	\$
<i>Price include delivery, installation, rental, and removal.</i>					

Under Padding

	CACU	10' x 10' Under Padding	\$ 95.00	\$ 133.00	\$
	CACU	10' x 20' Under Padding	\$ 190.00	\$ 266.00	\$
	CACU	10' x 30' Under Padding	\$ 285.00	\$ 399.00	\$
	CACU	' X ' = _____ Sq.Ft.	\$ 0.95	\$ 1.33	\$

Plastic Covering For Protection

	CAPC	' X ' = _____ Sq.Ft.	\$ 0.20	\$ 0.26	\$
<i>Exhibitor is responsible for the removal of the plastic covering prior to show opening.</i>					

Carpet Packages

		10' x 10' Carpet Package	\$ 231.00	\$ 323.00	\$
		10' x 20' Carpet Package	\$ 462.00	\$ 647.00	\$
		10' x 30' Carpet Package	\$ 693.00	\$ 970.00	\$
		' X ' = _____ Sq.Ft.	\$ 2.31	\$ 3.15	\$
<i>Includes carpet, under pad, and plastic covering.</i>					

Please Indicate Choice

Carpet Colour:		Electrical Under Carpet?	
<input type="checkbox"/> Black	<input type="checkbox"/> Forest Green	<input type="checkbox"/> Yes	
<input type="checkbox"/> Blue	<input type="checkbox"/> Grey	<input type="checkbox"/> No	
<input type="checkbox"/> Burgundy	<input type="checkbox"/> Red		

Notes:	TOTAL OF ALL ITEMS ORDERED:	\$
	5% GST	\$
	PAYMENT ENCLOSED:	\$

All orders governed by the GES payment policy & GES Terms & Conditions of Contract as specified in this Exhibitor's Kit.
Cancellation Policy: Carpet cancelled will be charged 50% of original price after move-in and 100% of original price after installation.

COMPANY NAME	EMAIL ADDRESS	BOOTH #
AUTHORIZED SIGNATURE	AUTHORIZED CONTACT	DATE



IEEE ESTMP TRADE SHOW

March 19 - 20, 2012
Mayfield Trade Centre

E12-5

DEADLINE DATE:
March 5, 2012

Booth Cleaning Order Form

7730 - 34th Street NW, Edmonton, AB T6B 3J6 Phone: 877.505.7767 Fax: 877.469.1619 www.gesexpo.ca edmonton@ges.com

PRICE LIST

Quantity	Item #	Description	Discount \$	Regular \$	Total Price
----------	--------	-------------	-------------	------------	-------------

Initial Cleaning Service

<i>Service performed the evening prior to show opening. Carpets are vacuumed and waste baskets are emptied</i>					
	BCICB	10' x 10' Booth	\$ 35.00	\$ 48.00	\$
	BCICSF	10' x 20' Booth	\$ 70.00	\$ 96.00	\$
	BCICSF	10' x30' Booth	\$ 105.00	\$ 144.00	\$
	BCICSF	___ ' X ___ ' = _____ Sq.Ft.	\$ 0.35	\$ 0.48	\$

Daily Cleaning Service

<i>Service performed prior to show opening and each night at show close for duration of the show. Carpets are vacuumed and wastebaskets are emptied.</i>					
	BCDC100	10' x 10' Booth	\$ 50.00	\$ 69.00	\$
	BCDC100	10' x 20' Booth	\$ 100.00	\$ 138.00	\$
	BCDC100	10' x 30' Booth	\$ 150.00	\$ 207.00	\$
	BCDCSF	___ ' X ___ ' = _____ Sq.Ft. (Booths 400 - 1000 sq.ft.)	\$ 0.42	\$ 0.58	\$
	BCDCSF	___ ' X ___ ' = _____ Sq.Ft. (Booths 1000 sq.ft. or larger)	\$ 0.35	\$ 0.48	\$

Carpet Shampooing

<i>Service performed evening prior to show opening. GES cannot guarantee the complete removal of all stains due to the unknown nature of such stains.</i>					
	BCCSB	10' x 10' Booth	\$ 75.00	\$ 105.00	\$
	BCCSSF	10' x 15' Booth	\$ 112.50	\$ 157.50	\$
	BCCSSF	10' x 20' Booth	\$ 150.00	\$ 210.00	\$
	BCCSSF	___ ' X ___ ' = _____ Sq.Ft.	\$ 0.75	\$ 1.05	\$

Additional Services

<i>Porter service will be performed throughout the duration of the show, as often as the exhibitor requests. Arrangements must be made prior to the show. Service includes emptying of wastebaskets and general clean-up of booth.</i>					
	LRCR	Porter Service - During the hours of 8am - 5pm (per hour)	Call for Quotation	\$	
	LRSOT	Porter Service - All other times (per hour)	Call for Quotation	\$	

Notes:	TOTAL OF ALL ITEMS ORDERED:	\$
	5% GST	\$
	PAYMENT ENCLOSED:	\$

All orders governed by the GES payment policy & GES Terms & Conditions of Contract as specified in this Exhibitor's Kit.

COMPANY NAME _____ EMAIL ADDRESS _____ BOOTH # _____

AUTHORIZED SIGNATURE _____ AUTHORIZED CONTACT _____ DATE _____



Plants & Greenery Order Form

7730 - 34th Street NW, Edmonton, AB T6B 3J6 Phone: 877.505.7767 Fax: 877.469.1619 www.gesexpo.ca edmonton@ges.com

PRICE LIST

Quantity	Item #	Description	Discount \$	Regular \$	Total Price
----------	--------	-------------	-------------	------------	-------------

Green Floor Plants

	PFP25	2' to 5' Tall	\$ 55.00	\$ 77.00	\$
	PFP68	6' to 8' Tall	\$ 92.00	\$ 129.00	\$

Green Table Plants

	PBF	Boston Ferns	\$ 48.00	\$ 67.00	\$
	PTP	Table Plants - 10" Pot	\$ 44.00	\$ 62.00	\$
	PHB	Hanging Basket	\$ 42.00	\$ 59.00	\$

Flowering Plants & Special Requests

	PMUM	Mums	\$ 30.00	\$ 42.00	\$
	PF10	Flowering Plants	Upon Request		\$
	PFA	Floral Arrangements	Upon Request		\$



Notes:

	TOTAL OF ALL ITEMS ORDERED:	\$
	5% GST:	\$
	PAYMENT ENCLOSED:	\$

All order governed by the GES payment policy & GES Terms & Conditions of Contract as specified in this Exhibitor's Kit.
Cancellation Policy: Items cancelled will be charged 50% of original price after move-in begins and 100% after installation.

COMPANY NAME

EMAIL ADDRESS

BOOTH#

AUTHORIZED SIGNATURE

AUTHORIZED CONTACT

DATE

X

All orders are governed by the GES Payment Policy and GES Terms & Conditions of Contract as specified in this Exhibitor Kit.

Graphics & Signage Order Form

7730 - 34th Street NW, Edmonton, AB T6B 3J6 Phone: 877.505.7767 Fax: 877.469.1619 www.gesexpo.ca edmonton@ges.com

PRICE LIST

Quantity	Item #	Description	Discount \$	Regular \$	Total Price
Standard Signs					
	S1114	11" x 14"	\$ 41.00	\$ 57.00	\$
	S1422	14" x 22"	\$ 57.00	\$ 80.00	\$
	S2228	22" x 28"	\$ 89.00	\$ 125.00	\$
	S744	7" x 44"	\$ 57.00	\$ 80.00	\$
	S2844	28" x 44"	\$ 153.00	\$ 214.00	\$
	SMISC	10" x 60"	\$ 88.00	\$ 123.00	\$
	SMISC	20" x 60"	\$ 150.00	\$ 210.00	\$
	SMISC	40" x 60"	\$ 233.00	\$ 326.00	\$
	SMISC	48" x 96"	\$ 425.00	\$ 595.00	\$

All standard signs are digitally produced on coroplast. Standard signs include up to 10 words and a selection of colours.

Please Indicate Choice

Background Colour <input type="checkbox"/> Black <input type="checkbox"/> Blue <input type="checkbox"/> Green <input type="checkbox"/> Red <input type="checkbox"/> White <input type="checkbox"/> Yellow	Copy Colour <input type="checkbox"/> Black <input type="checkbox"/> Blue <input type="checkbox"/> Green <input type="checkbox"/> Red <input type="checkbox"/> White <input type="checkbox"/> Yellow	Indicate Physical Alignment <div style="display: flex; align-items: center; margin-bottom: 10px;"> <div style="border: 1px solid black; width: 40px; height: 15px; margin-right: 10px;"></div> Horizontal </div> <div style="display: flex; align-items: center;"> <div style="border: 1px solid black; width: 15px; height: 40px; margin-right: 10px;"></div> Vertical </div>
--	--	--

Custom Signs

GES maintains a fully-equipped graphics shop that offers:

Graphic Design	Graphics Presentation	Lamination
Desktop Publishing	Large Format Printing	Logo Reproduction
Backlit Graphics	Vinyl Graphics	Vinyl Banners

For custom work and quotations, please call the GES office listed above.

COMPLETE COPY

Notes:

TOTAL OF ALL ITEMS ORDERED: \$

5% GST: \$

PAYMENT ENCLOSED: \$

All orders governed by the GES payment policy & GES Terms & Conditions of Contract as specified in this Exhibitor's Kit.

Cancellation Policy: Orders cancelled will be charged at 100% of original cost once production has started.

COMPANY NAME	EMAIL ADDRESS	BOOTH #
AUTHORIZED SIGNATURE	AUTHORIZED CONTACT	DATE
X		

Graphics & Signage Information

7730 - 34th Street NW, Edmonton, AB T6B 3J6 Phone: 877.505.7767 Fax: 877.469.1619 www.gesexpo.ca edmonton@ges.com

Sending your graphic and image files to the GES Creative Services Department

We want your graphics and images to look their absolute best. We are committed to partnering with you in order to provide the most comprehensive and effective solutions in the trade show industry. The graphic print and production industry is continuously evolving and in order to insure the best quality graphics and images from your digital files and to make file transfers as seamless as possible, we are pleased to provide you with the guidelines for submission of your art to GES. If you are unable to provide digital artwork for your signage needs, GES is capable of providing you with layout services. Additional fees will apply. Contact your GES representative for details.

Acceptable Media: All media should be formatted for use on a PC*

- Floppy disk - 3.5"
- CD-ROM (CD-R or CD-RW)
- DVD-ROM (DVD-R only)
- Email attachment (limited to maximum size of 2mb)

When sending disks, label them as follows: *Exhibitor Name / Show / Show Date / City of Event*

** For disk types not listed above, please contact a Creative Services Professional (see the *Still have Questions? Section Below)*

Acceptable File Formats**

VECTOR

This type of artwork is resolution independent and hence can be enlarged or reduced without any loss of quality.

<u>EXTENSION</u>	<u>PROGRAM</u>	<u>VERSION</u>
.cdr	Corel Draw	Version 11.0 or earlier
.eps	Encapsulated Postscript	An export option of various programs (vector .eps preferred)
.ai	Adobe Illustrator	Version CS.2 or earlier

BITMAP: If you have bitmap art, it is best to save your artwork in a 1 to 1 (full size) output ratio at 150 - 300 dpi. Lower resolutions or ratios will result in lower image quality. File size should not exceed 100 MB.

AVOIDING ADDITIONAL COSTS: Files obtained from the internet (.jpg or.gif) or artwork created in MS Office applications (Word, Excel, PowerPoint, etc.) are often not suitable for high quality output, and often require additional hourly charges. To avoid additional costs associated with these file types, please supply files in accordance with the defined criteria list above.

*** For file types not listed here (QuarkExpress, FreeHand, InDesign or .PDF files), please contact a Creative Services Professional*

Typeface/Font Handling

Convert all fonts to outlines before saving your file for transfer. If you do not convert your font to outlines, font substitution will occur, resulting in unexpected output. Remember that once fonts are converted to outlines they are no longer editable.

Proofs and Colours:

IMPORTANT: *Always send 100% accurate proofs (colour laser prints) with your disk. Identify all specific spot colours (PMS) within your file and on the provided proofs. In the absence of colour specifications, all graphics will be produced as is without colour corrections.*

Still Have Questions?

If you still have questions or concerns about your artwork, file formats and method of delivery, please call the GES office listed above and ask to speak to a Creative Services Representative.



IEEE ESTMP TRADE SHOW

March 19 - 20, 2012
Mayfield Trade Centre

E12-8A

DEADLINE DATE:
March 5, 2012

GEM Exhibit System Order Form

7730 - 34th Street NW, Edmonton, AB T6B 3J6 Phone: 877.505.7767 Fax: 877.469.1619 www.gesexpo.ca edmonton@ges.com

PRICE LIST

Quantity	Item #	Description	Discount \$	Regular \$	Total Price
GEM Exhibits					
	GGRE	GEM Model # 1 - 10' x 10' Corner	\$ 1,035.00	\$ 1,450.00	\$
	GGRE	GEM Model # 2 - 10' x 10' Corner	\$ 1,113.00	\$ 1,558.00	\$
	GGRE	GEM Model # 3 - 10' x 10'	\$ 1,185.00	\$ 1,659.00	\$
	GGRE	GEM Model # 4 - 10' x 10'	\$ 1,409.00	\$ 1,973.00	\$
	GGRE	GEM Model # 5 - 10' x 10'	\$ 1,508.00	\$ 2,111.00	\$
	GGRE	GEM Model # 6 - 10' x 20'	\$ 2,044.00	\$ 2,862.00	\$
	GGRE	GEM Model # 7 - 10' x 20'	\$ 2,616.00	\$ 3,662.00	\$
	GGRE	GEM Model # 8 - 10' x 20'	\$ 2,189.00	\$ 3,065.00	\$
	GGRE	GEM Model # 9 - 10' x 20'	\$ 2,423.00	\$ 3,392.00	\$
	GGRE	GEM Model # 10 - 10' x 20' Corner	\$ 2,938.00	\$ 4,113.00	\$

Package Includes: Installation and Dismantling, Choice of Panel Colour, Choice of Carpet Colour, Company ID Sign

Please Indicate Choice

Carpet Colour	Infill Panel Colour	Font Style	Font Colour
<input type="checkbox"/> Black	<input type="checkbox"/> Black	<input type="checkbox"/> Futura	<input type="checkbox"/> Black
<input type="checkbox"/> Blue	<input type="checkbox"/> Blue	<input type="checkbox"/> Humanist	<input type="checkbox"/> Blue
<input type="checkbox"/> Green	<input type="checkbox"/> Burgundy	<input type="checkbox"/> PosterBodini	<input type="checkbox"/> Burgundy
<input type="checkbox"/> Grey	<input type="checkbox"/> Green	<input type="checkbox"/> Times New Roman	<input type="checkbox"/> Green
<input type="checkbox"/> Red	<input type="checkbox"/> Grey	<input type="checkbox"/> Arial	<input type="checkbox"/> Red
	<input type="checkbox"/> White		<input type="checkbox"/> Teal

Identification Sign(s) To Read:

Models 1, 2, 3, 4, 5, 6, 8 or 9	COMPLETE COPY	Centre:
Models 7 or 10	COMPLETE COPY	Left:
		Right:

Indicate Date & Time of Arrival

Date: _____ Time: _____

Notes:	TOTAL OF ALL ITEMS ORDERED:	\$
	5% GST	\$
	PAYMENT ENCLOSED:	\$

All orders governed by the GES payment policy & GES Terms & Conditions of Contract as specified in this Exhibitor's Kit.

Cancellation Policy: Due to material and labour costs, order cancelled before move-in begins will be charge 50% of original price. Similarly, order cancelled after move-in begins will be charge 100%

COMPANY NAME	EMAIL ADDRESS	BOOTH #
AUTHORIZED SIGNATURE	AUTHORIZED CONTACT	DATE
X		

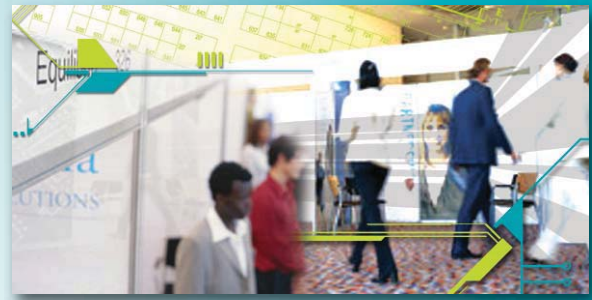

standard exhibit rentals

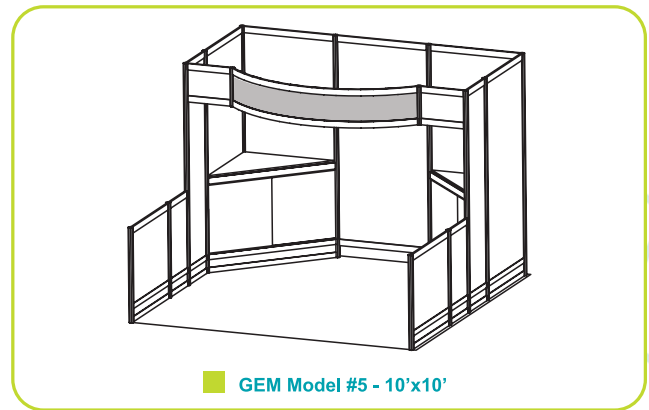
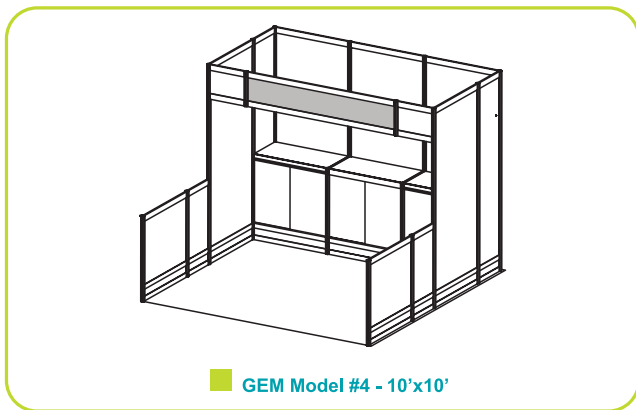
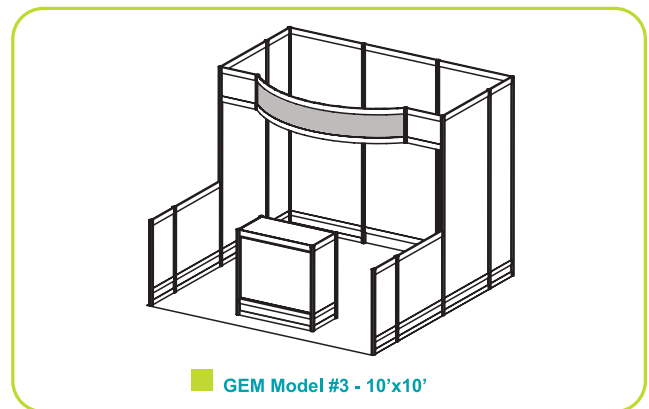
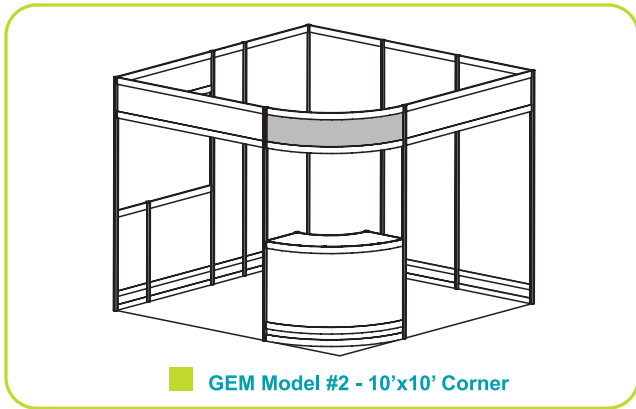
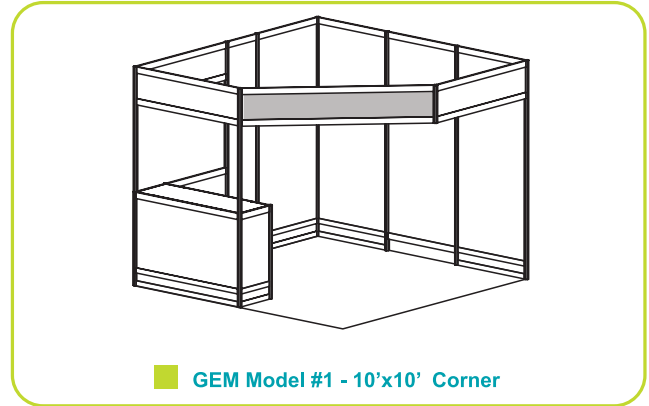

3 Easy Steps

- 1 Select the model number that suits your needs
- 2 Choose carpet and panel colours on the GEM Exhibit Rental order form
- 3 Complete & send order form

Grey indicates standard header sign(s)



standard exhibit rentals

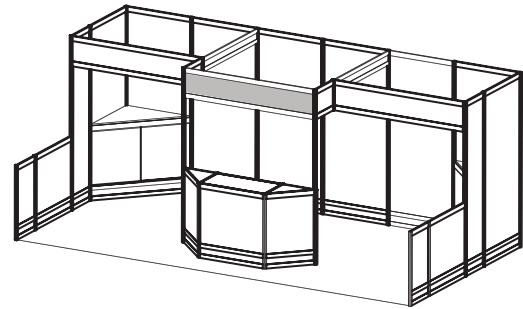

■ GEM Model #6 - 10'x20'

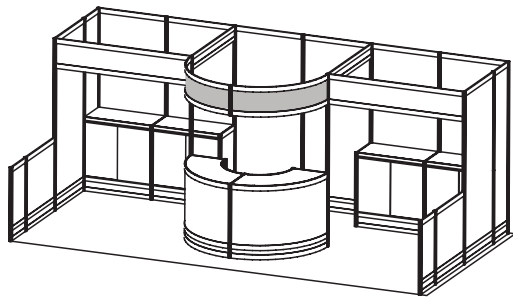

■ GEM Model #7 - 10'x20'

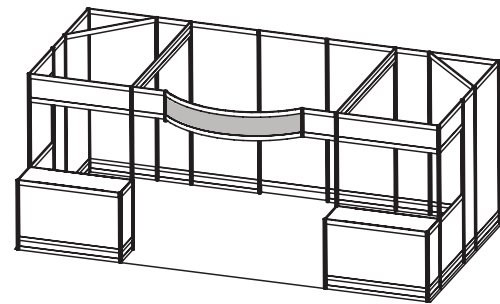

■ GEM Model #8 - 10'x20'

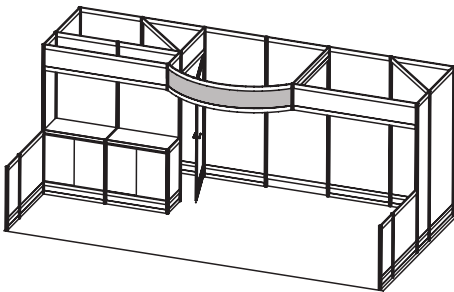

■ GEM Model #9 - 10'x20'

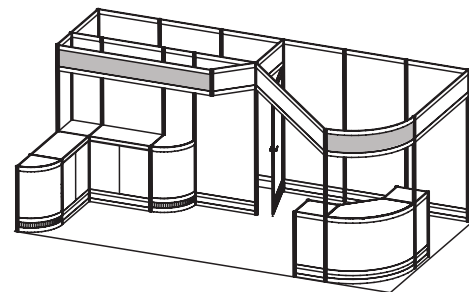

■ GEM Model #10 - 10'x20' Corner

3 Easy Steps →

- ① Select the model number that suits your needs
- ② Choose carpet and panel colours on the GEM Exhibit Rental order form
- ③ Complete & send order form

Grey indicates standard header sign(s)

GEM Accessories Order Form

7730 - 34th Street NW, Edmonton, AB T6B 3J6 Phone: 877.505.7767 Fax: 877.469.1619 www.gesexpo.ca edmonton@ges.com

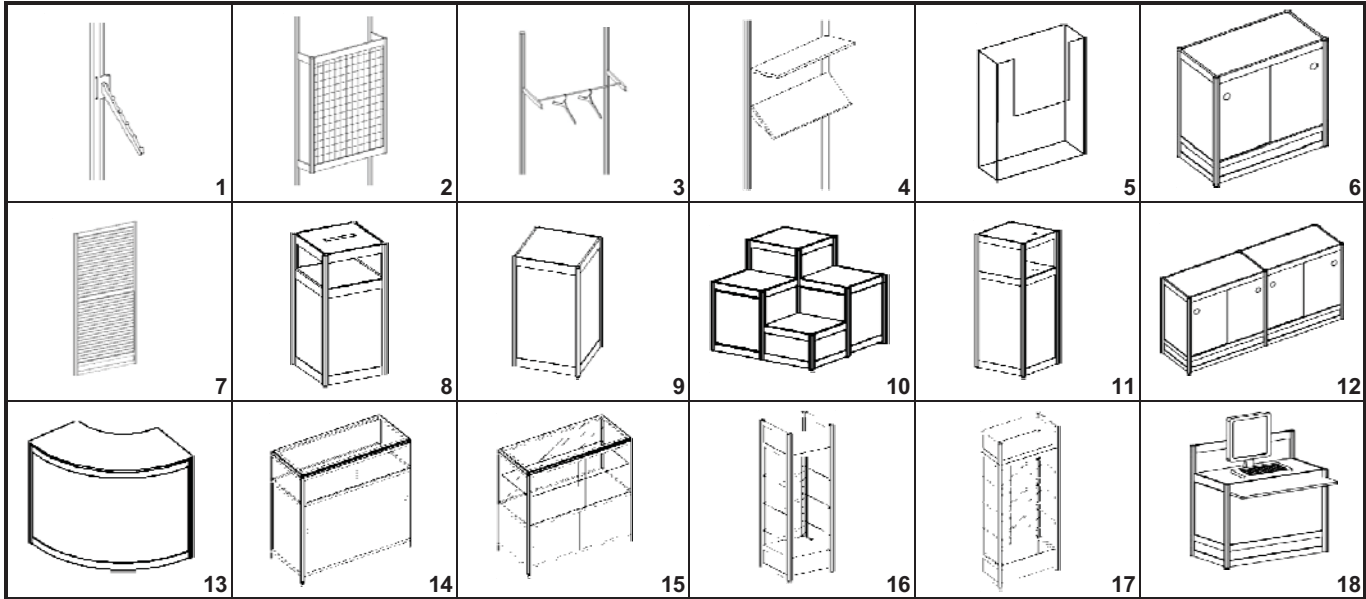
GEM EXHIBIT ACCESSORIES

PRICE LIST

Quantity	Item #	Description	Discount \$	Regular \$	Total Price
	1	Waterfall with eight balls	\$ 16.00	\$ 22.00	\$
	2	Grid Panel - 24" x 72" (2" squares)	\$ 30.00	\$ 42.00	\$
	3	Garment Rail 39" wide	\$ 41.00	\$ 57.00	\$
	4	Shelves <input type="checkbox"/> Flat <input type="checkbox"/> Angled	\$ 35.00	\$ 49.00	\$
	5	8.5" x 11" Clear Plexi Literature Pocket	\$ 25.00	\$ 35.00	\$
	6	Counter Storage Unit	\$ 122.00	\$ 170.00	\$
	7	Slatwall Panels - 37"W X 96"H Grey (additional cost per panel)	\$ 96.00	\$ 134.00	\$
	8	Ballot Bin - 20"L X 20"W X 36"H	\$ 105.00	\$ 147.00	\$
	9	Pedestal White - 20"L X 20"W X 36"H	\$ 80.00	\$ 112.00	\$
	10	Pedestal White - 40"L X 40"W - Unit Heights - 16"/28"/41"	\$ 412.00	\$ 577.00	\$
	11	A/V Pedestal (White) 26"L X 26"W x 55"H	\$ 174.00	\$ 244.00	\$
	12	Storage Counter (White) 80"L X 20"W X 41"H	\$ 241.00	\$ 337.00	\$
	13	Curve Counter (White) 60"L X 20"W X 36"H	\$ 165.00	\$ 231.00	\$
	14	99A Showcase (White/Glass) 40"L X 20"W X 36"H	\$ 165.00	\$ 231.00	\$
	15	99B Showcase (White/Glass) 40"L X 20"W X 36"H	\$ 168.00	\$ 235.00	\$
	16	99C Showcase (White/Glass) 20"L X 20"W X 96"H	\$ 245.00	\$ 343.00	\$
	17	99D Showcase (White/Glass) 40"L X 20"W X 96"H	\$ 345.00	\$ 483.00	\$
	18	Computer Counter	\$ 139.00	\$ 195.00	\$

Notes:	TOTAL OF ALL ITEMS ORDERED:	\$
	5% GST:	\$
	PAYMENT ENCLOSED:	\$

All order governed by the payment policy & GES Terms & Conditions of Contract as specified in this Exhibitor's Kit.
 Cancellation Policy: Items cancelled will be charged 50% of original price after move-in begins and 100% after installation.

COMPANY NAME	EMAIL ADDRESS	BOOTH #
AUTHORIZED SIGNATURE	AUTHORIZED CONTACT	DATE
X		

GEM Show Special Order Form

7730 - 34th Street NW, Edmonton, AB T6B 3J6 Phone: 877.505.7767 Fax: 877.469.1619 www.gesexpo.ca edmonton@ges.com

GEM Show Special

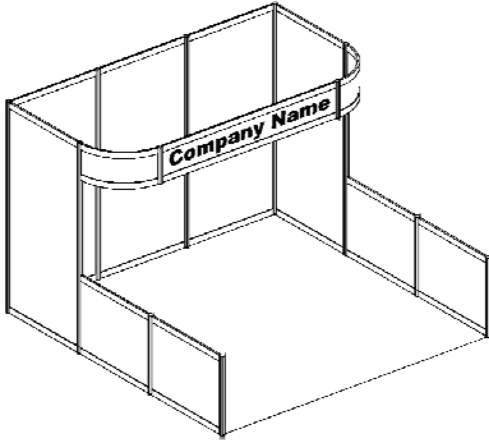

Includes:

- Header Sign
- White Infill Panels
- Carpet - Choice of Colour
- Installation & Dismantling

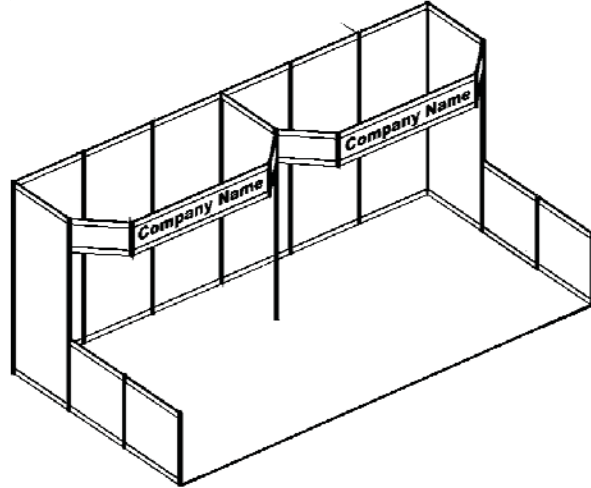

Includes:

- Header Sign
- White Infill Panels
- Carpet - Choice of Colour
- Installation & Dismantling

10' Show Special

20' Show Special

#	Description	Discount \$	Regular \$	#	Description	Discount\$	Regular \$
1	10' Show Special Rental Exhibit	\$ 860.00	\$ 1,200.00	2	20' Show Special Rental Exhibit	\$ 1,345.00	\$ 1,900.00

Please Indicate Choice

Please Indicate Choice

Header Sign

Header Sign

COMPLETE COPY →

COMPLETE COPY →

Carpet Colour

- Black Grey
 Blue Red
 Green

Carpet Colour

- Black Grey
 Blue Red
 Green

Notes:

TOTAL OF ALL ITEMS ORDERED: \$

5% PST \$

PAYMENT ENCLOSED: \$

All orders governed by the GES payment policy & GES Terms & Conditions of Contract as specified in this Exhibitor's Kit.

Cancellation Policy: Due to material and labour costs, order cancelled before move-in begins will be charge 50% of original price. Similarly, order cancelled after move-in begins will be charge 100%

COMPANY NAME	EMAIL ADDRESS	BOOTH #
AUTHORIZED SIGNATURE	AUTHORIZED CONTACT	DATE
X		

Installation & Dismantling Order Form

7730 - 34th Street NW, Edmonton, AB T6B 3J6 Phone: 877.505.7767 Fax: 877.469.1619 www.gesexpo.ca edmonton@ges.com

PLEASE COMPLETE THIS FORM FOR ALL DISPLAY LABOUR NEEDED.
TO DETERMINE IF YOU NEED DISPLAY LABOUR, PLEASE READ THIS FORM CAREFULLY

- Display Labour is used for installation and dismantling of exhibits, including signs and floor covering installation.

IMPORTANT INFORMATION & RATES

Starting time can be guaranteed only when labour is requested for the start of the working day at 8 AM. All exhibit labour for 8 AM starting times will be dispatched to booth space. For all other starting times, check in one-half (1/2) hour before time requested. Labour cancelled without a 24 hour notice shall be charged a one (1) hour cancellation fee per worker and forklift. If exhibitor fails to use the workers and equipment at the time confirmed, a one (1) hour "NO SHOW" charge per worker will apply.

The minimum charge for labour is one (1) hour per worker. Labour thereafter is charged in half (1/2) hour increments. GRATUITIES IN ANY FORM, INCLUDING CASH GIFTS, OR LABOUR HOURS FOR WORK NOT ACTUALLY PERFORMED ARE PROHIBITED BY GES. GES requires the highest standards of integrity from all employees. Please call our office at the above number to report fraudulent or unethical behavior. All rates are subject to change if necessitated by increased labour and materials costs.

HOURLY RATES	Times	Discount \$	Regular \$
Straight Time	Between 8:00 AM and 4:00 PM Weekdays	\$ 63.00	\$ 94.00
Over time	Before 8:00 AM and after 4:00 PM Weekdays and all day Saturdays, Sundays and Holidays.	\$ 94.00	\$ 132.00

The minimum charge for labour is one (1) hour per worker. Labour thereafter is charged in half (1/2) hour increments.

PLEASE INDICATE SERVICE PLACE ORDER HERE

- GES SUPERVISED (OK TO PROCEED)**
 GES CANADA will supervise labour to:
- Unpack and install display before exhibitor arrival at showsite.
 - Dismantle and pack display after show closing.
 - Subject to terms and conditions of all GES policies, including terms and conditions of contract, including but not limited to sub-paragraph VI. Labour.
- A 30% (\$50.00 minimum) surcharge will be added to the labour rates above for the professional supervision.*
- EXHIBITOR SUPERVISED (DO NOT PROCEED)**
 Exhibitor will supervise.
- Indicate workers needed for installation and dismantling.
 - GES will not be responsible for any loss or damage arising from the installation, unpacking, dismantlement or packing of exhibitor property.
- GES is responsible for the following type of booth:**
- Pop-up
 - Custom
 - Other:

SCHEDULE DATES	SCHEDULE START TIME	SCHEDULE END TIME	TOTAL # OF HOURS	LABOUR RATE	TOTAL
	AM	AM			\$
	PM	PM			\$
	AM	AM			\$
	PM	PM			\$
	AM	AM			\$
	PM	PM			\$

All orders are governed by the GES Payment Policy and GES Terms & Conditions of Contract as specified in this Exhibitor Kit.	1. Total Labour Ordered	\$
	2. 30% (\$50.00) GES Supervision	\$

Please estimate the number of workers and hours per worker needed for installation and dismantling above. Invoice will be calculated according to actual hours worked.

Notes:	TOTAL OF ALL ITEMS ORDERED:	\$
	5% GST:	\$
	PAYMENT ENCLOSED:	\$

All orders governed by the GES payment policy & GES Terms & Conditions of Contract as specified in this Exhibitor's Kit.

COMPANY NAME	EMAIL ADDRESS	BOOTH#
AUTHORIZED SIGNATURE X	AUTHORIZED CONTACT	DATE



IEEE ESTMP TRADE SHOW

March 19 - 20, 2012
Mayfield Trade Centre

E12-10

DEADLINE DATE:
March 5, 2012

In-Booth Forklift Order Form

7730 - 34th Street NW, Edmonton, AB T6B 3J6 Phone: 877.505.7767 Fax: 877.469.1619 www.gesexpo.ca edmonton@ges.com

**PLEASE COMPLETE THIS FORM FOR ALL IN-BOOTH FORKLIFT AND LABOUR NEEDED.
TO DETERMINE IF YOU NEED IN-BOOTH FORKLIFT AND LABOUR, PLEASE READ THIS FORM CAREFULLY.**

- In-Booth Forklift and Labour may be required to assemble displays or when uncrating, positioning, and reskidding equipment and machinery.
- A forklift is required for moving equipment and materials weighing 200 pounds or more.
- If you require a forklift, a crew will be assigned consisting of a forklift with an operator.

IMPORTANT INFORMATION & RATES

Starting time can be guaranteed only when labour is requested for the start of the working day at 8 AM. All exhibit labour for 8 AM starting times will be dispatched to booth space. Confirm labour and forklifts by 2:30 PM the day before date requested. Please have a representative pick up the crew at the service desk and supervise the work to be done. Upon completion, the exhibitor's representative will return the crew to the service desk and approve the work order. Equipment and labour cancelled without a 24 hour notice shall be charged a one (1) hour cancellation fee per worker and forklift. If exhibitor fails to use the workers and equipment at the time confirmed, a one (1) hour "NO SHOW" charge per worker and forklift will apply.

The minimum charge for labour and equipment is one (1) hour per worker and forklift. Equipment and labour thereafter is charged in half (1/2) hour increments. GRATUITIES IN ANY FORM, INCLUDING CASH GIFTS, OR LABOUR HOURS FOR WORK NOT ACTUALLY PERFORMED ARE PROHIBITED BY GES CANADA. GES CANADA requires the highest standards of integrity from all employees. Please call our office at the above number to report fraudulent or unethical behavior. All rates are subject to change if necessitated by increased labour and materials costs.

HOURLY RATES	Times	Forklift & Driver		Labourers	
		Discount \$	Regular \$	Discount \$	Regular \$
Straight Time	Between 8:00 AM and 4:00 PM Weekdays	\$ 95.00	\$ 127.00	\$ 63.00	\$ 87.00
Over time	Before 8:00 AM and after 4:00 PM Weekdays and all day Saturdays, Sundays and Holidays.	\$ 142.00	\$ 168.00	\$ 94.00	\$ 130.00

PLEASE INDICATE SERVICE

PLACE ORDER HERE

▶ **GES IS RESPONSIBLE FOR THE FOLLOWING:**

- Uncrating
- Unskidding
- Positioning
- Leveling
- Dismantling
- Recrating
- Reskidding

SCHEDULE DATES	SCHEDULE START TIME	SCHEDULE END TIME	TOTAL # OF HOURS	LABOUR RATE	TOTAL
	AM	AM			\$
	PM	PM			\$
	AM	AM			\$
	PM	PM			\$
	AM	AM			\$
	PM	PM			\$

All orders are governed by the GES Payment Policy and GES Terms & Conditions of Contract as specified in this Exhibitor Kit.

Please estimate the number of forklifts and/or workers and hours per forklift and/or worker needed for installation and dismantling above. Invoice will be calculated according to actual hours worked.

EXHIBITOR MUST BE PRESENT TO SUPERVISE

Notes:	TOTAL OF ALL ITEMS ORDERED:	\$
	5% GST:	\$
	PAYMENT ENCLOSED:	\$

All orders governed by the GES payment policy & GES Terms & Conditions of Contract as specified in this Exhibitor's Kit.

COMPANY NAME	EMAIL ADDRESS	BOOTH #
AUTHORIZED SIGNATURE	AUTHORIZED CONTACT	DATE

X



Advance Material Handling Order Form

7730 - 34th Street NW, Edmonton, AB T6B 3J6 Phone: 877.505.7767 Fax: 877.469.1619 www.gesexpo.ca edmonton@ges.com

ADVANCE WAREHOUSE SHIPMENTS

WAREHOUSE SHIPMENTS (up to 30 days free storage)

The rate for this service includes unloading at the warehouse and delivery to your booth at the: Mayfield Trade Centre

Rates include: Unloading freight, storing at warehouse for up to 30 days (any materials stored beyond 30 days will incur additional costs, applied to your invoice); reloading onto trucks and delivery to the exhibit site; unloading freight and delivery to your booth, picking up, storing and returning empty shipping containers; and reloading freight for return to your specified destination from exhibit site.

WEIGHT OF SHIPMENT WILL BE VERIFIED UPON DELIVERY

Crated Materials			
Service	Rates	Minimum Charge	
On Target Shipments	\$ 36.00 per cwt.	\$	108.00
Shipments after: 03/15/12	\$ 47.00 per cwt.	\$	141.00

Materials Requiring Special Handling			
Service	Rates	Minimum Charge	
On Target Shipments	\$ 47.00 per cwt.	\$	141.00
Shipments after: 03/15/12	\$ 61.00 per cwt.	\$	183.00

ARRIVAL DATES & SURCHARGES FOR SHIPMENTS:

Advance Date:

- **02/17/12** Advance shipments may begin to arrive at warehouse.
- **03/15/12** Last day for crated shipments to arrive at advance warehouse without surcharge.

PLEASE REFER TO THE SHIPPING LABELS IN THIS MANUAL

GES CANADA shall not be responsible for damage to improperly packed materials, concealed damage, loss or theft of exhibitor materials after being delivered to booth during installation; nor before being picked up for shipping out from the building. **Claims must be filed before the close of the show.**

If your designated carriers do not pick up or make destination delivery of your shipment on time, neither show management nor contractor will be liable for any resulting delays.

CALCULATION OF MATERIAL HANDLING CHARGES

We understand that your calculation is only an estimate. Invoicing will be done from the actual weight. Adjustments will be made accordingly.

Our shipment will be sent to the warehouse on date:	Total Pieces:
Carrier:	
Total Weight (200 lbs minimum per shipment):	/ 100 x Rate = \$

Payment & Credit Card Charge Authorization Form MUST Accompany this Form

I AGREE IN PLACING THIS ORDER THAT I HAVE READ AND ACCEPTED GES PAYMENT POLICY AND GES TERMS & CONDITIONS OF CONTRACT.	TOTAL ESTIMATED CHARGES: \$
	5% GST: \$
	PAYMENT ENCLOSED: \$

COMPANY NAME	EMAIL ADDRESS	BOOTH #
AUTHORIZED SIGNATURE X	AUTHORIZED CONTACT	DATE

Material Handling/Forklift & Driver Order Form

7730 - 34th Street NW, Edmonton, AB T6B 3J6 Phone: 877.505.7767 Fax: 877.469.1619 www.gesexpo.ca edmonton@ges.com

PLEASE COMPLETE THIS FORM FOR MATERIAL HANDLING SERVICES - FORKLIFT & DRIVER SERVICES ONLY.

- Material Handling Services will be provided to unload equipment and materials from transport trucks at the loading doors and deliver them to the exhibitors exhibit space.

IMPORTANT INFORMATION & RATES

- The minimum charge for labour and equipment is one (1) hour per worker and forklift. Equipment and labour thereafter is charged in half (1/2) hour increments. GRATUITIES IN ANY FORM, INCLUDING CASH GIFTS, OR LABOUR HOURS FOR WORK NOT ACTUALLY PERFORMED ARE PROHIBITED.
- It is the responsibility of the exhibitor or the exhibitor's agent to supply labourers to move crates to the back of the truck when ground unloading or loading occurs. If labourers are not provided by the exhibitor, GES will supply the required labourers at the rates below.
- GES shall not be liable for damage, loss, or delay to uncrated freight, freight improperly packed, glass breakage or concealed damage. GES shall not be liable for ordinary wear and tear in handling of Goods or for damage to shrink wrapped Goods. All Goods should be able to withstand handling by heavy equipment, including but not limited to forklifts, cranes, or dollies. It is the Customers' responsibility to ensure that Goods are packaged correctly prior to shipment or movement on or off the Show floor.

HOURLY RATES	Times	Forklift & Driver		Labourers	
		Discount \$	Regular \$	Discount \$	Regular \$
Straight Time	Between 8:00 AM and 4:00 PM Weekdays	\$ 95.00	\$ 128.00	\$ 63.00	\$ 87.00
Overtime	Before 8:00 AM and after 4:00 PM Weekdays and all day Saturdays, Sundays and Holidays.	\$ 142.00	\$ 168.00	\$ 94.00	\$ 130.00

PLACE ORDER HERE



SCHEDULE DATES	SCHEDULE START TIME	SCHEDULE END TIME
	AM	AM
	PM	PM
	AM	AM
	PM	PM
	AM	AM
	PM	PM
	AM	AM
	PM	PM

CARRIER: _____
OF PIECES: _____

All orders are governed by the GES Payment Policy and GES Terms & Conditions of Contract as specified in this Exhibitor Kit.

All orders governed by the GES payment policy & GES Terms & Conditions of Contract as specified in this Exhibitor's Kit.

COMPANY NAME	EMAIL ADDRESS	BOOTH #
AUTHORIZED SIGNATURE X	AUTHORIZED CONTACT	DATE



IEEE ESTMP TRADE SHOW

March 19 - 20, 2012
 Mayfield Trade Centre

E12-11P

DEADLINE DATE:
 March 5, 2012

Post Show Storage Order form

7730 - 34th Street NW, Edmonton, AB T6B 3J6 Phone: 877.505.7767 Fax: 877.469.1619 www.gesexpo.ca edmonton@ges.com

POST SHOW STORAGE SHIPMENTS

MATERIAL HANDLING CONTRACTOR:

GES CANADA EXPOSITION SERVICE (CANADA) LTD.
 7730 - 34TH STREET
 EDMONTON, ALBERTA T6B 3J6
 (877) 505-7767

The rate for this service includes removal of goods from the show floor and 23-Mar-12
 storage for up to three (3) days upon which time GES CANADA reserves the
 right to ship out your shipment "collect": via a carrier of our choice:

\$44.00 per 100 lbs - crated / \$88.00 minimum

Shipments must be picked up on March 23, 2012
or before:

Address Label	
Ship To:	_____
Address:	_____

City:	_____
Prov/State	_____
Country	_____
Postal Code:	_____
Phone	_____
Contact Name:	_____

Please refer to the shipping labels in this manual.

GES CANADA shall not be responsible for damage to uncrated materials, improperly packed materials, concealed damage, loss or theft of exhibitor materials prior to GES staff collecting goods from the booth during move out. **Claims must be filed before the close of show.**

If your designated carriers do not pick up or make destination delivery of your shipment on time, neither show management nor contractor will be liable for any resulting delays.

CALCULATION OF MATERIAL HANDLING CHARGES

We understand that your calculation is only an estimate. Invoicing will be done from the actual weight. Adjustments will be made accordingly.

Carrier:		Total Pieces:	
Total Weight (200 lbs minimum per shipment):	/ 100	x \$44.00	= \$

Payment & Credit Card Charge Authorization Form MUST Accompany this Form

I AGREE IN PLACING THIS ORDER THAT I HAVE READ AND ACCEPTED GES PAYMENT POLICY AND GES CANADA TERMS & CONDITIONS OF CONTRACT.	TOTAL ESTIMATED CHARGES:	\$
	5% GST:	\$
	PAYMENT ENCLOSED:	\$

COMPANY NAME	EMAIL ADDRESS	BOOTH #
AUTHORIZED SIGNATURE	AUTHORIZED CONTACT	DATE
X		



Material Handling Information

7730 - 34th Street NW, Edmonton, AB T6B 3J6 Phone: 877.505.7767 Fax: 877.469.1619 www.gesexpo.ca edmonton@ges.com

Material Handling is the unloading of your exhibit materials, delivery to your booth, handling of empty containers to and from storage, and removal of your materials from your booth for reloading onto your outbound carrier. This is not to be confused with the cost to transport your exhibit material to and from the event.

Benefits of Advance Shipping to the GES CANADA Warehouse

- Storage of materials for up to 30 days prior to your show.
- Delivery of Shipments to your booth by 8:00 AM on your first day of move-in (schedule permitting).
- Some convention centres and hotels do not have facilities for receiving or storing freight.
- Saves valuable set-up time.

How to ship in Advance to the GES CANADA Warehouse

- Remove all old shipping and empty storage labels.
- Fill out and attach enclosed Advance Shipping Labels.
- Complete the enclosed Advance Material Handling order form.
- All shipments must have a bill of lading or delivery slip showing the number of pieces, weight, and type of merchandise.
- Take the time to ensure that your display and products are packed neatly and securely.
- Do not ship uncrated materials to the warehouse.

How to Ship to Exhibit Site

- Consign all shipments c/o GES CANADA.
- Remove all old shipping and empty storage labels.
- Fill out and attach enclosed Direct Shipping labels.
- All shipments must have a bill of lading or delivery slip showing the number of pieces, weight, and type of merchandise.
- Take the time to ensure that your display and products are packed neatly and securely.
- If you are shipping your carpet and/or lighting trusses, make sure it is loaded last so it can be unloaded first.

Freight Carriers

Select a carrier with experience in handling exhibition materials. Make sure to give your carrier explicit information as to where and when to check-in. Delivery and pick up times are often out of the range of "normal" deliver hours, make sure your carrier is committed to meeting your target dates and times. While making shipping plans to the Show, also plan for the return shipment.

Tracking Shipments

Confirm your delivery date and time with your carrier, and have all pertinent shipping information in the hands of your representative at showsite. You may also want to review the return of your goods at the end of the show.

Estimating Material Handling Charges

Handling charges are based on the weight of the freight. Shipments are billed by the hundred weight and rounded up to the nearest hundred. Minimum per shipment may apply, see enclosed Material Handling Order Form for details. Please prepay all shipping charges - GES CANADA cannot accept or be responsible for collect shipments. Crated and uncrated shipments must be separated and clearly identified on your bill of lading.

Crated - Material that is skidded, or is any type of shipping container that can be unloaded at the dock with no additional handling required.

Uncrated - Material that is shipped loose or pad-wrapped, and/or unskidded machinery without proper lifting bars or hooks.

Special Handling - Defined as shipments that are loaded by cubic space and/or packed in such a manner as to require special handling, such as ground loading, side door loading, constricted space loading, and designated piece loading or stacked shipments. Also included are mixed shipments and shipments without proper delivery receipts.

Overtime Surcharges - Shows that move-in or move-out on weekends or late in the day may be subject to overtime surcharges. See enclosed Material Handling Order Form for details.

Late Surcharges - A surcharge may apply if advance freight is received after the published deadline date for shipments to arrive at the warehouse. See enclosed Material Handling Order Form for details.

Storing Empty Containers

Properly labeled empty shipping cartons will be picked up, stored and returned after the show. Labels are available at the **GES CANADA Servicentre** or from your GES Service Executive and are for empty storage only. Depending on the size of the show, it can take from one (1) to four (4) hours to return empty crates. Do not store any items in crates marked empty.

Outgoing Shipments

An OMHF (Outbound Material Handling Form / Bill of Lading) must accompany all outgoing shipments. Shipping information, outbound forms and labels will be available at the **GES CANADA Servicentre**. Exhibitors selecting non-official carriers will need to make their own arrangements for pickup. Make sure that someone from your company will be on-site to oversee the outbound shipment of your display and product.

Machinery Labour and Equipment

Labour and equipment for uncrating, unskidding, positioning, leveling, dismantling, recrating, and reskidding machinery and/or equipment must be ordered separately. Place your order for this using the In-Booth Forklift and Labour Order Form. If your material requires specialized rigging equipment, please notify us promptly so that we can make arrangements. When possible supply your own rigging equipment with shipments and pre-rig your material

Insurance

All of your goods should be insured by your own insurance policy. Although we do our best to handle your goods as our own, there are many variables in shipping and handling that can affect your exhibit and products. GES CANADA has published GES CANADA Terms & Conditions of Contract that are in your exhibitor service manual. Please read them carefully. It is recommended that your goods be insured.

Customs & Brokerage Fees

GES CANADA is not responsible for the brokerage fees, duty or GST resulting from exhibitor materials entering Canada from another country. GES CANADA is not responsible for any delays in delivery of exhibitor materials to show site or the advance warehouse due to Canada Custom inspections or delays resulting from insufficient or improper documentation for shipments entering Canada from another country.

GES CANADA Limits of Liability

Liability - GES is liable for loss or damage to your goods ONLY if the loss or damage was caused by GES CANADA negligence.

Measure of Damage - If GES CANADA was negligent and the negligence caused either loss or damage to your goods, then the measure of that damage will be determined by the following:

- Measure of damages in all situations (including b. below) will be limited by the Depreciated Value of the goods or repair costs, whichever is less.
- The lesser of \$0.30 per pound per piece, \$50 per piece, or \$1000 per occurrence.

GES CANADA does not offer or sell insurance. GES CANADA is not liable and will not owe for loss or damage to your goods if the damage was not caused by GES CANADA.

RUSH!

EXHIBITION FREIGHT

FROM:

ADVANCE SHIPMENT

WAREHOUSE HOURS ARE MON - FRI 8:00 AM - 4:30 PM. DRIVERS MUST CHECK-IN BY 2:00 PM TO BE GUARANTEED SAME-DAY UNLOADING

TO: _____

EXHIBITING COMPANY

IEEE ESTMP TRADE SHOW

NAME OF EXHIBITION

BOOTH NUMBER

C/O GES CANADA EXPOSITION SERVICES LTD.
7730 - 34TH STREET NW
EDMONTON, ALBERTA T6B 3J6

SHIPMENT SHOULD ARRIVE ON OR BEFORE
March 15, 2012

Carrier _____

Number _____ of pieces 

RUSH!

EXHIBITION FREIGHT

FROM:

ADVANCE SHIPMENT

WAREHOUSE HOURS ARE MON - FRI 8:00 AM - 4:30 PM. DRIVERS MUST CHECK-IN BY 2:00 PM TO BE GUARANTEED SAME-DAY UNLOADING

TO: _____

EXHIBITING COMPANY

IEEE ESTMP TRADE SHOW

NAME OF EXHIBITION

BOOTH NUMBER

C/O GES CANADA EXPOSITION SERVICES LTD.
7730 - 34TH STREET NW
EDMONTON, ALBERTA T6B 3J6

SHIPMENT SHOULD ARRIVE ON OR BEFORE
March 15, 2012

Carrier _____

Number _____ of pieces 

RUSH!

EXHIBITION FREIGHT

FROM:

ADVANCE SHIPMENT

WAREHOUSE HOURS ARE MON - FRI 8:00 AM - 4:30 PM. DRIVERS MUST CHECK-IN BY 2:00 PM TO BE GUARANTEED SAME-DAY UNLOADING

TO: _____

EXHIBITING COMPANY

IEEE ESTMP TRADE SHOW

NAME OF EXHIBITION

BOOTH NUMBER

C/O GES CANADA EXPOSITION SERVICES LTD.
7730 - 34TH STREET NW
EDMONTON, ALBERTA T6B 3J6

SHIPMENT SHOULD ARRIVE ON OR BEFORE
March 15, 2012

Carrier _____

Number _____ of pieces 

RUSH!

EXHIBITION FREIGHT

FROM:

ADVANCE SHIPMENT

WAREHOUSE HOURS ARE MON - FRI 8:00 AM - 4:30 PM. DRIVERS MUST CHECK-IN BY 2:00 PM TO BE GUARANTEED SAME-DAY UNLOADING

TO: _____

EXHIBITING COMPANY

IEEE ESTMP TRADE SHOW

NAME OF EXHIBITION

BOOTH NUMBER

C/O GES CANADA EXPOSITION SERVICES LTD.
7730 - 34TH STREET NW
EDMONTON, ALBERTA T6B 3J6

SHIPMENT SHOULD ARRIVE ON OR BEFORE
March 15, 2012

Carrier _____

Number _____ of pieces 

E12-11A

USE THESE SHIPPING LABELS AS THEY WILL EXPEDITE HANDLING. Copies of these labels are acceptable if additional labels are needed.

RUSH!

EXHIBITION FREIGHT

FROM:

DIRECT SHIPMENT

TO: _____
EXHIBITING COMPANY
Enter Show Name Here

NAME OF EXHIBITION

BOOTH NUMBER

C/O GES CANADA EXPOSITION SERVICES LTD.
 Mayfield Trade Centre
 16615 - 109 Avenue
 Edmonton, AB T5P 4K8

IMPORTANT! PLEASE REFER TO THE MOVE-IN DATES IN THIS EXHIBITOR'S KIT

Carrier _____

Number _____ of _____ pieces 

RUSH!

EXHIBITION FREIGHT

FROM:

DIRECT SHIPMENT

TO: _____
EXHIBITING COMPANY

NAME OF EXHIBITION

BOOTH NUMBER

C/O GES CANADA EXPOSITION SERVICES LTD.
 Mayfield Trade Centre
 16615 - 109 Avenue
 Edmonton, AB T5P 4K8

IMPORTANT! PLEASE REFER TO THE MOVE-IN DATES IN THIS EXHIBITOR'S KIT

Carrier _____

Number _____ of _____ pieces 

RUSH!

EXHIBITION FREIGHT

FROM:

DIRECT SHIPMENT

TO: _____
EXHIBITING COMPANY
Enter Show Name Here

NAME OF EXHIBITION

BOOTH NUMBER

C/O GES CANADA EXPOSITION SERVICES LTD.
 Mayfield Trade Centre
 16615 - 109 Avenue
 Edmonton, AB T5P 4K8

IMPORTANT! PLEASE REFER TO THE MOVE-IN DATES IN THIS EXHIBITOR'S KIT

Carrier _____

Number _____ of _____ pieces 

RUSH!

EXHIBITION FREIGHT

FROM:

DIRECT SHIPMENT

TO: _____
EXHIBITING COMPANY
Enter Show Name Here

NAME OF EXHIBITION

BOOTH NUMBER

C/O GES CANADA EXPOSITION SERVICES LTD.
 Mayfield Trade Centre
 16615 - 109 Avenue
 Edmonton, AB T5P 4K8

IMPORTANT! PLEASE REFER TO THE MOVE-IN DATES IN THIS EXHIBITOR'S KIT

Carrier _____

Number _____ of _____ pieces 

USE THESE SHIPPING LABELS AS THEY WILL EXPEDITE HANDLING. Copies of these labels are acceptable if additional labels are needed.

Electrical & Lighting Order form

7730 - 34th Street NW, Edmonton, AB T6B 3J6 Phone: 877.505.7767 Fax: 877.469.1619 www.gesexpo.ca edmonton@ges.com

PRICE LIST

Quantity	Item #	Description	Discount \$	Regular \$	Total Price
Electrical - 110 Volt					
	EL1500W	1500 Watt Duplex Outlet	\$ 67.00	\$ 93.00	\$

Electrical - 220 Volt - Single Phase					
	ELMISC	220 V / 20 Amp Single Phase	\$ 150.00	\$ 210.00	\$
	ELMISC	220V / 30 Amp Single Phase	\$ 180.00	\$ 252.00	\$
	ELMISC	220V / 50 Amp Single Phase	\$ 225.00	\$ 315.00	\$
	ELMISC	220V / 100 Amp Single Phase	\$ 403.00	\$ 564.00	\$

Electrical - 208 Volt - Three Phase					
	ELMISC	208 Volt / 20 Amp Three Phase	\$ 260.00	\$ 364.00	\$
	ELMISC	208 Volt / 30 Amp Three Phase	\$ 320.00	\$ 448.00	\$

Electrical - Miscellaneous Requirements					
	ELPB	Power Bars	\$ 16.00	\$ 22.00	\$
	ELEC	Extension Cords	\$ 18.00	\$ 25.00	\$

Lighting (Does Not Include Power)					
	ELD150F	Flood Light Stand, 2 - 75 Watt Flood Bulbs	\$ 60.00	\$ 84.00	\$
	ELMISC	Clamp-on, 1 - 75 Watt Flood Bulb	\$ 26.00	\$ 36.00	\$
	ELQL	500 Watt Quartz Light	\$ 77.00	\$ 108.00	\$
	ELMISC	Special Hookups & Specialty Lighting Available upon request			\$

Please Note the Following:

- 24 Hour power - add 50% to the above prices
- Outside power - add 100% to the above prices
- Electrician Charge Extra, If Required
- Additional labour charges may apply for special connections or special wiring

Payment & Credit Card Charge Authorization Form MUST Accompany this Form

Notes:	TOTAL OF ALL ITEMS ORDERED:	\$
	5% GST:	\$
	PAYMENT ENCLOSED:	\$

All orders governed by the GES CANADA payment policy & GES CANADA Terms & Conditions of Contract as specified in this Exhibitor's Kit.
 Cancellation Policy: Orders cancelled will be charged 50% of original price after move-in and 100% of original price after installation.

COMPANY NAME	EMAIL ADDRESS	BOOTH #
AUTHORIZED SIGNATURE	AUTHORIZED CONTACT	DATE

GES CANADA Terms & Conditions of Contract (Page 1 of 2)

GES CANADA TERMS AND CONDITIONS ARE
SUBJECT TO CHANGE AT GES' DISCRETION
WITHOUT NOTICE TO ANY PARTIES

7730 - 34th Street NW, Edmonton, AB T6B 3J6 Phone: 877.505.7767 Fax: 877.469.1619 www.gesexpo.ca edmonton@ges.com

I. Definitions:

Agents: GES CANADA's agents, sub-contractors, carriers, and the agents of each.

Customer: Exhibitor or other party requesting services from GES CANADA.

Carrier: Motor carrier, van line, air carrier, or air or surface carrier/freight forwarder.

Shipper: Party who tenders Goods to Carrier for transportation.

Goods: Exhibits, property, and commodities of any type for which GES CANADA is requested to perform services.

Cold Storage: Holding of Goods in a climate controlled area.

Accessible Storage: Holding of Goods in an area from which Goods may be removed during shows.

Services: Warehousing, transportation, drayage, un-supervised labour, supervised labour and/or related services.

Show Site: The venue or place where an exposition or event takes place.

Supervised Labour: Labour that is provided to a Customer to install or dismantle a booth or exhibit space, and is supervised and/or directed by GES CANADA.

Un-Supervised Labour: Labour that is provided to a Customer to install or dismantle a booth or exhibit space and per Customer's election is not supervised and/or directed by GES CANADA. Customer assumes the responsibility for the work of labour when Customer elects to use unsupervised labour.

II. Scope:

These Terms and Conditions shall be binding upon Customer, GES CANADA, and their respective Agents and representatives, including but not limited to Customer contracted labour such as Customer Appointed Contractors and Installation and Dismantle Companies, and any other party with an interest in the Goods. Each shall have the benefit of and be bound by all provisions stated herein, including but not limited to time limits and limitations of liability.

By acceptance of services of GES CANADA or Agents, Customer and any other party with an interest in the Goods agree to these Terms and Conditions.

III. Customer Obligations:

Payment for Services: Customer shall be liable for all unpaid charges for services performed by GES CANADA or Agents. Customer authorizes GES CANADA to charge its' credit card directly for services rendered on its' behalf after departure, by placing an order on-line, via fax, phone, or through a work order on site.

Credit Terms: All charges are due before Services are performed unless other arrangements have been made in advance. GES CANADA has the right to require prepayment or guarantee of the charges at the time of request for Services. A failure to pay timely will result in Customer having to pay in cash in advance for future services. If a credit provided to GES CANADA, GES CANADA is authorized to bill to such credit card any unpaid charges for services provided Customer, including charges for return shipping. Any charges not paid within 30 days of deliver will be subject to interest at 1.5% per month until paid.

IV. Mutual Obligations:

Indemnification:

Customer to GES CANADA: Except to the extent of GES CANADA's own negligence and/or willful misconduct, Customer shall defend, hold harmless and indemnify GES CANADA from and against any claims, lawsuits, demands, liability, costs, and expenses, including reasonable attorney's fees and court costs, resulting from any injury to or death of persons, or damage to property, relating to or arising from performance under this Agreement.

Customer agrees to indemnify and hold GES CANADA harmless for any and all acts of its representatives and agents,

including but not limited to Customer Appointed Contractors and Installation and Dismantle Companies, any subtenant or other user of its' space or any agents or employees engaged in business on its' behalf of Customer or present at Customers' invitation.

GES CANADA to Customer: To the extent of GES CANADA's own negligence and/or willful misconduct, and subject to the limitations of liability below, GES CANADA shall defend, hold harmless and indemnify Customer from and against any claims, lawsuits, demands, liability, costs and expenses, including reasonable attorney's fees and court costs, resulting from any injury to or death of persons, or damage to property other than Goods. GES CANADA assumes no liability for bodily injury resulting from Customer's presence in areas which have been marked as "off limits to exhibitors" and during hours and days when exhibitors are present in the facility, prior to the start of and after the conclusion of their space lease with show management.

V. No liability for consequential damages. UNDER NO CIRCUMSTANCES WILL ANY PARTY BE LIABLE FOR SPECIAL, INCIDENTAL, CONSEQUENTIAL OR PUNITIVE DAMAGES, INCLUDING BUT NOT LIMITED TO LOSS OF PROFITS OR INCOME.

VI. GES CANADA Liability for Loss or Damage to Goods

Negligence standard: GES CANADA shall be liable, subject to the limitations contained herein, for loss or damage to Goods only if such loss or damage is caused by the direct negligence or willful misconduct of GES CANADA.

Condition of Goods: GES CANADA shall not be liable for damage, loss, or delay to uncrated freight, freight improperly packed, glass breakage or concealed damage. GES CANADA shall not be liable for ordinary wear and tear in handling of Goods or for damage to shrink wrapped Goods. All Goods should be able to withstand handling by heavy equipment, including but not limited to forklifts, cranes, or dollies. It is the Customers' responsibility to ensure that Goods are packaged correctly prior to shipment or movement on or off the Show floor.

Receipt of Goods: GES CANADA shall not be liable for Goods received without receipts, freight bills, or specified unit counts on receipts or freight bills. Such Goods shall be delivered to booth without the guarantee of piece count or condition.

Force Majeure: GES CANADA shall not be liable for loss or damage that results from Acts of God, weather conditions, act or default of Customer, shipper, or the owner of the Goods, inherent nature of the Goods, public enemy, public authority, labour disputes, and acts of terrorism or war.

Cold Storage: Goods requiring cold storage are stored at Customer's own risk. GES CANADA assumes no liability or responsibility for Cold Storage.

Accessible Storage: GES CANADA assumes no liability for loss or damage to Goods while in Accessible Storage. Storage charges are for the use of space and are not a form of insurance, or a guarantee of security.

Unattended Goods: GES CANADA assumes no liability for loss or damage to unattended Goods received at Show Site at any time from the point of receipt of inbound Goods until the loading of the outbound Goods, including the entire term of the respective show or exhibition. Customer is responsible for insuring its' own Good for any and all risk of loss.

Labour: GES assumes no liability for loss, damage, or bodily injury arising out of Customer's supervision of GES provided labour. If GES CANADA supervises labour for a fee, GES CANADA shall be liable only for actions or claims arising out of its' negligent supervision. If Customer elects to use unsupervised labour, then Customer assumes all liability for the actions or claims that arise out of such work, and shall provide GES CANADA and show management with an indemnity, including defense costs, for any claims that result from Customers' supervision or failure to supervise assigned labour.

GES CANADA Terms & Conditions of Contract (Page 2 of 2)

GES CANADA TERMS AND CONDITIONS ARE
SUBJECT TO CHANGE AT GES' DISCRETION
WITHOUT NOTICE TO ANY PARTIES

7730 - 34th Street NW, Edmonton, AB T6B 3J6 Phone: 877.505.7767 Fax: 877.469.1619 www.gesexpo.ca edmonton@ges.com

Empty Storage: GES CANADA assumes no liability for loss or damage to Goods or crates, or the contents therein, while containers are in storage. It is the Customer's sole responsibility to affix the appropriate labels available at the GES CANADA Service Desk for empty container storage. Damage that is the direct result of GES CANADA's negligence shall be subject to the limitations of liability set forth in this document.

Forced Freight: GES CANADA shall not be liable for Goods not picked up by Customer's chosen carrier by the show deadline. It is the Customer's responsibility to complete accurate paperwork for shipping and ensure its' Goods are appropriately labeled. Customer acknowledges that it is a lessee of space, and as such has an obligation to remove its' Goods on or before the targeted time. If Goods remain on the floor after this point, GES CANADA has the right to remove them in order to restore the premises to its original condition for show management pursuant to the venue's lease with show management. In such cases GES CANADA is authorized to proceed in the manner chosen Customer on the Order for Material Handling Services/ Straight Bill of Lading. Failure to select on of the provided options will result in re-routing at GES CANADA's discretion, and at Customer's expense assuming the Goods are labeled for return. GES CANADA retains the right to dispose of Goods left on the show floor without liability if left unattended, left without labels or not correctly labeled.

Concealed Damage: GES CANADA shall not be liable for concealed loss or damage, uncrated Goods, or improperly package or labeled Goods.

Unattended Booth: GES CANADA shall not be liable for any loss or damage occurring while Goods are unattended in Customer's booth at any time, including, but not limited to, the time the Goods are delivered to the dock until the time the Goods are received by Customer's chosen carrier. All Material Handling Forms and/or Straight Bills of Lading covering outgoing Goods submitted to GES CANADA will be checked at the time of pickup from the booth and corrections to the count or condition will be documented where discrepancies exist.

Measure of Damage: GES CANADA's liability shall be limited to the lesser of 1) the depreciated value of Goods, 2) repair cost, or 3) the limitation of liability. The limitation of liability shall be \$0.30 (thirty cents) per pound per piece, \$50 (fifty dollars) per article or \$1000.00 (one thousand dollars) per shipment.

No Insurance: GES CANADA is not an insurance company and does not offer or provide insurance. It is the obligation of Customer to ensure Goods are insured at all times. Loss or theft of the Goods in storage or in transit to and from the show and or while on the show floor is the sole responsibility of Customer, unless it is shown that GES CANADA performed in a manner that constitutes gross negligence in the performance of its services for Customer.

Notice of loss or damage: In order to have a valid claim, notice of loss or damage to Goods must be given to GES CANADA within 24 hours of occurrence or delivery of Goods, whichever is later.

Filing of Claim: Any claim for loss or damage to Goods must be in writing, containing facts sufficient to identify the Goods, asserting liability for alleged loss or damage, and making claim for the payment of a specified or determinable amount of money. Such claim must be filed with the appropriate party within the time limits specified below.

Damage Reports, incident reports, inspection reports, notations of shortage or damage on freight bills or other documents, do not constitute filing of a claim.

Claim for goods alleged to be lost, stolen or damaged at the Show Site must be received in writing by GES CANADA within sixty (60) days after the close of the show.

Claims for Goods alleged to be lost or damaged during transit must be received by the responsible party within nine (9) months of the date of delivery of Goods. GES Logistics subcontracts the movement of Goods to third party carriers. Claims for damage in transit should be made directly with the Customer's carrier as shown on the Material Handling form / Straight Bill of Lading. In the event of a dispute with GES CANADA, Customer will not withhold payment or any amount due GES CANADA for Services as an offset against the amount of the alleged loss or damage. Customer agrees to pay GES CANADA prior to the close of the show for all such charges and further agrees that any claim Customer may have against GES CANADA shall be pursued independently by Customer as a separate action to be resolved on its own merits. GES CANADA reserves the right to pursue collection on amounts owed after show close, without regard to any amount alleged to be owed for damage, or loss.

Filing of Suit: Any action at law regarding loss or damage to Goods must be filed within one (1) years of the date of declaration of any part of a claim.

VII. Jurisdiction, Choice of Forum.

This Agreement shall be governed by and construed in accordance with the applicable laws of Canada or, alternatively, and depending on jurisdiction, the laws of the Province of Alberta.

VIII. Advance Warehousing / Temporary Storage / Long Term Storage.

All terms and conditions relative to Advanced Warehousing / Temporary Storage / Long Term Storage are contained in the separate agreement entitled "Storage Agreement". In the event that a Storage Agreement is not executed between the parties, the following shall apply with respect to GES CANADA's liability for Customer's Goods:

The responsibility of GES CANADA with respect to Exhibit Material is limited to the exercise of ordinary care and diligence in handling and storing of Customer's Goods. GES CANADA shall be liable only for loss or damage to Goods caused by GES CANADA's sole negligence. GES CANADA's liability is limited to sixty (\$0.60) cents per pound or the actual cash value per article. In the case of partial loss or damage, the maximum liability shall be prorated based on weight. GES CANADA is not responsible for any loss or damage to Goods caused by, but not limited to fire, theft, the elements, vandalism, moisture, vermin, mechanical breakdown or failure, freezing or changes in temperature, as well as any other causes beyond GES CANADA's immediate control. GES CANADA is not responsible for the marring, scratching, or breakage of glass or other fragile items. GES CANADA is not liable for the mechanical functions of instruments or appliances even if such articles are packed or unpacked by GES CANADA. In no event shall GES CANADA be liable for special, incidental, indirect, or consequential damages, including business loss of any kind, resulting from any damage to or loss of Goods or from any act or failure to act. Customer pays storage fees, if any or costs for advance warehousing for use of the space only. There is no guarantee of security or representations made by GES CANADA as to appropriateness of the conditions for Exhibitors' Material. This risk of loss remains the Customer's alone and GES CANADA recommends the Customer carry and maintain insurance in amounts sufficient to cover its risk.

SPECIAL NOTE: THE CONSIGNMENT OR DELIVERY OF A SHIPMENT TO GES CANADA OR ITS SUBCONTRACTORS BY A CUSTOMER OR BY ANY SHIPPER ON BEHALF OF THE CUSTOMER SHALL BE CONSTRUED AS AN ACCEPTANCE BY SUCH EXHIBITOR (AND/OR OTHER SHIPPER) OF THE TERMS AND CONDITIONS SET FORTH IN THIS AGREEMENT.

Safety First!

7730 - 34th Street NW, Edmonton, AB T6B 3J6 Phone: 877.505.7767 Fax: 877.469.1619 www.gesexpo.ca edmonton@ges.com

Safety is very important for everyone working in the exhibit hall - especially you!

GES CANADA is committed to safety throughout our company and in the work that we do. We request that you make safety a part of your activities during the show. If you see something unsafe or that presents a hazard, please bring it to the attention of a GES CANADA supervisor. By reporting unsafe or hazardous conditions, you will help make the show safer and more enjoyable for yourself and your fellow exhibitors.

Below you will find a list of Loss Prevention Guidelines that we request you follow while at showsite. These Guidelines will enhance the overall safety of the show and help to prevent injuries to you, our employees, and other exhibitors. Enjoy the show and do it safely. Thank you for your Cooperation!

Exhibitor loss prevention guidelines at showsite

- Smoking is prohibited in the exhibit hall. Please be sure all cigarettes are fully extinguished.
- Standing on chairs, tables, and other furniture is PROHIBITED. The furniture is not designed to support your standing weight. Please use a ladder or ask GES personnel for assistance.
- Forklifts and pallet jacks are to be used by authorized GES CANADA personnel only. Please do not operate this equipment. Ask for help.
- Be aware of the forklifts moving throughout the aisles and docks. Please stay clear of them, especially when they are carrying a crate or a load.
- Never run in the exhibit hall. Please walk. Watch your step in the aisles and stay away from the loading docks.
- Electrical wires and cords can be hazardous if frayed or stretched over a walkway. Please check all cords for damage. Notify the electrical service company if you need assistance repairing or removing a damaged cord. Do not overload outlets or plugs.
- Please keep fire exits clear. Report any fires immediately or pull the nearest fire alarm.
- If you spill something, or notice a spill, clean it up or report it immediately. Please do not walk away from a spill.
- Use good housekeeping. Dispose of waste properly and keep materials stacked securely.
- Keep aisles free and clear of any and all debris.
- Protect your valuables while on the show floor. Please keep all expensive or valuable items secured. Unattended items in booths are easy theft targets.
- Notify a GES CANADA representative of any safety issues or concerns.