

President's Message

In my first column, I reported that I thought I'd done two smart things in my life. One was to join the IEEE and work it hard, and the second was to get involved at my university with a team entering in the World Solar Challenge, the race for solar powered cars across Australia, in 1987. So this time for the fun stuff, a few thoughts about such competitions. I admit to a lifetime as a dedicated educator, with sufficient passion to think that even if you don't have daily contact with students, it is the responsibility of all power electronics engineers, as it is for engineers in general, to give very serious attention to, and provide input to the education process. Believe me, it really doesn't work if the academic alone decides what, and how, an engineering student should be taught. It's the people in the field who see, on a day-to-day basis, what are the real needs of a practicing engineer. Well that's my excuse for discussing an education issue in detail with the entire membership.



There is a substantial body of us educators who see very real value in such projects. Mind you, many academics are a bit nervous about them. Your ability to actually do engineering, and to teach about the successful and timely completion of challenging engineering projects is very publicly exposed. If a student team fails to compete credibly, it is hard to blame that entirely on the students. In fact most of us would observe that the abilities of students, ranging from the best to the worst, are pretty consistent regardless of institutional size, geographical location etc.

Now here's a reasonably well-kept secret. The easiest thing for an academic to do is to teach a course in which assessment is by examination and assignments, involving lots of calculations that can be graded as right or wrong. The worst kind of teaching just teaches how to get the problems at the end of the chapter right. Richard Feynman savagely attacked this kind of teaching in his "Surely You're Joking Mr. Feynman".

At the highest level of the Ph D, the
Continued on page 5

Invitation to PESC® '03 in Acapulco, Mexico

It is my great pleasure to invite you to the 34th IEEE Power Electronics Specialists Conference, PESC'03, to be held June 15—19, 2003 at the Hyatt Regency Acapulco Hotel, in Acapulco, Mexico, the most famous tourist resort in the Mexican Pacific coast.

The local organizing committee, composed by enthusiastic volunteers from CENIDET and the IEEE Section Morelos-Power Electronics Chapter, is working very hard to finalize details of the logistics and technical program. All the necessary ingredients are in place to have a memorable event. See the flyer in this *Newsletter*, or for the latest details visit <http://www.pesc03.org>.

The technical program will have (including 80 posters) 328 papers—carefully selected from 635 digests, thanks to the excellent work of 240 international members

of the technical committee—as well as 4 tutorials and 2 rap sessions which respond to the survey taken at PESC'02.

During the three major events of the conference social program (welcome reception, banquet, and awards luncheon), you will have the opportunity to taste traditional Mexican food and drinks, and to enjoy Mexican music and folkloric groups, accompanied, of course, with the traditional "mariachi."

PESC'03 attendees can also enjoy an enormous variety of Acapulco attractions.



You can select from the 20 beaches that Acapulco bay has to offer, the vibrant and diverse nightlife, or a great variety of water sports. Of course you cannot leave Acapulco

without seeing "La Quebrada Divers" show, the most famous attraction of the port, which has been astounding visitors since 1934.

See you in Acapulco.

Jaime Arau

General Chair, PESC 2003

Major Society Awards to be Presented at PESC®

Awards presentations this year will take place at the Awards Luncheon on Thursday, 19 June 2003, in Acapulco, Mexico at PESC® 2003. Our Society's most prestigious award, the William E. Newell Power Electronics Award, will be presented for the twenty-seventh year. The PEELS Distinguished Service Award and the Richard M. Bass Outstanding Young Power Electronics Engineer Award will be presented for the seventh year. The PEELS Best Chapter Award will be presented for the fourth year. The Society will also present the PEELS Transactions Prize Paper Awards to the authors of the three papers judged by the Associate Editors to be the best papers published in the PEELS Transactions in 2002.

The ceremonies will also recognize members of PEELS who were elected to Fellow Grade effective 1 January 2003.

A ticket for the Awards Luncheon is included in the full registration fee for IEEE members and non-members. Persons registering at student rates and partner rates may purchase tickets for the luncheon. Online registration is available at <http://www.pesc03.org/>.

Chris Riddleberger

Chair, PEELS Awards Committee

In This Issue

President's Message	1
PESC® '03 Invitation / Flyer	1,4
Society Awards	1
Joseph J. Suozzi Mourned	3
IEMDC Invitation	3
Society Appointments	5
Rashid wins Achievement Award	6
Chapter News	6
European Liaison	6
Microprocessor Power	7
MDMPEC '03	8
APEC® '03 Recap / Photos	9,15
AdCom Meeting Highlights	9
Director's Message	9
For Quicker News Delivery	9
Call for Technical Articles	10
Book Review: Electric Drives	11
PESC '08 Call for Proposals	11
Power Electronics Tutorial CD	12
SDEMPED Diagnostics Symp.	13
INTELEC® '03 Invitation	13
PELS Shirt	13
Micromouse Contest Results	14
Meetings of Interest	16

DOUBLE CURRENT DENSITY FOR DC-DC CONVERTERS WITH DirectFET™ MOSFETs

Direct Chip Attach Slashes Thermal and Electrical Resistance

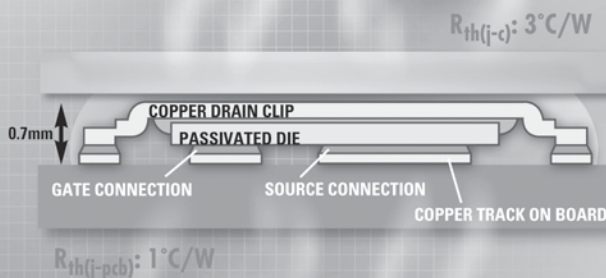

2-Phase Buck Converter, 2 MOSFETs per Phase, 1U VRM
with 425 LFM Airflow, 12V_{IN}, 1.7V_{OUT}, 2MHz

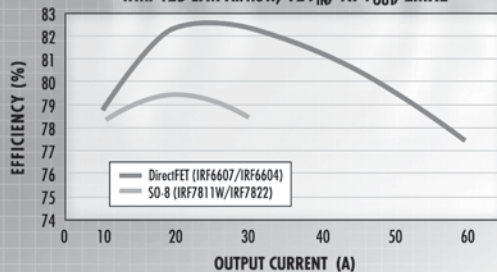

REGISTER FOR EMAIL NEWS BUY ONLINE

Today's advanced processors demand trail blazing power management solutions. Look no further than IR's DirectFET MOSFETs to advance your next high frequency, high current DC-DC converter design.

DirectFET's proprietary packaging technology delivers a surface mount MOSFET especially honed for heatsinks to double the current density (A/in²) of a typical SO-8 design slashing part count, shrinking board space, and lowering system cost.

Proprietary Package Design *(patents pending)*

DirectFET's package, the first of its kind, built specifically for power from the ground up, uses an innovative die passivation to reduce package restrictions and enable top-side cooling to dissipate heat away from the PCB. In combination with improved bottom side cooling, this technique plunges thermal and electrical resistance to depths never before achieved for this form factor.

The DirectFET family of products includes IRF6601, IRF6602, IRF6603, IRF6604 and IRF6607.

Key Advantages Over SO-8

- Double current density (A/in²)
- Up to 50°C cooler at same current level
- The lowest thermal resistance
- 90% less package resistance (0.1mΩ)
- 20% lower system cost, typ.
- The lowest package profile at 0.7mm
- Compatible with existing high volume assembly processes

Choose IR's trail-blazing DirectFET MOSFET to keep your next hot design running cool.

for more information call 1.800.981.8699 or visit us at
<http://directfet.irf.com/if>

International
IR Rectifier
THE POWER MANAGEMENT EXPERTS

INTELEC® Founder J. J. Suozzi Mourned

IEEE Fellow Joseph Suozzi, co-founder and a long-time leader of the PELS-sponsored IEEE International Telecommunications Energy Conference (INTELEC), died of complications following surgery on 28 January 2003 at age 76. His wife of 50 years, Angeline Suozzi, five daughters, six grandchildren, and his brother and his sister survive him.

Dr. Suozzi served in the U.S. Navy during World War II. He then earned BEE and MEE degrees from Catholic University in Washington, DC, and the PhD degree from Carnegie-Mellon University in Pittsburgh, PA. After teaching electrical engineering at Catholic University and working in applied

magnetics at the Naval Ordnance Laboratory in Silver Spring, MD, he spent 33 years at Bell Telephone Laboratories, retiring from AT&T Bell Labs in 1989 as Director of the Electronic Power Systems Laboratory. During his career, he authored or co-authored ten technical papers on magnetics and telecommunications power and received four patents on magnetics.



In the IEEE Magnetics Society, Dr. Suozzi held a number of leadership positions, including two years as president of the predecessor organization, editor of the IEEE

Transactions on Magnetics, and general chair of three IEEE INTERMAG conferences.

In 1975, with N. Osifchin and B. J. Yokelson of Bell Labs, Dr. Suozzi began planning for a new conference focused on power for telecommunications systems. He was the general chair of the first INTELEC in Washington, DC in 1978, wrote the constitution and bylaws for INTELEC, and was the first chair of the Conference Executive Committee. He was an active member of this committee and the Advisory Committee until his death.

There was not yet a Power Electronics Society when INTELEC was started, so Dr. Suozzi obtained IEEE sponsorship from the IEEE Communications Society. After PELS was formed, he represented INTELEC in negotiations with PELS, COMSOC, and IEEE staff and volunteers. These negotiations resulted in an agreement to transfer INTELEC sponsorship from COMSOC to PELS in 1991, where INTELEC joined PESC® and APEC® to present the results of work in the ever more important field of power electronics to its practitioners. Dr. Suozzi was also instrumental in establishing the Telecommunications Energy Special Conference (TELESCON®), a smaller conference covering topics similar to those of INTELEC.

Along with his work on society-sponsored activities, he has served on the IEEE Technical Activities Board and was its Finance Chair in 1973 and 1974. He was Chair of the North Jersey Section Awards Committee from 1983 to 1987.

To honor Dr. Suozzi, INTELEC plans to name its annual fellowship in power electronics in his memory.

Invitation to IEMDC in Madison WI

It is my joyful task to invite you to come join us in beautiful Madison, Wisconsin, for the IEEE International Electric Machines and Drives Conference (IEMDC), June 1-4, 2003. The IEMDC is the only conference in North America devoted entirely to electric machines and drives technology and this year's conference promises to be the best ever. This is the fourth IEMDC, a gathering held every two years, which is rapidly becoming the premier conference for electrical machine technology worldwide. The conference is co-sponsored by the IEEE Power Engineering, Power Electronics, Industrial Electronics, and Industry Applications Societies with cooperating support from the IEE (London).

This year's conference will be held at the Monona Terrace Community and Convention Center, a magnificent five-level lakeside facility originally designed by world renowned architect Frank Lloyd Wright. Madison itself is a progressive, cosmopolitan city of 210,000 and is home to the world-class University of Wisconsin and the seat of state government. With four lakes and over 200 parks, Madison is one of the most scenic cities in the United States.

The response to the Call for Papers was overwhelming with 461 digests having been received. After thorough reviews, the Program Committee accepted 319 papers for presentation in both oral and poster sessions. This number reveals an increase of over 80% compared to the last IEMDC conference. The schedule includes special multiple sessions on the subjects of large turbogenerators, automotive applications, and aerospace applications of machines and drives. Four interesting plenary session papers are scheduled and an exhibition featuring software, components, and equipment is planned. Additional activities include several technical tutorials on Sunday June 1, a variety of spousal tours during the week, and a technical tour after the conference.

If you are involved in the design, operation, or application of electrical machines and/or drives, you can not afford to miss this conference! Further information can be found on the website <http://www.iemdc03.org>. I sincerely hope you will be able to attend.

Tom Lipo
Univ. of Wisconsin
IEMDC 2003 Conference Chair
lipo@engr.wisc.edu

IEEE Power Electronics Society Officers

Dean Patterson, President
Ron Harley, V. P., Operations
F. Dong Tan, V. P., Meetings
Steven B. Leeb, Treasurer

<http://www.pels.org>

The IEEE Power Electronics Society Newsletter (ISSN 1054-7231) is published quarterly by the IEEE Power Electronics Society of the Institute of Electrical and Electronics Engineers, Inc. Headquarters: 3 Park Avenue, 17th Floor, NY 10016-5997. \$1.00 per member per year (included in Society fee) for each member of the Power Electronics Society. Postmaster: Send address changes to IEEE POWER ELECTRONICS SOCIETY NEWSLETTER, IEEE, 445 Hoes Lane, Piscataway, NJ 08855-1331.

News items should be sent to: Gene Wester, Editor, *PELS Newsletter*, Jet Propulsion Laboratory, M/S 303-300, 4800 Oak Grove Drive, Pasadena, CA 91109-8099, USA; TEL: +1 818 354 3489; FAX: +1 818 393 4272; EMAIL: pelsnews@ieee.org. Deadlines for copy are March 15, June 15, September 15 and December 15. Submission of items by email in plain-text format is preferred. Plain-text (straight ASCII) submissions on 3.5" diskettes are welcome, and should be accompanied by a backup printout. Fax submissions are acceptable, but are least desirable. Full-page calls for papers and announcements of PELS-sponsored conferences are welcome and should be sent as both high-quality hard copy and RTF format file.

The editor gratefully acknowledges the Jet Propulsion Laboratory for significant support of his editorial activities.

©2003 IEEE. Permission to copy without fee all or part of any material without a copyright notice is granted provided that the copies are not made or distributed for direct commercial advantage, and the title of the publication and its date appear on each copy. To copy material with a copyright notice requires special permission. Please direct all inquiries or requests to the IEEE Intellectual Property Rights Manager, TEL: +1 732 562 3966, FAX: +1 732 981 8062, EMAIL: copyrights@ieee.org.

Periodicals Postage paid at New York NY and at additional mailing offices.

PRINTED IN THE U.S.A.

CONFERENCE ANNOUNCEMENT*for the 34th Annual***Power Electronics Specialists Conference****June 15 – 19, 2003****Hotel Hyatt Regency Acapulco
Acapulco, Mexico**Website: <http://www.pesc03.org/>Email: secretariat@pesc03.org

CENIDET (National Center for Research and Technological Development) and the IEEE Morelos Section are proud to host PESC'03 in the world-renown port of Acapulco, Mexico.

PESC is one of the most important forums in the world for discussing the latest advances and research subjects in power electronics.

- Technical program with 328 papers (including 80 posters)
- Four professional and educational tutorials:
 - (1) Power Electronics Control of De-regulated Power Systems
 - (2) Voltage Source Converters for Dc-Grid Wind Farm Applications
 - (3) Power Quality: The Big Challenge of Electrical Engineers in the New Century
 - (4) New Ways of Teaching Power Electronics and Electrical Drives
- Two rap session topics:
 - (1) Permanent Magnet Machines – A Renaissance
 - (2) Supplying Low Power/Mobile Processors
- Traditional conference events (Reception, Gala dinner, Awards luncheon, etc).

Location

Acapulco is the largest and most spectacular tourist resort on the Mexican Pacific. As a result of its stunning beaches, exuberant natural surroundings and wonderful climate, this port has been dubbed the Pearl of the Pacific. It is the most popular holiday resort in Mexico and Latin America, since its functional and modern infrastructure has had very little impact on its original beauty and attractions. PESC'03 website provides details about the conference, travel, lodging, dining, etc.

PESC'03 Conference Secretariat

Electronics Department – CENIDET

Interior Internado Palmira s/n, 62490 Cuernavaca, Morelos, Mexico

Phone: +52 (777) 318 7741 (Ext 158) Fax: +52 (777) 312 2314

PESC'03 is organized and sponsored by the IEEE Power Electronics Society.

President's Message *from page 1*
thesis is a work by a single individual. We stress the fact that it has to be done by one person. As soon as we go out into the real world, employers require us to work as teams. The classical education does very little to teach teamwork to students. It's hard to organize, and the toughest thing is how to grade all the team members who submit a single piece of hardware and a document. We know that some do more and better work than others but it's hard to quantify that into grades, and so we fall back to the individual test, or working standard problems.

There are still more difficulties in such group projects. I'm often invited to speak to a group who has expressed interest in maybe having a go at solar car racing.

I always tell them that I can guarantee them a place in the top quarter of the field, if they will only do the following three simple things:

1. Take my advice, freely given, about a format, layout, whose body shape to copy, which tires to use, etc. (really simple stuff)
2. Actually believe all the things their high school physics teachers taught them. It's astounding how often those simple calculations of force on an inclined plane, potential energy, etc. are pushed to the back of the mind, lost in discussions about aesthetics. You don't even need acceleration and kinetic energy equations, but you do need two simple equations, one for rolling loss and one for aerodynamic loss, which I also give them.

3. Finish the car BEFORE the race starts. That's the biggie and it gets the 75% you are going to beat.

It's actually endemic. The only people who voluntarily get involved in such unstructured and open ended activities, where so little is fully understood when you start, have to be the optimists of the world. The realists and the pessimists get some reasonable idea of the magnitude of the task, the likely problems, the dangers of starting before having anything like adequate funding in place, and very quickly walk away.

That's the problem. You are left only with optimists, who pathologically are incapable of realistically and accurately estimating how long any single job will take them. So when every dependent task bar on the Gant chart is stretched a little because of optimism, the team finishes the car maybe by the end of the third or fourth day of racing. Its salutary to ask people at the start line how many actual road miles of trialing, in its close to final form, their vehicle has

Society Appointments

PELS President Dean Patterson has announced the following appointments to leadership roles in Society activities:

Administrative Committees

Awards	Chris Riddleberger <c.riddleberger@ieee.org>
Books, IEEE Press	Bill Hazen <blhpp@rcn.com>
Chapter Development	Vassilios Agelidis <v.agelidis@elec.gla.ac.uk>
Constitution/Bylaws	Ron Hui <eronhui@cityu.edu.hk>
Educational Activities	Leon Tolbert <tolbert@tennessee.edu>
Electronic Letters	Philip Krein <p.krein@ieee.org>
Fellows Evaluation	Tom Habetler <thabetler@ece.gatech.edu>
History	Keyue Smedley <smedley@ece.uci.edu>
Intelligent Transportation, TAB	Dean Patterson <patterson@ieee.org>
Liaison, Asian	Tatsuo Sakai <sakai.tatsuo@lab.ntt.co.jp>
Liaison, European	Bruno Allard <allard@cegely.insa-lyon.fr>
Liaison, Intersociety	Marcel Simoes <mgsimoes@ieee.org>
Liaison, So. America	Miguel Velez-Reyes <m.velez@ieee.org>
Membership/Publicity	Enrico Santi <santi@engr.sc.edu>
Newsletter Editor-in-Chief	Gene Wester <pelsnews@ieee.org>
Newsletter Associate Editor	Juan Balda <jbalda@uark.edu>
Publications	Alex Stankovic <astankov@ece.neu.edu>
Standards	Jason Lai <laijs@vt.edu>
Transactions Editor-in-Chief	Daan van Wyk <peleditor@ieee.org>
Treasurer	Steve Leeb <sbleeb@mit.edu>
Webmaster	Grahame Holmes <web@pels.org>

Technical Committees

Automotive Power Electronics	John Shen <johnshen@umich.edu>
Dc Power Supply	Jose Cobos <cobos@upmdie.upm.es>
Electronic Transformers	Bill Goethe
Motor Drives	Alfio Consoli <aconsoli@diees.unict.it>
Power Packaging	Doug Hopkins <d.hopkins@ieee.org>
Rectifiers and Inverters	Fang Peng <fzpeng@egr.msu.edu>
Simulation, Modeling, Control	Antonello Monti <monti@engr.sc.edu>

Conference Steering Committees

APEC	Tom Wilson, Jr. <twilson@transim.com>
IEMDC	Dong Tan <dong.tan@ieee.org>
INTELEC	Philip Krein <p.krein@ieee.org>
PESC	K. Yotsumoto <yotsumoto@ntt-bti.co.jp>
	Mark Jacobs <jacobs@ieee.org>
	Ger Hurley <ger.hurley@nuigalway.ie>

For a complete roster of elected and appointed positions in the Power Electronics Society, click the "Committees and technical activities" link at www.pels.org.

Bob Myers
PELS Executive Director
bob.myers@ieee.org

had.

But on the way these young people learn a huge amount about cooperation, teamwork, reliance on others, interdisciplinary compromises, and the fascinating interface between the real world of practical systems and the academic world of theory. When speaking to primary school children about the solar car I ask if they have ever heard their parents say "it's all very well in theory, but it's not like that in practice". A sea of little hands goes up. I then wickedly tell them that the next time they hear that they should tell their parents that Dr. Patterson

says they should go away and get their theory right.

So what's this all got to do with the Power Electronics Society of the IEEE? Well your society is actively, financially, and administratively involved in a competition of this type called the "International Future Energy Challenge" (see <http://www.energychallenge.org>).

The first challenge, to develop an economic inverter for a domestic fuel cell system, was run in 2000/2001, was limited to USA Universities, and was a huge learning

Continued on page 10

Rashid wins Meritorious Achievement Award

PELS member Muhammad Harunur Rashid has been honored with the 2002 IEEE Educational Activities Board (EAB) Meritorious Achievement Award in Continuing Education. On 16 October during the IEEE Industry Applications Society (IAS) Annual Conference in Pittsburgh, PA, IEEE Vice President for EAB Lyle Feisel presented the award to Dr. Rashid "for contributions to the design and delivery of continuing education in power electronics and computer-aided-simulation."



This international award was established in 1984 by the EAB to provide an opportunity for colleagues to recognize dedicated contributions in the areas of design, delivery and support of continuing education courses and programs.

In the last decade, Dr. Rashid has given more than 30 invited lectures and short courses from Dhaka, Bangladesh to Perth, Australia to Indiana, USA. "Technology reinvents itself every six to 12 months, and waits for no one," he said. "Those who keep up and constantly seek to expand their horizons — in whatever their field — will have the best chances of getting ahead, working on their own, and switching careers whenever they choose. This is very true for engineering and technology."

Putting yet another educational tool in the hands of practicing engineers, he has also written self-study courses published by the peer-reviewed IEEE Press. Dr. Rashid is an internationally respected researcher and author of books on power electronics, including the well-received "Power Electronics Using SPICE" (Simulation Program for Integrated Circuit Emphasis). His books have been published in both North American and International Editions and have been widely adopted by universities from the US to Korea.

"Continuing education is like watering plants to save their life; it brings vitality and new dimension to one's professional life," Dr. Rashid said when asked about his commitment to continuing education. "Without it, an engineer or technologist could be 'professionally dead' within few years after graduation. We, the engineers like any other professionals, all strive to learn new things continually and survive in the changing glo-

bal market place. Continuing education can play a key role."

Dr. Rashid is currently a professor at the University of Florida (UF) and the Director of the UF/UWF (University of Western Florida) Joint program. He is a Distinguished Lecturer and Speaker of the IEEE-IAS, an IEEE and an IEE (UK) Fellow, a licensed Chartered Engineer (UK) and a Professional Engineer (Canada). He was awarded his Ph.D from the University of Birmingham (UK).

*Lynn Murison
Outreach Administrator
IEEE Educational Activities Board*

German Chapter Celebrates Five Years

The Joint IEEE Industry Applications Society, Power Electronics Society and Industrial Electronics Society (IAS/PELS/IES) German Chapter originated from the IEEE-IAS German Chapter, which was founded December 18, 1997. Founding chairman was Prof. De Doncker (Aachen University of Technology), vice chair Prof. Schröder (Munich University of Technology). To strengthen our Chapter activities, merging with the PELS and IES into one German Chapter was desirable. This has proved to be judicious because all three societies are active in the areas of drives, power electronic devices and converters. The Joint IAS/PELS Chapter was approved March 12, 1999 and the Joint IAS/PELS/IES Chapter on February 28, 2001. The Chapter received the "IEEE PELS Best Chapter Award for 2001."

At present, our Chapter has 333 members. Since the last election in November 2002, the Chapter has been five officers: Dr. Magyar (chair, D-Tech GmbH), Prof. Petzoldt (vice chair, TU Ilmenau), Dr. Hahn (secretary, Bosch Rexroth AG), Dr. Bakran (treasurer, Siemens AG) and Dr. Lelkes (publicity/membership, PMDM Precision Motors Deutsche Minebea GmbH).

The main activity of the Chapter is to hold three meetings annually. We had many guest lecturers: Prof. Hirofumi Akagi from Japan; Prof. Robert D. Lorenz, Prof. Mehrdad Ehsani and Caio A. Ferreira from the US; Prof. Gyula Retter from Hungary; Dr. Somboon Sangwongwanich from Thailand. The last chapter meeting was held in Stuttgart, together with the Robert Bosch GmbH. On the first day, the 96 participants heard lectures about topical questions of regenerative energy production (Prof. Leonhard, TU Braunschweig), of efficiency

test of induction motors (Prof. Müller, TU Dresden), and about the new, generalized definition of reactive power (Prof. Späth, Univ. Karlsruhe). As our guest, Prof. Chattopadhyay (IEEE-IAS Calcutta Chair) held a lecture about the past, present and future of power electronics. The official part of the meeting was followed with a pleasant dinner.

On the second day, the host company presented lectures about its current research and development projects in the field of motors and drives for automotive applications. In three groups, the participants took part in interesting company tours, where we could see in practice the R&D activities of the Robert Bosch GmbH. The successful meeting concluded with a comprehensive technology review by Prof. Chattopadhyay about high-performance industrial ac drives.

The next meeting will be at Infineon Technologies AG in Regensburg. Guests are welcome. For more information, please visit our website at www.ieee.org/r8/germany/ias-pels

*András Lelkes
Chapter Publicity/Membership
lelkes@ieee.org*

European Liaison

Effective March 1, Bruno Allard became the European Liaison for PELS. The European Liaison serves as the interface between PELS and the European power-electronics societies (mainly EPE, ESPC), universities, industry, and potential authors for society conferences. I heartily thank Rik DeDoncker, past European Liaison, for initiating solid contacts with EPE Executive Council and Joint IAS-PELS Chapters in Europe. I propose to explore stronger international cooperation between PELS, with its IEEE sister societies (i.e. IAS, IES and PES), and European associations and societies. It is anticipated that cooperation will ultimately lead to improved quality of our products, e.g. conferences. I invite the cooperation of European IEEE officers and society chairs to share fruitful information.



*Bruno Allard
PELS European Liaison
CEGELY, INSA Lyon, France
Tel: +33 4 72438177
FAX: +33 4 72438530
allard@cegely.insa-lyon.fr*

Meeting the Power Challenge of Microprocessors[®]

Dr. Alex Lidow
Chief Executive Officer

International Rectifier Corporation
El Segundo, CA 90245

In addition to death and taxes, another truth remains a certainty as we stand at tomorrow's doorstep. Advanced microprocessors will continue to grow more powerful—demanding more from the devices that power them. In order to maintain manageable levels of power dissipation, operating voltages must continue to decrease as currents ratchet upward. At the same time, the negative attributes common to extremely high currents such as great variations in current (di/dt) and the increasingly difficult task of voltage regulation must be dealt with effectively.

In 2005, it's projected that converters that power advanced microprocessors will run at an operating frequency of 2 MHz and deliver 130 A at 1.1 V. An even greater challenge awaits in meeting their maximum tolerance for regulation of ± 25 mV with di/dt of 800 A/ μ s, a requirement about 10 times more demanding than the spec of five years ago.

These ultra-fast microprocessors will demand a shift in power converter design requiring innovative control architectures capable of delivering power through synchronous buck converters with multiple-

phase topologies. There are many possible approaches to this power management challenge, all varying in their ability to scale with the ever-changing needs of the microprocessor.

One approach is to integrate the driver and controller ICs into a single chip. While this lowers part count and reduces cost, it increases board design complexity. Trace lengths are hard to minimize between the driver and MOSFETs, boosting parasitics and limiting switching frequency. Also, the controller IC will suffer from the heat and noise of the driver. Worse yet, the maximum number of phases that can be accommodated becomes fixed by the controller IC that is chosen, with cascading controller designs adding yet another layer of cost and complexity.

Another option is to separate the driver ICs from the controller. This simplifies board design and shortens traces from the drivers to the MOSFETs, allowing for higher frequency operation. Yet, the number of phases remains fixed, and current sensing must travel through a long interconnect trace causing delays and increasing complexity.

A solution that overcomes all of these

shortcomings and can scale with the ever-growing needs of tomorrow's microprocessor is a design that repartitions the work between the controller and driver ICs at the silicon level, as shown in Fig. 1. The controller can be dedicated to the functions occurring only once in a multiphase design—such as programmable voltage identification circuitry, a PWM ramp oscillator, an error amplifier, bias voltage, and fault detection. The driver IC, now best described in its elevated role as a *Phase IC*, could concentrate on functions that repeat in each of the phases in the design. These functions include current share, PWM, phase timing, current sense and dual-gate driver. Best of all, this design would allow for a flexible number of phases that would communicate through a 5-wire bus.

The result is a truly scalable design path for multiphase synchronous buck converters capable of delivering power in one to any number of phases. Eliminated are the driver noise and heat into the controller, the long traces limiting frequency and performance, and board layout complexity. No silicon sits idle to impede performance or

Continued on page 10

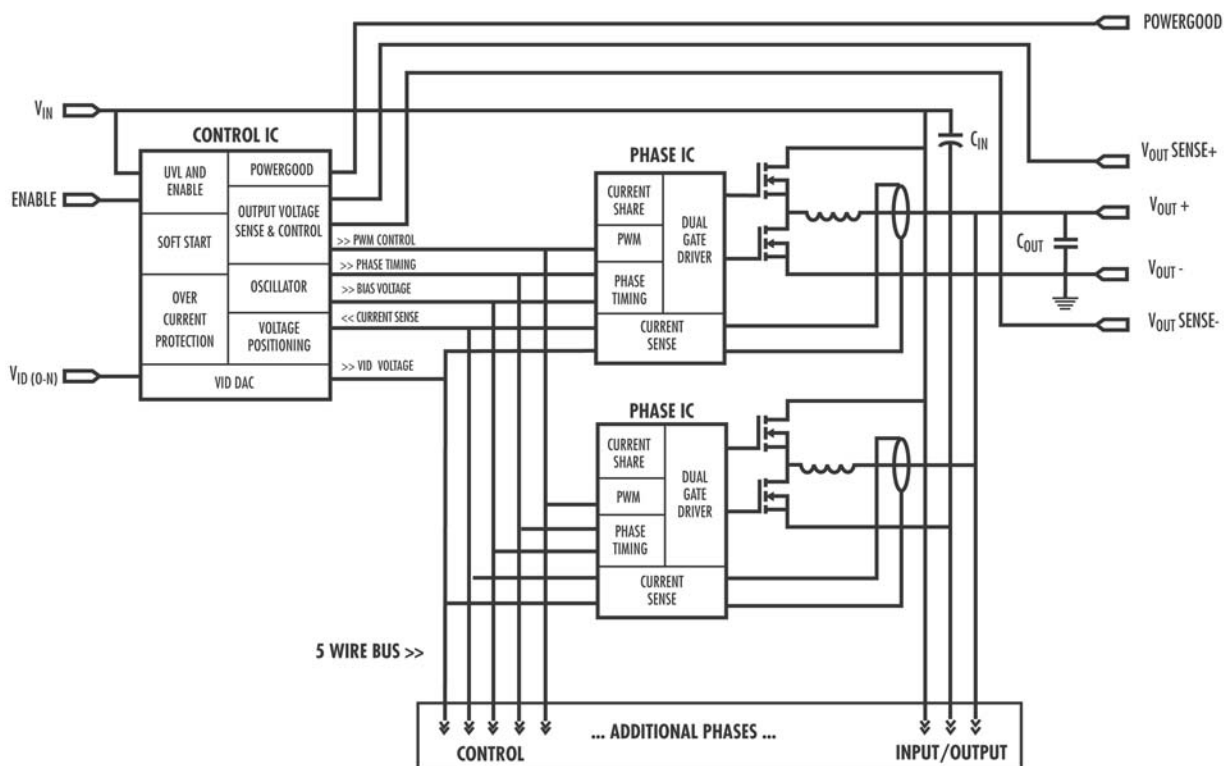

Figure 1. Scalable Multiphase Architecture



Announcing a Workshop on MULTIMEDIA DELIVERY OF MODERN POWER ELECTRONICS CURRICULUM

September 3-5, 2003

University of Salerno, Italy

<http://www.mdmpec03.unisa.it>



The University of Salerno, the University of Central Florida, and the IEEE Power Electronics Society are sponsoring a workshop to discuss educational issues related to teaching power electronics. The objective of this workshop is to assess current multimedia efforts and explore new means to develop multimedia-based instruction in the area of power electronics. The workshop will discuss various methods and delivery technologies available and how to implement them into power electronics courses. Moreover, the workshop will focus on detailed course offerings, at both undergraduate and graduate levels, and will explore the current industry needs for power electronics engineers. The workshop will provide the opportunity to make use of the collective experiences of many experts in the field in regard to using the web technology in education.

The workshop will focus on the following Topics:

1. *Methods and tools for multimedia education and e-Learning.*
2. *Web-based delivery environments.*
3. *Hardware and software laboratory support.*
4. *Multimedia enhancement tools for power electronics*
5. *Innovative industry-university partnerships in power electronics education.*
6. *Multidisciplinary team projects in power electronics (in the Future Energy Challenge Kickoff).*

Other related topics are welcome.

The Workshop is organized with the aim of widening the perspective of the discussion on topics related to Power Electronics education and stimulating interactions between universities and industries of the two continents that are developing and experimenting multimedia and e-learning technologies. Contributions focusing on learning content management and education methods are strongly encouraged.

Workshop Participation

The workshop is open to participants from academia and industry. See the website above for more information. If you are interested in attending or participating, please contact the person designated below for your country and topic.

Participants From Europe And Other Countries:

Topics 1 to 3: Prof. Massimo De Santo, Tel.+39 089 964276, email: desanto@unisa.it

Topics 4 to 6: Prof. Nicola Femia, Tel.+39 089 964160, email: femia@unisa.it

Dipartimento di Ingegneria dell'Informazione ed Ingegneria Elettrica, Università di Salerno,
Via Ponte Don Melillo, I-84084 Fisciano (SA), Italy

Participants From The USA:

Topics 1 to 6: Prof. Issa Batarseh, email: batarseh@mail.ucf.edu

School of Electrical Engineering and Computer Science, University of Central Florida, Orlando, FL 32816

Deadlines:

June 20, 2003

Three-page digest due

July 20, 2003

Authors notified of digest acceptance

August 20, 2003

Final paper due, six-page maximum

We look forward to welcoming you to Salerno for MDMPEC 2003.

APEC® 2003 Recap

APEC 2003 was held February 9–13, 2003, at the world famous Fontainebleau Hilton in Miami Beach, Florida. The Fontainebleau has been the site of several famous movies including James Bond's "Goldfinger," the "Bellboy" with Jerry Lewis, the "Bodyguard" starring Whitney Houston and Kevin Cosner to "Ali" featuring Will Smith.

For the third consecutive year the Exhibition had a record number (154) of booths—in spite of heightened terrorist threat advisory levels. Jorge Mare, Marketing Manager of Elcon Products, discussed their decision to exhibit at APEC. He said "APEC is a great show for us. It provides a high profile audience for the type of people we want to talk to—it's very focused." Jorge's comments on our "high profile audience" were echoed at a Power Sources Manufacturers Association Meeting by Rich Hammon, V.P. Research and Development, Astec. Active in the design of switching power supplies since 1971, Rich was a candidate for a seat on PSMA's Board of Directors. He stated that "being in the presence of some of you is like being in the Super Bowl," a reference to all the technical talent in attendance.

You will find a "Who's Who" of applied power electronics at APEC. At one of the sessions, Dr. Trey Burns, V.P. Worldwide Technology, Artesyn Technologies, engaged in open-mike discussion with a speaker at the end of his presentation. Prior to serving as General Chair of APEC 3 & 4 (in 1988 and 1989), Trey served as president of the IEEE Council on Power Electronics which preceded PELS. You simply cannot place a value on APEC networking opportunities.

Continued on page 15

Quicker News Delivery

The *Power Electronics Society Newsletter* is available on the internet in PDF format approximately three weeks sooner than hardcopies can be printed, labeled, and delivered by postal mail. To receive email notification when the newsletter is posted on the PELS server, go to <http://www.pels.org/Mailing/MailForm.html> and add your email address to the notification list. Additionally, the email notification sometimes includes timely announcements that are not in the printed newsletter.

Signing up for email notification is a supplemental service that does not terminate delivery of printed newsletters. It is quick, free, and spamless. Why not sign up today?

PELS AdCom Meeting Highlights

The PELS Administrative Committee met in Miami Beach on 9 February in conjunction with the IEEE Applied Power Electronics Conference. The all-day meeting produced the following actions and approved motions:

Action Items

- Doug Hopkins will encourage the Power Sources Manufacturers Association to participate with PELS in possible standards development.
- Activity chairs with planned initiatives for 2004 will provide cost estimates to Treasurer Steve Leeb.
- The AdCom will review a fee schedule for providing specifying members with hardcopy versions of the *Transactions on Power Electronics* and will make a decision on 2004 fees for the next AdCom meeting in June.
- Bob Myers will prepare an advertisement and announcement material for the *Introduction to Power Electronics* CD-ROM developed by Dave Torrey.
- Myers will forward an educational pro-

gram initiated by Johann Kolar for posting on the PELS website.

- Jason Lai will work with the webmaster to create a link between the PELS home page and the Standards Association site.

Motions

- Approved a slate of chair appointments made by President Dean Patterson.
- Authorized an additional \$10,000 advance loan to PESC'03.
- Specified the allocation of \$10,000 from the 2004 budget to produce a video promoting power electronics.
- Raised Society annual dues to \$20, effective in 2004.
- Increased cash prizes for the Society's three major awards – William E. Newell (from \$1,700 to \$5,000), Distinguished Service (from \$1,200 to \$3,600) and Richard E. Bass Outstanding Young Power Electronics Engineer (from \$500 to \$1,500), the increases to be effective in 2004.

Bob Myers

PELS Executive Director

bob.myers@ieee.org

News from the Division Director

As the IEEE Division II Director, I represent PELS and three other societies on the IEEE Board of Directors, and am responsible for communicating between the societies and the Board. This year is likely to be one of action to make changes that will improve the value of IEEE membership. Much of the Board's February meeting was devoted to the discussion of long-term strategy and possible new developments. The Board is discussing a wide range of issues in products and services, and also issues of cost reduction and improved operations. With the rapid growth of electronic publishing, the nature of IEEE technical information is changing at an unprecedented pace. The IEEE hopes to be a proactive force for positive change in the preparation and delivery of information.

Another key issue continues to be that of IEEE finances. Every effort is needed to manage costs. An outside study, mentioned in the November column, has suggested a number of ways in which IEEE operations can be streamlined. Not surprisingly, electronic publishing is not necessarily less costly than more conventional publishing. Papers must still be reviewed and edited, prepared in useful form, and delivered to members and libraries. The IEEEExplore tool (<http://ieeexplore.ieee.org>) is powerful and

has been extremely successful, but of course there is an extensive operation behind it. An important new product is the "Member Digital Library" that provides limited downloads through IEEEExplore for a monthly fee. This product helps narrow the gap between individual members and large library subscribers. "Mid-range" products to better serve small businesses or small libraries are in final stages of development.

Beyond information, conferences and chapter activities are likely to be some of



our most valuable activities for a long time to come. I hope you are able to take advantage of local chapter or section meetings, and that you have been able to attend a PELS conference. Power electronics is still a key technology for the world's future. Interaction with those in the field is the best way to exchange good ideas, network, and improve the way we do things. Is IEEE doing what you expect to make you a better engineer? Your ideas and suggestions are welcome.

Philip Krein

p.krein@ieee.org

Call for Short Technical Articles

I would like to invite you to contribute a short technical article to the Power Electronics Society (PELS) *Newsletter*. In response to positive reader comments on the "Tricks of the Trade" column, we are planning to increase the number of *Newsletter* pages to accommodate more and longer articles of this type. However, we editors cannot implement the plan without creative engineers who step forward and contribute articles. If it is not obvious, this is where you come in. The success of this endeavor depends on having good sources of material.

The articles are intended for practicing power-electronics engineers, so they should be practical in nature. This is an excellent opportunity for members to contribute simpler circuits, formulae, or techniques they have developed which do not fall within the usual scope of conference or transactions papers. Examples of topics from recent "Tricks of the Trade" articles in this *Newsletter* include measurement of thermal loss

using an ice chest, delayed sweep triggering of digital scopes, use of Poincare maps for stability analysis, automatic resonant switches, a simple diode-based solar-cell model, and in this issue, optimal timing of synchronous-rectifier gate drive. Suggestions for future topics include state-of-the-art surveys (e.g., capacitors, micro-inductors, supercaps, controllers, converters, topologies), short tutorials, design "rules of thumb," debugging tips, etc.

The maximum length of a short technical article is two (2) pages, including a short biography and close-up photo of the author. The editors will generally format articles using two columns, as is typical for IEEE papers.

The preferred method of submittal is email. If you submit an item via email, be prepared upon request to follow up with hard copy via postal mail. Mail sent via postal and other carriers is acceptable also. Mailed items can be mailed on a PC-format 3.5-inch diskette, CD-ROM, or even hardcopy. Any items submitted on diskettes or CDs should be accompanied by black & white hardcopy of suitable quality to be electronically scanned if necessary.

If the article contains graphics (figures, photos, etc.), please include a separate file

for each graphic in its most suitable format. The preferred format for figures and charts is a vector-based graphic (e.g., encapsulated PostScript, or EPS). Any fonts used in a vector-based graphic must be embedded in the graphics file. Bit-mapped graphics (e.g., photos) must have adequate resolution to print at 300 dots per inch at the final print size. The preferred format for photos is unedited images from a digital camera. If a digital photo is not available, an ordinary print can be scanned electronically and submitted as an email attachment, or mailed directly to me for scanning. Scanned photos should be saved in TIF format at a resolution of at least 400 x 600 pixels. Please **do not embed** graphic images in the email message, nor inside any other attached file, such as Microsoft Word®.

An Editorial Board will help me review these articles. As with any IEEE publication, authors must sign an IEEE copyright agreement before technical material can be published.

Please let me know if I can answer any questions or assist in any way.

Juan Carlos Balda
Associate Editor, PELS Newsletter
Phone: +1 479 575 6578
FAX: +1 479 575 7967
jbalda@uark.edu



President's Message from page 5
experience not only for the students but also for the organization structure, which depended heavily on Phil Krein (who championed this project from its inception) and Jason Lai from our society, and Randy Gemmen from the National Energy Technology Laboratory (NETL).

That first competition so clearly demonstrated its value that the second, current one, 2002/2003, has achieved ongoing support from the USA Department of Energy and Department of Defense, without any reservation on international participation. Hence the name "International Future Energy Challenge." It has been expanded to have two topics, so Universities can choose to suit their expertise. One topic pursues the domestic fuel cell inverter, but with a more targeted and difficult specification, and the other pursues an economical, efficient 500W drive for the appliance industry. At a recent meeting at APEC we had presentations from Mike Adams, from Fuel Cell Technology in Ontario, Canada who are providing the 5 kW solid-oxide fuel cell system as the model for the inverter part of the challenge, and Roy Miller from Advanced Energy in North Carolina who are provid-

ing a complete industrial test facility for the 500-watt-drive part of the competition. These two players are providing a real industrial interface. Jo Howze is in charge overall and is supported with a strong committee, with particularly significant input from Phil Krein, Steve Pekarek, Marcelo Simoes, Sam Biondo, and Randy Gemmen.

This challenge has 19 universities entered, from 4 countries. I am confident that this activity will grow substantially, and topics for the next challenge, for 2004/2005 are currently being sought. If you have any ideas on what really needs to be done that will conserve energy and present a challenge to our finest young minds, let us know.

Dean Patterson
Ph: +1 803 777 7362
FAX: +1 803 777 8045
patterson@ieee.org

Microprocessor Power from pg 7
increase cost. Equally important, a designer can easily adapt as needs dictate without costly redesign.

As tomorrow's microprocessors enter the market, power management solutions that employ innovative control architectures like these will stand ready to meet the challenge head on.

[This work is excerpted from A. Lidow and G. Sheridan, "Defining the future for microprocessor power delivery," in *18th IEEE Applied Power Electronics Conference and Exposition Record, APEC '03*, vol. 1, pp. 3-9, 2003.]

Alex Lidow is currently CEO of International Rectifier, a leading supplier of power semiconductors and systems. He joined International Rectifier in 1977 as a Research & Development Engineer and subsequently served the company as Vice President of R&D. Mr. Lidow was promoted to Executive Vice President of Manufacturing & Technology in 1985 and served as President of IR's Electronic Products Division beginning in 1989. He advanced to Executive Vice President of Operations in 1992 and was named to his current position in March 1995.



A co-inventor of the HEXFET® power MOSFET, Lidow holds nine patents on power semiconductor technology and has numerous publications on related subjects.

He earned a B.S. degree in Applied Physics from California Institute of Technology in 1975. He received a Ph.D. in Applied Physics from Stanford University as a Hertz Foundation Fellow. His professional associations include the IEEE, the Electrochemical Society, and Tau Beta Pi.

Book Review[®] of Two Related Books on Electric Drives

1. Ned Mohan, *Electric Drives: An Integrative Approach*, 2003 ed. Minneapolis: www.MNPERE.com, 2003, 464 pp., ISBN-0-9715292-1-3.
2. Ned Mohan, *Advanced Electric Drives: Analysis, Control and Modeling using Simulink[®]* Minneapolis: www.MNPERE.com, 2001, 184 pp., ISBN 0-9715292-0-5.

Professor Ned Mohan of the University of Minnesota has written a two-volume series of textbooks on electric drives. The books represent viewpoints from many colleagues, especially due to the feedback from the participants in six National-Science-Foundation-sponsored educational workshops that Dr. Mohan has organized, starting in 1991, in the fields of Power Electronics and Electric Drives. These two excellent books, where the students need no prior knowledge of electric machines theory, are designed to teach from basics to advanced topics in electric machines and drives in only two semesters. In writing these books, the author has paid a great deal of attention to generate student interest, and at the same time to provide them with a solid foundation in the field of Electric Drives, without any prior knowledge of Electric Machine Theory.

The first book in this series, *Electric Drives: An Integrative Approach*, discusses modern adjustable-speed drives in the context of exciting applications such as energy conservation, wind energy, hybrid-electric vehicles, etc. The steady-state analysis of electric drives in this book uses electric machine models that are derived from simple physical principles with minimum amount of mathematics, hence are very easy to understand. These models (unlike in any other book) provide complete continuity to advanced topics discussed in the next book. This introductory book is now adopted as a textbook at a large number of universities around the world.

In the second book in this series, *Advanced Electric Drives: Analysis, Control and Modeling using Simulink[®]*, steady-state models of electric machines are extended to the study of advanced topics such as dynamic analysis, control and modeling of electric drives using Simulink. Simulink-based design examples included in this book (also on the CD-rom attached to the book) allow meaningful design-oriented problems to be assigned as homework. I imagine that students will find the confirmation of analytical discussion by simulation results extremely satisfying.

The approach of the author in these two textbooks is totally unique and represents a sharp departure from that in traditional text-

books now in use for several decades. In the traditional approach, for example, induction motors are first discussed for line-fed operation and only in later chapters their operation for speed control is discussed. In the approach used by the author, electric machines are introduced on the premise that they will be operated in a controlled manner through power electronics, albeit discussed in their steady state in the first of the two-volume series. This approach has two distinct advantages:

1. It allows electric machines to be introduced in the context of exciting applications of electric drives to generate student interest. A large increase in student enrollment is documented at schools that have tried this way of teaching.

2. Electric machines are analyzed in the first textbook in a manner that reveals the physical basis on which they operate, thus allowing a clear understanding of how they ought to be controlled for optimum performance as discussed in the second textbook. The author has succeeded in making the space-vector theory approachable to undergraduates in the first introductory course, in fact, making it easier than phasor calculations by providing physical meaning to space vectors. The author, to his credit, also satisfies those looking for tradition equivalent circuits of machines for line-fed operation.

In addition to the traditional Solutions Manual for instructors of the back-of-the-chapter problems, these two textbooks are accompanied by unusual teaching aids. Each of these textbooks contains a CD-rom with a large number of PowerPoint[®]-based slides that students can print and bring to classes to take notes on, and to quickly review the material before exams. That's not all – the Instructor's CD (only for instructors) contains audio clips, usually a minute or two long attached to each slide, that highlight the pitfalls to be avoided and the main points to be emphasized in class. Instructors using this approach will find these CDs extremely useful in preparing and organizing their lectures. The second textbook also contains the Simulink files of the design examples.

In summary, I strongly recommend all engineering educators in this field to evalu-

ate these two textbooks for themselves. I believe that they (and their students) will be pleasantly surprised.

Given the emphasis on applications, these books are equally valuable for self-learning to practicing engineers who wish to control machines for optimum performance in various applications.

Reviewed by Tore M. Undeland (<http://www.elkraft.ntnu.no/~undeland/>), who is a professor in Power Electronics at the Norwegian University of Science and Technology, NTNU, Trondheim, Norway, and an adjunct professor in Electrical Power Engineering at Chalmers University of Technology, Gothenburg, Sweden. An IEEE Fellow, he is also a scientific advisor to SINTEF Energy Research.



Editor's note: Believing there is value from personal referrals in selecting great books from among the good, we occasionally publish book reviews in the PELS Newsletter. You are invited to contribute a book review to the series. Please send the editor <pelsnews@ieee.org> a short prioritized list of outstanding technical books for which you could write a review to share with your colleagues.

PESC[®] 2008 Call for Proposals

The location of PESC 2008 will be decided at PESC 2003 in Acapulco, Mexico. In keeping with tradition, the 2008 conference would be held normally in Europe (Region 8).

A proposal outline for PESC 2008 should be submitted by May 16, 2003 to the PESC Steering Committee Chair via the PELS Executive Director, Bob Myers <bob.myers@ieee.org>. The proposal should include: local conference facilities, name of proposed General Chair, and outline of budget. Each PESC 2008 proposer should plan to make a short presentation to the PESC Steering Committee in Acapulco on Sunday, June 15, 2003.

Prof. W.G. Hurley
Chair, PESC Steering Committee
National University of Ireland
Galway, Ireland
ger.hurley@niugalway.ie

An Introduction to Power Electronics[®]

An Educational Tutorial in CD-ROM



by **David A. Torrey**
Advanced Energy Conversion, LLC
Ballston Spa, NY



- **An Introduction to Power Electronics** (video and PDF slides)
 - Introduction and Overview
 - Circuit Analysis
 - Practical Issues
 - Distinguishing Features of Power Electronics
 - Modeling and Control
 - A Look at Sample Hardware
- **Handouts in PDF**
 - Notes on Circuit Analysis
 - Modeling Power Electronic Converters in Matlab
 - Notes on Signal Analysis
 - An Overview of Inverters
- **Links to IEEE and IEEE Power Electronics Activities**
 - IEEE
 - IEEE Industry Applications Society
 - IEEE Industrial Electronics Society,
 - IEEE Power Electronics Society

For complete details on this comprehensive course – a presentation totaling seven hours and more than 500 slides – log on to <http://www.advanced-energy-conv.com/marketing.html>

An Introduction to Power Electronics

\$150 (USD)

To order, contact Bob Myers (IAS Administrator and PELS Executive Director)
at bob.myers@ieee.org or phone +1 (310) 446-8280



This tutorial is jointly sponsored by the Industry Applications Society and Power Electronics Society of IEEE

An Introduction to Power Electronics

Please send me this CD ROM Tutorial. Quantity ____ at \$150 (US) each

Name _____

Organization _____

Address _____ Dept or MS _____

City _____ State (Province) _____ Country _____

Phone _____ E-mail _____

Method of payment:

Check (USD) _____; Credit card Visa _____, MasterCard _____, American Express _____

Credit Card Number _____ Expiration Date _____

The charge on your credit card will read Myers/Smith, Inc.

Send to Myers/Smith, 799 North Beverly Glen, Los Angeles, CA 90077 USA

Or FAX to +1 310 446-8390

© IEEE, 2003, all rights reserved

This tutorial is jointly sponsored by the IEEE Industry Applications Society and the IEEE Power Electronics Society.

Invitation To INTELEC® '03 In Yokohama, Japan

On behalf of the INTELEC '03 Organizing Committee, it is my great pleasure to invite you to attend the 25th International Telecommunications Energy Conference.

INTELEC '03 will be held from Sunday through Thursday, October 19—23, 2003, at Pacifico Yokohama (Pacific Convention Plaza Yokohama), in Yokohama, Japan. The conference marks the 25th anniversary of INTELEC since its establishment, and is thus called "Silver Anniversary INTELEC." INTELEC is an international forum to discuss issues concerning energy supply to telecommunications systems, electronic apparatus, and IT systems. In addition to the technical sessions and tutorial sessions, new products will be on display. Of course, there will also be an excellent social program.

The theme chosen for this conference

Diagnostics Symposium Coming to Atlanta in August

The 4th IEEE International Symposium on Diagnostics for Electric Machines, Power Electronics and Drives (SDEMPED '03) is coming to Atlanta, August 24-26, 2003. The symposium brings together engineers interested in the latest advances in diagnostics and condition monitoring, not only for electric machines, also for power electronics and drives.

This is the first time this specialized symposium will be held in the US, and the first time it will be sponsored by PELS. The previous three SDEMPED's were all held in Europe. Bringing the Symposium to the US promises to increase participation by US industries and academics involved in this very important and rapidly expanding new area.

Many companies in motor control and protection, and power supplies are now considering the significant advantages of low-cost integrated diagnostics and condition monitoring in their products. A symposium like this allows engineers to present results and discuss the issues in an intimate and focused forum.

The Symposium will be held at the beautiful Evergreen Conference Resort, inside Stone Mountain Park, Georgia. For complete details and registration information please visit <http://www.myers-smith.org/sdemped/sdemped03.html>.

Tom Habetler
General Co-Chair

is "Powering the Broadband Network." Topics of energy supply to telecommunications networks, internet data centers, and mobile communication systems in the approaching broadband era will be presented and discussed.

Yokohama is a well-known port town and was one of the first cities to modernize in Japan. It is located close to the capital, Tokyo, and has a population of more than three million, second only to Tokyo. It features the newly developed Minato-Mirai 21 area where the Pacifico Yokohama is located, the beautiful Japanese-style garden Sankeien, one of the world's largest Chinatown districts, and the Motomachi and Isezaki-cho shopping areas with the latest



Minato-Mirai 21 area, where
INTELEC '03 will be held

fashions. There are also many famous sightseeing places in the vicinity, such as the ancient capital Kamakura, as well as the national parks of Hakone, Mt. Fuji and Nikko. It is also easy to visit Kyoto, Nara or Hiroshima by bullet train. October is without doubt the best season in Japan for sightseeing, travel, and of course, conferences.

Please access the INTELEC'03 web site for further details and information on how you can participate in this major event. The INTELEC home page <http://www.intelec.org/> has a link to the site. If you are interested in advertising your products, consider having a booth at the INTELEC'03 exhibition. This venue provides great exposure to an expert and influential audience, and only limited space remains. Information on the exhibition is available at <http://www.ics-inc.co.jp/intelec/exhibition/>.

We look forward to welcoming you to INTELEC '03. See you in Yokohama!

Katsuichi Yotsumoto
General Chairman, INTELEC '03



Show Off Your Membership In the Power Electronics Society



Order your PELS shirt today. The polo shirt is maroon with the PELS logo on the left breast and the IEEE logo on the right sleeve. The shirt is available in sizes ranging from small to XX large.

To order send full payment (checks only, please) and the coupon below to:

Bob Myers
PELS Executive Director
799 North Beverly Glen
Los Angeles, CA 90077 USA



Name _____

Mailing Address _____

City _____ State/Province _____

Country _____ Mail Code _____

Size & Quantity: XXL _____ XL _____ L _____ M _____ S _____

Total Number _____ Total Price (@\$27 USD each) _____

Only checks will be accepted (sorry, no cash or credit cards). Make checks payable to "IEEE PELS." Price per shirt includes shipping and handling.



APEC® '03 Micromouse Contest

The 17th annual APEC Micromouse Contest was held at the Fontainebleau Hotel in Miami, Florida on February 10, 2003. A total of 4 mice were on hand, including 2 foreign teams. For the second time in a row Min 3 from Singapore came in first with the best score and the fastest run. Min 2 also from Singapore by the same designer was awarded the second prize. WingWing from Korea received the third prize. The Best Student Prize also went to WingWing. All the contestants are listed in Table 1.

Table 1. Contestants in APEC '03 Micromouse Contest

<u>Mouse Name</u>	<u>Designer</u>	<u>Country</u>
Min 2	Beng Kiat Ng	Singapore
MITEE Mouse 7	David Otten	United States
WingWing	Kim Sanghoon	Korea
Min 3	Beng Kiat Ng	Singapore

Cash prizes were awarded again this year. Min 3 received US\$150 for first place, and WingWing received US\$150 for the best student entry.

The contest was held on Monday night after the exposition so that everyone at the conference could attend. To handle the audience of over 100 people, an aerial view of the maze was projected on a large screen behind the judge's table. The contest was run on a new maze imported from Korea.

Gerardo Molina prepared the maze design once again. APEC has developed a reputation for very difficult maze designs. This year's design had two long paths to the center, 97 and 101 squares long respectively. All mice used the shorter path. Long straights and plenty of diagonals were the order of the day.

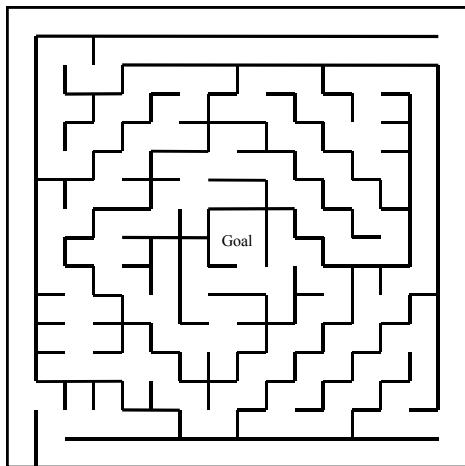

↑ Start APEC '03 Maze Design

Table 2 contains a list of the scores for each mouse that was able to solve the maze. The score is based on 1/30 of the time used to search the maze prior to the start of each run (*maze time*), and the time of that run (*run time*). If the mouse has not crashed or been restarted prior to the start of a run, a bonus of 3 seconds is subtracted from the score.

Min 2 and Min 3 were designed and built by Mr. Beng Kiat Ng, a lecturer at Ngee Ann Polytechnic in Singapore. His colleague, Mr. Toh Kok Hwa, helped with the

mechanical construction. Two of Mr. Ng's students were the handlers at the contest. Lim Youming operated Min 2 and Lai Weixiong operated Min 3. Both mice use 6-volt dc motors and 6-cell Ni-MHr batter-

and precise in flying, so he hopes his mouse will be also. This stepper-motor-driven wheel chair uses an AMD Am188es processor with 128KB of RAM and ROM. The power comes from 16 AAA size NiCd cells. Six infrared sensors measure distance by detecting the intensity of light reflected off the walls. Programming was mostly done in C with a little assembly language. WingWing came in first at the 20th Korean Microrobot contest held at Seoul National University last September. He also came in 3rd at the All Japan Final last November.

In November last year at the 23rd All Japan Final, a rule was changed to allow each entry only 5 minutes for its runs instead of the 7 minutes allowed the previous year. Realizing that with its historically slow searching, MITEE Mouse 7 may not even finish the search, let alone make any speed runs, designer David Otten spent much of his time improving this aspect of its operation. Unfortunately the night before the APEC contest he detected another bug in

Table 2. Scores for All Completed Runs of each Mouse

<u>Mouse Name</u>	<u>Run #</u>	<u>Run Time</u>	<u>Maze Time</u>	<u>Bonus</u>	<u>Score</u>
Min 3	1	66.07	0.00	-3	63.07
	2	11.92	4.25	-3	13.17
	3	11.64	5.49	-3	14.13
	4	11.26	6.71	-3	14.97
Min 2	1	69.38	0.00	-3	66.38
	2	13.23	5.13	-3	15.36
WingWing	1	43.17	0.00	-3	40.17
	3	12.47	4.07		16.54
	4	12.48	5.46		17.94
	6	12.03	7.8		19.83
MITEE Mouse 7	1	146.98	0.00	-3	143.98
	2	22.73	15.49	-3	35.22
	3	18.34	17.16	-3	32.50
	4	16.06	19.26		35.32

Overall: Best Score = 13.17 seconds, Fastest Run = 11.26 seconds

ies. Min 3 came in 2nd at the 23rd All Japan Final held last November. It was also awarded a special prize for reliability since it never crashed and always came back to the start square on its own between runs.

WingWing is the creation of Kim Sanghoon, normally an undergraduate at Korea University, but currently working for 3 years at an internet software company in lieu of his military service obligation. He chose this name for his mouse because it means wing in English and the sound of a flying bee in Korean. As a bee is very quick

the search code, so he used the older and slower search routines. This accounts in part for the large maze time associated with all the runs. Mr. Otten and his partner Tony Caloggero are staff members at the Massachusetts Institute of Technology.

For more information, including complete contest rules, see the APEC website at http://www.apec-conf.org/APEC_MicroMouse_Contest_Rules.html.

David Otten
APEC Micromouse Chair

APEC 2003 Recap

from page 9

APEC held its 17th annual MicroMouse competition. [See the article on the facing page for more information.]

Another APEC tradition is the Exhibit Hall drawings where we give prizes to attendees who answer our survey. The prizes awarded were a Panasonic DVD player, an Apple IPOD (MP3 player), an Olympus Zoom Camera, a Panasonic Camcorder, and a \$100 Home Depot gift certificate. The International Rectifier booth was voted by attendees as having the best appearance, the best give-away, and the happiest sales person.

The most popular RAP session was titled "Power Supply 'Digital Control'—Real or Virtual." Panel Moderator Arnold Alderman indicated that the outcome is "too early to know. It's inevitable—not a quantum jump." He said "there is a fear factor" about it.

Almost 50 spouses and guests participated in our excursions. On Monday they toured classic Miami including the famous Art Deco District. On Tuesday they took a waterway tour of Miami, South Beach, and cruised past the homes of the "stars."

The Wednesday evening dinner cruise was held on board the magnificent yacht "Lady Windridge" as it cruised the inter-coastal waterways to show the night lights of Miami's skyline.

Looking ahead, APEC 2004 will return to the Disneyland Hotel in Anaheim, CA. The conference runs February 22–26, 2004; see www.apec-conf.org for details.

Note: Anyone interested in being a speaker at APEC 2004 must submit an Abstract and Digest no later than July 28, 2003.

Larry Gilbert
APEC Publicity Chair
LGPWR@aol.com

RUGGED DC POWER SUPPLIES

PQ SERIES 3.3 TO 10 KW
SQ SERIES 20 TO 30 KW
MQ SERIES 20 TO 60 KW



FEATURES	BENEFITS
Many models	10 to 600 Vdc, 5 to 3600 Adc.
High-Power Factor	Reduces input current demand.
Current fed design	More robust than voltage fed designs. Disturbances cannot saturate isolation transformer.
Polyphase choppers	Fast responding, low ripple power processing.
Local OVP and OCP	Convenient front panel controls for displaying and setting over voltage and over current trip.
Mechanical contactor	Removes ac power from the power circuit for enhanced safety.
Inrush limiting	Step-start contactor arrangement precharges capacitors minimizing inrush currents.
Remote analog programming	Voltage, current, over voltage trip, and over current trip can be remotely programmed via resistance, voltage, current, or optional IEEE488/RS232.
Series and parallel master/slave	Allows series or parallel combinations of power supplies with one unit controlling the system.
Optical isolation	All front panel digital controls can be accessed from rear connectors. All digital lines have ohmic isolation eliminating ground loops.



MAGNA-POWER
ELECTRONICS, INC.

81 Fulton Street, Boonton, NJ 07005
(973) 263-0017 FAX: (973) 263-1928
E-mail: sales@magna-power.com
<http://www.magna-power.com>

Photos from APEC® 2003, Miami Beach, Florida



TOP (L-R) Plenary speakers' luncheon; a technical session; Micromouse contestants David Otten, Lim Youming, Lai Weixiong; **MIDDLE** Bob White, Pallab Midya, and Manny Landsman receive society awards from Awards Chair Chris Riddleberger; Tom Wilson Sr, Trey Burns, and Gene Wester socialize during the cruise; **BOTTOM** John Basset (center) presents exhibitor awards to unidentified IR representatives; Basset presents top door-prize to Zoya Kroner.



Meetings of Interest to PELS Members

CPE 2003, the 3rd International Workshop on Compatibility in Power Electronics, will be held May 28 – 30, 2003 in Gdańsk, Poland. For additional information visit <http://www.cpe2003.uz.zgora.pl>.

IEMDC 2003, the IEEE International Electric Machines and Drives Conference, is scheduled June 1 – 4, 2003 in Madison, Wisconsin USA. The IEEE Industrial Applications, Industrial Electronics, Power Electronics, and Power Engineering Societies are technical co-sponsors. For additional information visit <http://www.iemdc03.org>.

TELESCON 2003, the 4th International Telecommunications Energy Special Conference, sponsored by the IEEE Power Electronics Society, is scheduled June 8 – 13 in Rio De Janeiro, Brazil. See <http://www.cinintel.com.br/home.asp> or contact raul@cpqd.com.br for details.

PESC[®] 2003, the 34th Annual IEEE Power Electronics Specialists Conference, will be held June 15 – 19, 2003 in Acapulco, Mexico. PESC is sponsored by the IEEE Power Electronics Society. For additional information see within this *Newsletter* or visit <http://www/pesc03.org/>.

IPEMC 2003, the 4th International Power Electronics and Motion Con-

trol Conference, to be held in Xi'an, P.R. China, has been postponed one year from August 14 – 17, 2003 to the same dates in 2004, due to SARS. See <http://unit.xjtu.edu.cn/unit/ipemc2003/ipemc2003.html> or contact ipemc03@mail.xjtu.edu.cn for details. The IEEE Power Electronics Society is a technical co-sponsor.

SDEMPED 2003, the 4th IEEE International Symposium on Diagnostics for Electric Machines, Power Electronics and Drives, takes place August 24 – 26, 2003 in Atlanta, Georgia USA. SDEMPED is sponsored by the IEEE Power Electronics Society. Visit <http://www.dimie.uniovi.es/sdemped03.html> for additional information.

EPE 2003, the 10th European Conference on Power Electronics and Applications, takes place September 2 – 4 in Toulouse, France. Organized by the EPE Association, it is technically co-sponsored by the IEEE Power Electronics Society. Information can be found at <http://epe2003.inp-toulouse.fr> or contact epe-association@vub.ac.be.

MDMPEC 2003, a Workshop on Multimedia Delivery of Modern Power-Electronics Curriculum, takes place September 3 – 5 in Salerno, Italy. MDMPEC is co-sponsored by the IEEE

Power Electronics Society, the University of Salerno, and the University of Central Florida. For additional information see within this *Newsletter* or visit <http://www.mdmpec03.unisa.it>.

INTELEC[®] 2003, the 25th International Telecommunications Energy Conference, will be October 19 – 23 in Yokohama, Japan. The IEEE Power Electronics Society is the sole sponsor in even years, and is a technical co-sponsor in odd years. Visit <http://www.intelec.org> for more information.

PEDS 2003, the 5th IEEE International Conference on Power Electronics and Drive Systems, will be held November 17 – 20 in Singapore. The IEEE Power Electronics and Industry Applications Societies are technical co-sponsors. Visit <http://www.ieeepecs.org> for details.

APEC[®] 2004, the 19th Annual IEEE Applied Power Electronics Conference, sponsored by the IEEE Power Electronics Society, the IEEE Industry Applications Society, and the Power Sources Manufacturers Association, will be held February 22 – 26, 2004 at the Disneyland Hotel, Anaheim, California USA. Digests are due July 28, 2003. Visit <http://www.apec-conf.org> for current information.

The INSTITUTE OF ELECTRICAL & ELECTRONICS ENGINEERS, Inc.

445 Hoes Lane, P.O. Box 1331 • Piscataway, NJ 08855-1331, USA

Periodicals Postage
Paid at New York, NY
and at Additional
Mailing Offices

*Make your plans now
to attend*

PESC[®] 2003

**Hyatt Regency Acapulco
Acapulco, Mexico
June 15 – 19, 2003**