

The History of ISTECH

Shoji Tanaka

International Superconductivity Technology Center
Superconductivity Research Laboratory (retired)
10-13, Shinonome 1-chome, Koto-ku, Tokyo 135-0062, Japan
E-mail: tanaka@istec.or.jp

Abstract – In this article I address the origins and evolution of the International Superconductivity Technology Center (ISTECH) of Japan, in which I was involved since its day one until recently. My group at the University of Tokyo played the decisive role in the confirmation of the discovery of high-temperature superconductors (HTS) and this led to me accepting the leading role in the Japanese R&D effort towards the development and practical applications of HTS superconductors. At the Superconductivity Research Laboratory of ISTECH, remarkable results have been obtained in the previous projects such as the development of coated conductors and SFQ devices. These results have been inherited by new projects, which continue on our road towards the practical applications of superconductivity.

Received November 29, 2010; accepted February 11, 2011. Reference No. RN18; Category 13.

Keywords – Superconductivity, high-temperature superconductivity, cuprate, coated conductor, electric power grid, grid components, electronics, single flux quantum

I. HISTORY BEFORE HIGH-TEMPERATURE SUPERCONDUCTORS

1986 was a very special year in the research on superconductivity. The discovery of high- T_c (critical temperature) superconductivity in Ba-La-Cu-O oxides was first reported in September of 1986 [1]. Before this discovery, the probability of finding higher T_c superconductors was considered low, based on some interpretations of the BCS theory of superconductivity [2]. Indeed, there was no improvement on the T_c value for more than 10 years, since $T_c = 22\text{-}23$ K of was attained in A-15 Nb₃Ge. Of course, the search for higher T_c materials was not the only problem in physics of superconductivity. However, it was important not only for basic physics, but also because of possible future applications.

Under these conditions, Vitaly Ginzburg of USSR (at that time) discussed theoretically the possibility of high-temperature superconductivity with colleagues at the Lebedev Physics Institute in Moscow, and the results of these discussions were published in 1977 as a book entitled “High Temperature Superconductivity” [3]. When we read the book again, we notice that they argued for the possibility of high

temperature superconductivity based on the most current status of physics at that time, but have not mentioned the possibility of oxide superconductors.

In the US, Bernd Matthias, the renowned and most prolific discoverer of many superconductor families, who first synthesized most of A15 compounds, paid relatively little attention to the oxides. While he and his students discovered some new oxide superconductors, their experimental T_c values were much lower than in A15 compounds.

Arthur W. Sleight, then at Dupont, discovered in 1975 that the ternary oxide $\text{BaPb}_{1-x}\text{Bi}_x\text{O}_3$ (BPBO) showed superconductivity and its T_c depended upon the Bi substitution (index x) [4]. The maximum observed T_c was 13 K. It was remarkable at that time that an oxide material exhibited such a high transition temperature. Therefore, my group at the Department of Applied Physics, University of Tokyo, followed these experiments and confirmed that the carrier density of this material in the superconducting state was between one and two orders of magnitude lower than that of metallic superconductors. Thus we named this material a “low carrier density superconductor” [5].

Another ternary compounds, discovered in Switzerland in the early 1970s, with a T_c eventually approaching 16 K, were the Chevrel phases such as PbMo_6S_8 , which Matthias considered the first high-temperature ternary superconductors (1972). Such discoveries pointed towards the possibility of discovering higher T_c in ternary nonmetallic compounds.

Indeed, a research group “New Mechanism of Superconductivity” was organized in Japan around 1980, but mainly theorists discussed the possibility of high temperature superconductivity. In 1985, their arguments resulted in “Grants-in-Aid for Scientific Research” of the Ministry of Education, Science and Culture, also including experimentalists; their results were also connected to oxide superconductors.

Of course, independent of these material research activities, there existed in Japan big development projects on applications of low- T_c superconductivity. I'll mention here the MHD power generation (Electrotechnical Laboratory), the superconducting power generator (Ministry of International Trade and Industry; MITI), the Maglev Train (Ministry of Transportation) and the superconducting computer, (MITI). Superconducting wires used in the large-scale systems were all fabricated of NbTi alloys and operated at liquid helium (LHe) temperature. It was consequently difficult to avoid quenching. The quenching problem was especially severe in the development of the Maglev Train, which was led by the National Railway Company, with many companies such as Toshiba, Hitachi, Mitsubishi Electric, and Furukawa Electric joining the project. Niobium was the main material used in superconducting digital electronics, which was also operated in LHe. The Cryogenic Association of Japan was established in 1961, and the number of members was about 500.

II. ADVENT OF HIGH-TEMPERATURE SUPERCONDUCTOR

In spring of 1986, K. Alex Muller and J. Georg Bednorz of IBM in Switzerland replaced a part of La of LaCuO_3 with Ba, and they found the temperature dependence of resistance strongly depended on the strength of the current. They suggested the

possibility of percolative superconductivity in their samples with an onset temperature above 30 K and published their findings in a rather obscure journal, which appeared in September 1986 [1]. This result initially remained unnoticed by a good majority of researchers, but it attracted our and a few other researchers' attention.

In November of 1986, my group confirmed that barium-substituted La_2CuO_4 was an intrinsic high-temperature superconductor (HTS): we measured magnetic susceptibility and demonstrated fractional Meissner effect in our still imperfect samples. The week of that confirmation was one of the most exciting in my whole life (see the next page). We actually did not plan to present these results at the Material Research Society Meeting Symposium held in Boston at the end of November to early December 1986. However, another researcher reported observation of possible percolative superconductivity in an undefined La-Ba-Cu-O compound under high pressure. This important observation by Dr. C.W. (Paul) Chu immediately pointed the way also to the search for superconductors in similar compounds substituted not by La, but rather by smaller ionic radii elements such as the rare earths. Our Prof. Kitazawa thus announced conclusive Meissner effect results, with the fraction of superconducting phase in consecutively prepared samples increasing daily. We submitted our first magnetic susceptibility data to JJAP on November 22, 1986 [6]. Figure 1 shows the four members of my group, who co-authored that brief communication.



Fig. 1. Co-authors of the first communication in JJAP confirming that an La-Ba-Cu-O compound exhibits Meissner effect [6]. From left to right: Koichi Kitazawa, Shoji Tanaka, Shin-ichi Uchida and Hidenori Takagi.

Indeed, the ten days preceding our communication to the JJAP were among most exciting of my life. It was Wednesday, November 12, 1986: I returned to my home from the laboratory to change my clothes before attending the wedding ceremony of my graduate. I took a phone call from Shin-ichi Uchida. He talked to me in excitement, “This is a high- T_c superconductor! The T_c reaches 28K!” I asked him “What is the material?”, but he could not answer clearly. Actually it was difficult to define the material at that stage of the experiment.

Luckily, we were among the few who read the Bednorz and Muller paper [1]. We have been looking for a new material after BPBO, thus we tried to reproduce their compound in the BaLa–Cu–O system. Also luckily, we had a sensitive magnetic susceptometer and could measure the susceptibility of the material precisely. One of my graduate students, Haruhiko Ohara, measured this material with this susceptometer and found strong diamagnetic behavior indicative of the Meissner effect, which is the signature of superconductivity.

After seeing the data, I was convinced that this material contained a high- T_c superconductor phase. The diamagnetic susceptibility indicated that only a small fraction of the whole material could be superconducting. At the meeting of my laboratory on November 14, I said to all members “I’m convinced this material is a high T_c superconductor”. Although they were doubtful, they had already started to analyze the sample.

On Sunday morning, November 16, I was too excited to stay at my home and so I went to the laboratory. I met Hidenori Takagi just coming out from the measurement room. He reported to me “It is 2-1-4”. This was the moment of confirming the high- T_c superconductor. Bednorz and Muller replaced a part of La in LaCuO_3 by Ba, but a small amount of La_2CuO_4 was included in the material. The real superconductor was that where a part of La in La_2CuO_4 was replaced by Ba. Takagi and his colleagues synthesized 100% $(\text{La}_{1-x}\text{Ba}_x)_2\text{CuO}_4$ and they confirmed it showed the superconductivity. I was surprised by seeing the crystal structure of the material, because it was two-dimensional, a property I had pursued for a long time. It was a clear blue sky autumn day. I brought Takagi to a restaurant and thanked him for the achievement of his overnight work.

On Wednesday, November 19, a meeting was held by the Grant-In-Aid group of the Ministry of Education at a location on Izu peninsula, about 100 km away from Tokyo. I reported the data at the meeting, and almost all attendees supported our results. At that time, a volcano on Ohshima Island, close to Izu peninsula, erupted and inhabitants escaped from the island. After hearing my presentation, Hidetoshi Fukuyama shouted “Eruption, Eruption!”

News of our results announced in Boston instantaneously spread all over the world. Within days the race toward “High-temperature Superconductors” started. In February 1987, Paul Chu’s group at the University of Houston was first to synthesize a Y-Ba-Cu-O oxide material, which exhibited T_c higher than 90 K [7]. This gave a shock to the world.

Under these conditions, the usual American Physical Society March Meeting included a workshop on HTS held at the Hilton Hotel in New York on March 18th, 1987. More than 2000 scientists gathered at the meeting, which continued until the early morning hours. It was reported by New York Times to be the “Woodstock of Physics”,

and the meeting was later called the “Woodstock Meeting”. Note, at that time the Y-Ba-Cu-O compound having T_c above 90 K was still not fully identified. In April, the more-or-less correct identification was announced by Bell Laboratories [8].

After this “Woodstock”, the race to find new high- T_c superconducting materials continued all over the world. Copper oxides (cuprates) including bismuth were discovered by Hiroshi Maeda in Japan in 1988 (T_c up to 125 K). In the same year, thallium cuprate compounds (T_c approaching 130 K) were discovered in the US and announced at the new “Conference on Materials and Mechanisms of Superconductivity and High Temperature Superconductors (M2S-HTSC)”¹ held in Interlaken, Switzerland. In 1993 a mercury cuprate compound with T_c of 134 K was found, again in USA. After these materials, various kinds of other superconducting materials were discovered, but materials exhibiting T_c higher than the liquid nitrogen temperature (77 K) were limited to oxide cuprates.

III. A NEW R&D STRUCTURE

Science administrators in some countries felt that the HTS research and development needed a new research and development structure. In Japan, the Bureau of Industrial Technology belonging to MITI was planning big projects which would affect the industries of the future. The problem could have been to convince the industrial management, but many Japanese companies recognized the importance of HTS and were eager to join the new national projects. Especially, Tokyo Electric Power Company (TEPCO) was at the nucleus of these companies. TEPCO was the biggest electric power company in Japan, and it had an important position in the industries.

It was believed urgent to start national projects to follow the programmatic decisions and activities worldwide. Therefore, several companies, including TEPCO, sent researchers to my group at the University of Tokyo and also investigated the status of HTS in the world. The industrial researchers were educated as starters of a new research laboratory. The preparatory office for establishing a new laboratory was settled in a place close to MITI. Researchers in universities, young officers of MITI, and people from industries eagerly discussed the expectations and future national projects.

Eventually, preparations to establish ISTEC (the International Superconductivity Technology Center) were completed, and the founding meeting was held on January 14th 1988 with many concerned people invited. The “International” in the title meant that also foreign organizations could join the Center. The establishment of ISTEC was formally approved on January 21st and the first meeting of the board of directors was held on March 16th. Drs. Gaishi Hiraiwa of TEPCO was appointed President and I became the Vice President.

Supporting membership in ISTEC was to be “ordinary” and “special”. The special supporting member company paid membership fee twice as high as the ordinary

¹ This new international conference, created in response to emerging HTS materials, was a new reincarnation of the US “Conference on Superconductivity in d- and f- Band Metals” or “Rochester Conference”.

member, but had the prerogative to send researchers to the new laboratory which would be soon constructed and could also preferentially use patents resulting from expected new inventions.

Overall 105 companies joined ISTECH as supporting members, and among them 45 companies offered to become special supporting member. Of foreign companies, I like to mention IBM, which became an ordinary member. From this broad membership one obtains the impression that Japanese and other industries at that time nurtured high expectations for the high temperature superconductivity and its prompt industrial implementation.

MITI's Bureau of Industrial Technology organized a new national project "Superconducting Electron Materials/Devices". It was originally planned to be of 5-year duration, but later it was extended to 10 years. ISTECH was required to urgently form the required R&D structure and to start its activity.

IV. INTERNATIONAL EXCHANGE AND COOPERATION

In 1988, the year of the Woodstock Meeting, many researchers rushed into this field, and they competed to find new materials. It was said that more than 30 physical models were proposed even in the field of the basic theory of HTS. We judged in Japan that the isolation was deleterious under such confusing conditions and Japan should open her windows to the world. Consequently, we created the following new events and structures to realize international interchanges and have been inviting many foreign researchers. These events and structures included:

- a. The International Superconductivity Symposium (ISS) held annually; it has been attracting over 600 participants from about 20 countries and is now well-established internationally.
- b. The International Superconductivity Industry Summit (ISIS), co-sponsored by CCAS (the Coalition for the Commercial Application of Superconductors, USA) and CONECTUS (the CONsortium of European Companies determined To Use Superconductivity). It was also to be held every year.
- c. International Superconductivity Workshop held mainly in Japan, sometimes in Hawaii.
- d. The ISTECH Fellowship. We started to accept foreign researchers as research Fellows.

V. ESTABLISHING THE SUPERCONDUCTIVITY RESEARCH LABORATORY

There had been a mutual agreement between MITI and our industries that a subsidiary research laboratory of ISTECH will be established to perform the research on superconductivity. Special supporting member companies sent researchers to the laboratory and they were involved in the new national project. Originally, we planned to establish one laboratory named "Superconductivity Research Laboratory" (SRL) in Koto-ku in Tokyo, at a place which was owned by Tokyo Gas Company.

However, industries in Nagoya strongly wished to establish it in Nagoya. Therefore, we first established the “SRL Nagoya Branch” in the Fine Ceramic Center, which had been just organized by chance. Opening ceremony of the Nagoya Branch was held in July 8th 1988, prior to the opening of SRL itself. Dr. Izumi Hirabayashi, who was working in The University of Tokyo, The Institute for Solid State Physics, was assigned to be a manager of the Branch, and the basic research on future superconducting wire materials started here.

The SRL in Tokyo was established as planned in Toyosu of Koto-ku, and the opening ceremony was held in October 25th 1988 (Figure 2). For convenience, the SRL headquarters office settled in the middle of Tokyo, in the Shinbashi district. I became the Director General of SRL, and full-fledged research started immediately. Figure 3 shows a photo of the SRL building in 1988, while the SRL organization at that time is shown in Figure 4.



Fig. 2. The ISTEK inauguration ceremony, held on October 25, 1988. The person in front is the officiating Shinto priest. I’m standing fourth from the left in the first row.



Fig.3. The new SRL building in1988.

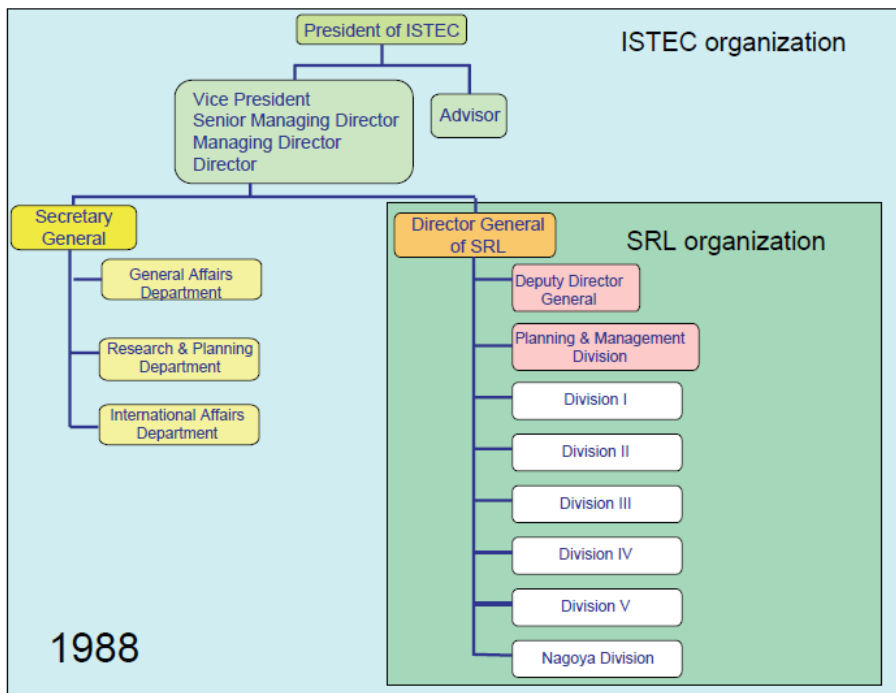

Fig.4. The ISTEC/SRL organization in 1988.

VI. ORGANIZATION OF SRL

The SRL started in 1988, but we didn't have specialists in HTS, which was a new face on the block with its physical properties not well known. Indeed, the HTS cuprates are a strange group of perovskite structure ceramic materials. Under these conditions, it was very difficult to organize a new laboratory with the personnel on the order of 100 researchers.

We thought it adequate to assign nearly 10 researchers to each research group, but it was difficult to find a suitable person for the leader or manager of the group. It was natural that there were no specialists in HTS and the future direction of the research on HTS could not be anticipated.

Under these circumstances, we assigned Dr. Naoki Koshizuka (Electro-Technical Laboratory, at that time) for a deputy Director General of SRL and the manager of the First Division (see Figure 4). His work was to establish an “evaluation technology” for the specific heat and magnetic susceptibility, which were the essential physical properties of HTS to be evaluated. The Second Division covered the most difficult work, “the search for a new material”. Dr. Hisao Yamauchi, who has been active in USA, was then sent back to be assigned the management of the Second Division. The Third Division aimed at precisely grasping the basic properties of optical and electromagnetic characteristics of HTS and I was holding also the post of this Division manager. The Fourth Division aimed at developing an optimum synthesizing process for HTS; Dr. Yuh Shiohara, who was doing research on iron processing at MIT, was asked to return and become manager of this Division. The Fifth Division’s mission was to develop “thin film technology” which would be important for the future applications, and Dr. Tadataka Morishita, who was then working in the Science & Technology Research Laboratories of NHK, was assigned as manager of this Division. Dr. Yoichi Enomoto, who was working in NTT, was assigned in 1992 to become the manager of the Sixth Division, which covered the future “superconducting devices”.

Adding the manager of the Planning Division, who was temporally transferred from MITI, all together seven Divisions and the Nagoya Branch were organized.

After reorganizing a few times, the Tamachi Branch was opened in 1993 and the Morioka Branch in 1994. Consequently, the second-phase organization was completed as shown in Figure 5. Outside of the SRL itself, the organization of ISTECH (Figure 4) remained unchanged.

Research funds were obtained from the supporting member companies and also from the national projects of the Bureau of Industrial Technology of MITI through NEDO (New Energy and Industrial Technology Development Organization). Two researchers were temporally transferred from each special supporting member company.

The national project “Superconducting Electron Materials/Devices” was executed for ten years and ended in the fiscal year 1997. National projects in the following period are introduced below. During these first ten years, a number of technical papers published by SRL was about 1100 and 317 patents were filed.

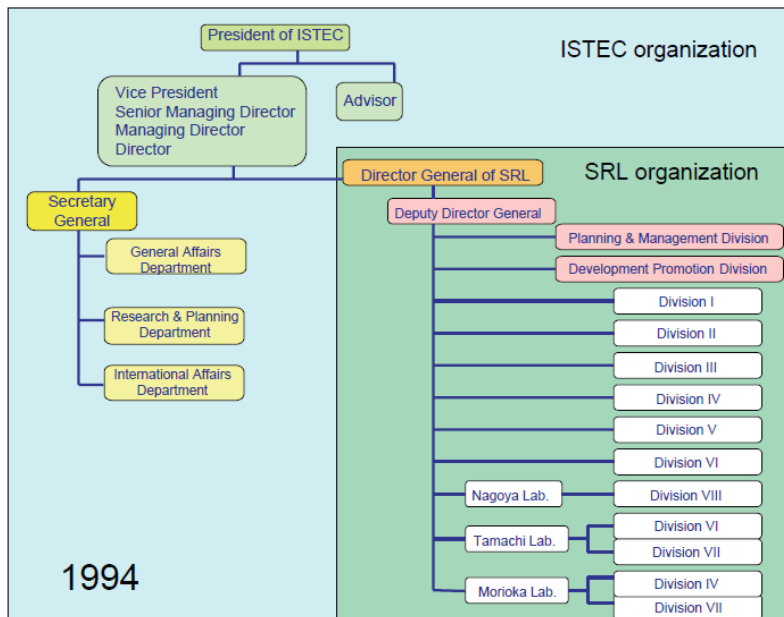

Fig.5. The ISTEC/SRL organization in 1994.

Until 1997, the highlights of achievements at SRL were:

- Fabrication of stable superconductor $Y_{1-x}Ca_xBa_2Cu_4O_8$ with T_c of 90K [9].
- Bulk material with high trapped magnetic field made by MPMG (Melt Powder Melt Grown) method [10,11].
- Growth of high quality one-inch class $NdBa_2Cu_3O_{7-x}$ single crystals [12,13].

Great significance for practical applications had the demonstrated magnetic levitation of large and heavy objects with the help of the MPMG technology (Figure 6).

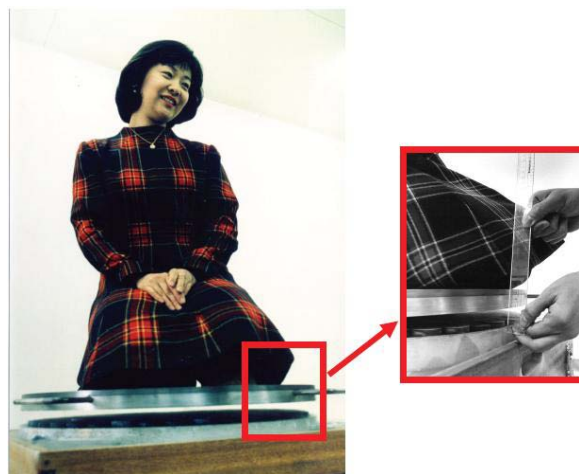

Fig. 6. Magnetic levitation using superconducting bulk materials made by MPMG.

VII. R&D ON FUNDAMENTAL SUPERCONDUCTING APPLICATION TECHNOLOGIES

The structure and physical properties of HTS cuprates were largely determined during the ten years from 1987 to 1997. The CuO_2 planes in the perovskite crystal have the most important role, and the superconductivity appears when doping carriers from outside. The compound's superconductivity is largely two-dimensional, and shows d-wave symmetry in the ab-plane. Therefore, the amount of current (current density) strongly depends on the angle between the direction of the current and that of main axis in the ab-plane. It was anticipated to be difficult to control the structure and microstructure of HTS crystals. We felt, we should solve many difficult problems before the realization of HTS applications becomes possible in the future. Considering these difficulties, MITI planned the next national project, the "R&D of Fundamental Superconducting Application Technologies" for ten years, and entrusted this project to ISTEC.

After 10 years since the HTS discovery, our industries were eager to apply the HTS in practical systems and obtain some benefits from their investment. They wanted cool the HTS systems with liquid nitrogen not any lower temperature coolant. Thallium mercury compounds were not desirable to use in practice, because of their poisonous nature. We thus selected the 123 cuprates such as $\text{RE}_1\text{Ba}_2\text{Cu}_3\text{O}_{7-\delta}$ (REBCO) where RE stand for yttrium (Y) or another rare- earth element.

From the view point of future applications, the most important technology was to develop the superconducting wire. Consequently, we reorganized our research structure accordingly and re-assigned the managerial responsibilities. Dr. Setsuko Tajima, who was working at the University of Tokyo, was assigned to be a manager of the Second Division, responsible for the basic physical properties of HTS materials. The Third Division (Tamachi Branch) was doing research on bulk superconductors, and Dr. Masato Murakami was assigned to be its manager. He had been developing high-quality bulk superconductors using the OCMG (Oxygen Controlled Melt Growth) method. The Fifth Division (Nagoya Branch) was now managed by Dr. Yutaka Yamada, who came from Toshiba Corporation, and this Division collaborated with the Fourth Division managed by Dr. Shiohara.

The most difficult topics included the development of superconducting electronic devices, which was the task of the Sixth and the Seventh Division. The Josephson junction devices fabricated of YBCO were unstable and long term research appeared necessary. Dr. Keiich Tanabe from NTT was assigned to be the manager of the Sixth Division to develop high-quality Josephson junctions. We established the Chiba Branch in Tokyo Denki University in 1988, and Dr. Enomoto became its manager.

Mainly in the US, digital SFQ (Single Flux Quantum) circuits were under development, and the possibility of SFQ-based Petaflops computers was under discussion. Thus we judged it important and valuable to develop low- T_c SFQ circuits although they required LHe cooling; we established the Tsukuba Branch in 2002 and the research on high-speed low temperature device started under the management of Dr. Mutsuo Hidaka from NEC.

To support the work of the Director General of SRL, Drs. Osamu Horigami and Shinya Hasuo joined SRL as Directors, respectively in 1998 and 2002.

VIII. ACHIEVEMENTS OF THE PROJECTS

Here, I like to mention the achievements of the two recently completed national projects: “R&D of Fundamental Superconducting Application Technologies” (I) and “Low-power Superconducting Network Device” (II). Activities of these projects are described in some detail in the ESNF article [RN12](#). I can thus list only their main achievements, without any discussion.

The project (I) started in 1998 and ended in 2008 with many fruitful results for coated conductors (CC). Basic technologies of CCs suitable for practical applications were developed in this project. The highlights are:

Development of high-performance coated conductors:

1. Large scale IBAD (Ion Beam Assisted Deposition) system with fabrication speed of 5 m/h,
2. Development of large-scale PLD (Pulsed Laser Deposition) method,
3. New intermediate buffer layer: introduction of CeO₂,
4. Demonstration of high performance long coated conductor: 500 m length, critical current $I_c = 350$ A.

An example of these results is given in Figure 7, which shows the I_c distribution in a 500-m-length tape of PLD-GdBCO on IBAD-GZO (Gallium Zirconate).

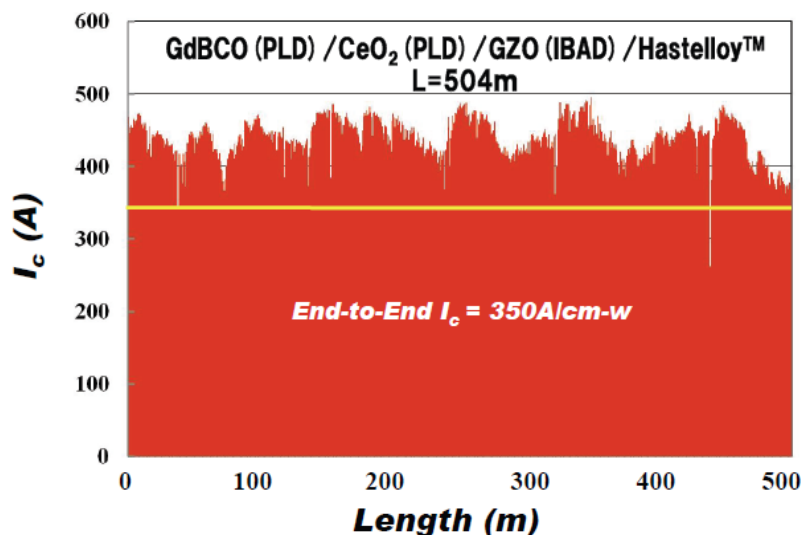

Fig.7. The I_c distribution in a 500-m-length tape of PLD-GdBCO on IBAD-GZO.

Figure 8 shows a PLD system in which a schematic illustration of multi-turn and multi-plume (MTMP) PLD is also shown. By using this system, high yields of material and a production rate as high as 5-10 m/h for the superconducting layer has been achieved.



Fig.8. The PLD fabrication system.

Improvement of low-cost coated conductors

1. Process development for fabricating thick (up to 2.5 μm) films by TFA-MOD method,
2. Attainment of high in-field performance (flux pinning) by BZO introduction,
3. Demonstration of high-performance long TFA-MOD-coated conductor of 500 m length, with $I_c = 310 \text{ A}$.²

Typical results obtained using the TFA-MOD process are shown in Figure 9. It compares the magnetic field angle (θ) dependence of the current density (J_c) of YBCO, with that of Zr-doped YSmBCO, and Zr-doped YGdBCO at the liquid nitrogen temperature and in the magnetic field of 1 T.

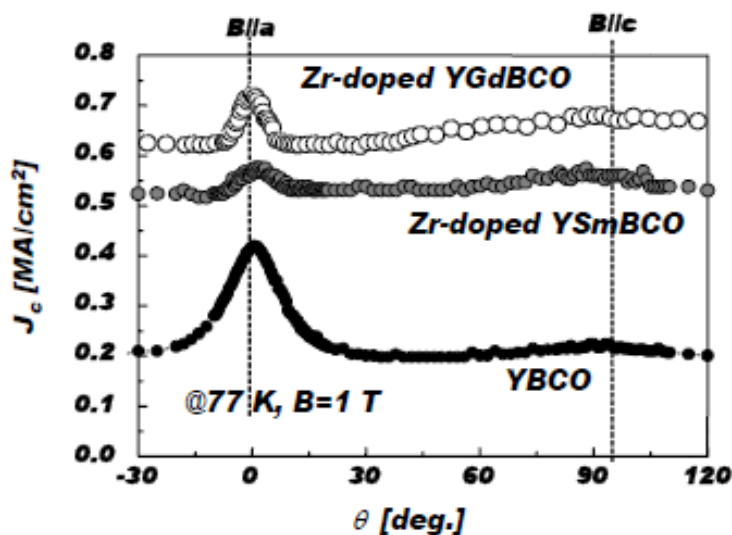

Fig.9. Magnetic field angle (θ) dependence of the current density (J_c) for three different films made by TFA-MOD.

² TFA-MOD is the acronym of Tri-Fluoro-Acetate-Metal-Organic-Deposition.

The project (II) “Low-power Superconducting Network Device” started in 2003 and ended in March of 2007. In this project HTS and LTS electronic devices were developed. The SRL highlights are:

Improvement of HTS devices

1. Development of integrated circuit fabrication process with HTS Josephson junctions,
2. Fabrication process with a standard deviation $1-\sigma$ of the critical current I_c of Josephson junctions of typically 6-10% and run to run spread of I_c of $\pm 12\%$.
3. Development of a sampler circuit shown in Figure 10; the sampler bandwidth exceeds 100 GHz.

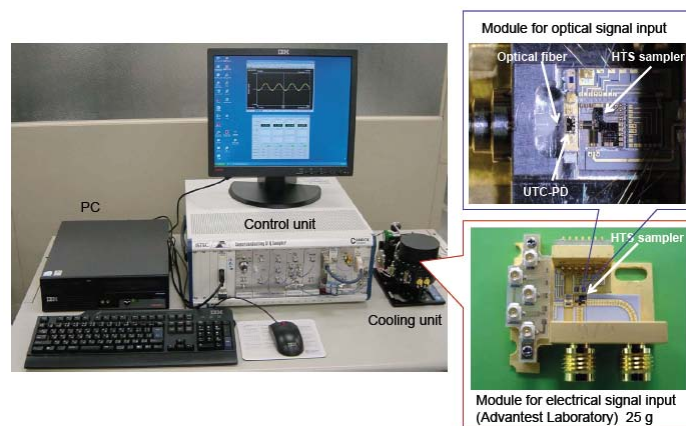

Fig.10. Sampling oscilloscope system with HTS integrated circuit.

Improvement of LTS devices

1. Integrated fabrication process with more than 10,000 Nb/AIO_x/Nb Josephson junctions and Nb wiring,
2. Integrated high-speed circuit design with 40GHz clock frequency,
3. High-speed packaging operating in a cryocooler,
4. High-speed small SFQ systems, such as the 4 x4 switch shown in Figure 11.

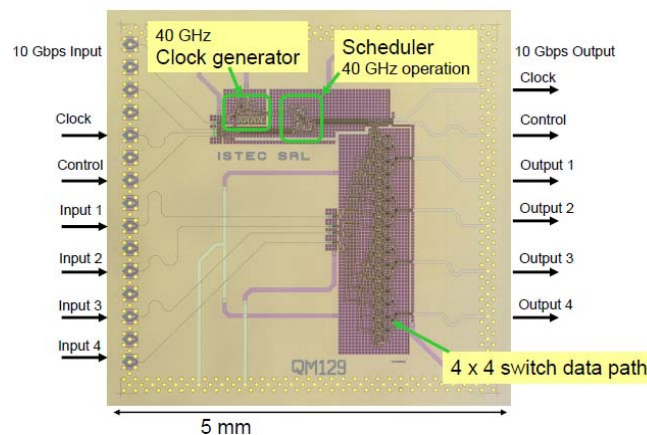

Fig.11. The 4 x4 switch chip.

The total number of technical paper, which SRL published from 1988 to 2009, is 3140, and the number of filed patent is 661.

IX. TOWARDS THE NEW ELECTRIC POWER GRID TECHNOLOGY

Recently, rapidly developing large population countries called BRICs³ emerged as major players in the world's market. Their consumption of energy and resources increases rapidly, which also results in the accelerated deterioration of the environment due to massive emission of CO₂ and of other pollutants. It is broadly believed that this is leading to a rapid change of climate with possibly catastrophic consequences. One of the contemplated countermeasures, now addressed mainly in the United States, is to restructure the old electric power generation and transmission network into so-called Smart Grid. In this restructuring the role of superconductivity technology can be quite large. With that background in mind, and under the usual MITI sponsorship, ISTECS started in spring of 2008 a new project, the "Technological Development of Yttrium-based Superconducting Power Equipment", or so-called M-PACC Project (Materials & Power Application of Coated Conductors Project). In order to facilitate this project, ISTECS organization was restructured in 2008 as shown in Figure 12. The project's plans and progress to date are discussed in the next section.

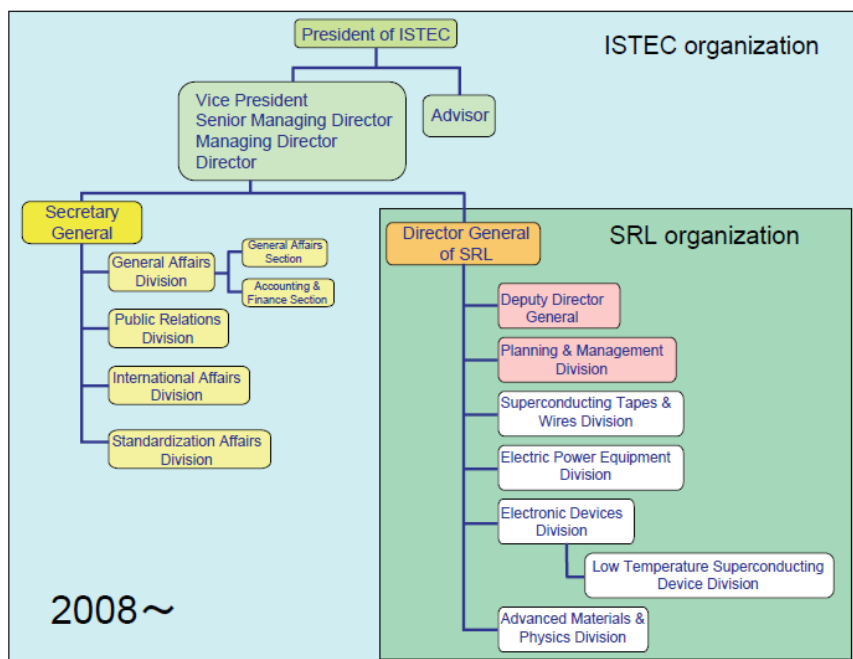

Fig.12. ISTECS organization since 2008.

³ BRIC is a grouping acronym that refers to the countries of Brazil, Russia, India, and China that are believed to all be at a similar stage of newly advanced economic development. BRICs cover 25% of the globe's territory and their population is 40% of the world's total.

X. THE NEW PROJECT: TECHNOLOGICAL DEVELOPMENT OF YTTRIUM-BASED SUPERCONDUCTING POWER EQUIPMENT

This project is to develop in five years, from 2008 to 2012, new prototype power systems close to practical application and incorporating the results of basic technology development in the past 20 years. The development targets are:

- (a) Basic technology of SMES⁴ with an energy of 2GJ for the stabilization of power systems,
- (b) Superconducting power cables for high-voltage (275 KV) and high current (66 KV) transmission systems, and also
- (c) Superconducting transformers.

Artist's concept illustrations of 2 GJ class SMES, of power cables, and a transformer are shown in Figures 13-15. It is, of course, necessary to develop low-cost systems in this project.

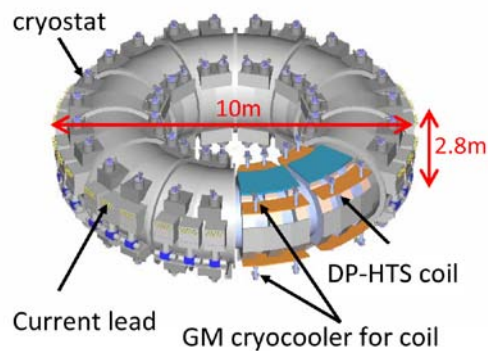

Fig.13. External view of the designed 2 GJ class SMES.

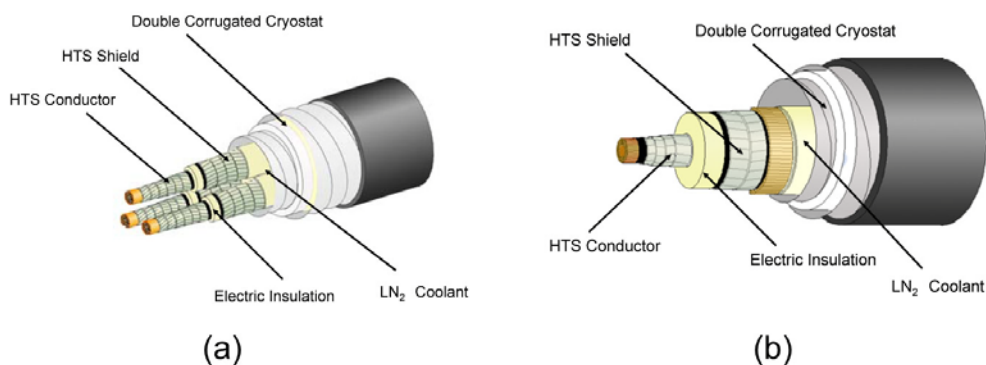

Fig.14. Superconducting power cables, (a) three-phase cable and (b) single-phase cable.

⁴ SMES in the acronym of superconducting magnetic energy storage.

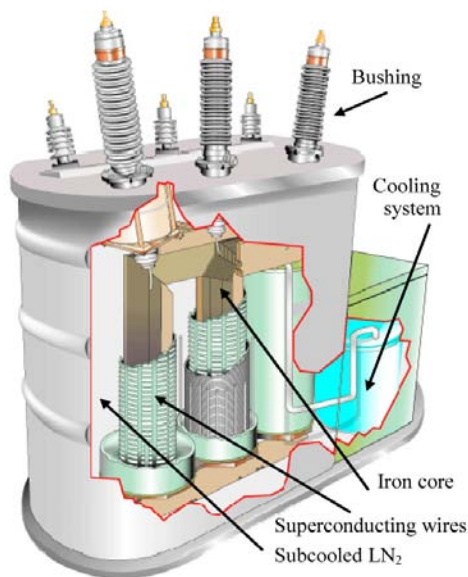

Fig.15. External view of the superconducting power transformer.

Of course, SRL cannot develop such system prototypes alone and close collaboration with industries is indispensable. The structure of collaboration with companies and government agencies is shown in Figure 16. I believe that the flexible structure of SRL has been facilitating a good collaboration of government, industry, and academia.

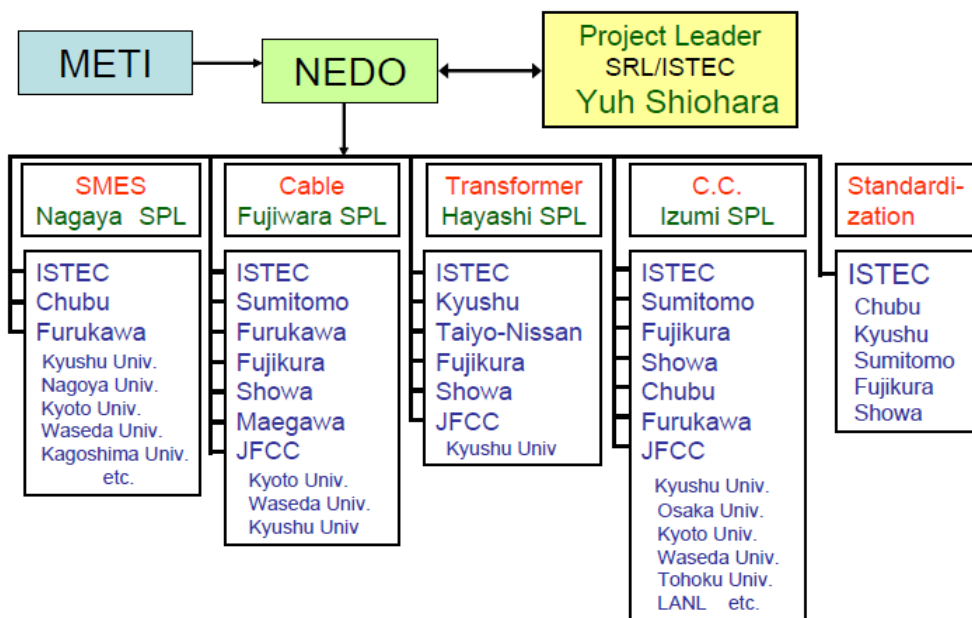

Fig.16. Collaboration structure of government, industry, and academia in the project of “Technological Development of Yttrium-based Superconducting Power Equipment”. The company names are in larger font, principal project leaders in green font.

XI. ELECTRONIC DEVICE PROGRAMS

The HTS electronic device technology developed in the “Low-power Superconducting Network Device” project was transferred to the SQUID (Superconducting Quantum Interface Device) technology for use in the manufacturing inspection of coated conductors. The integrated circuit technology with HTS Josephson junctions was also used to fabricate SQUIDs. Multiple SQUID sensors with pickup coils could be integrated on the same chip. For reduction of AC losses in coated conductors, it is essential to striate them into multiple filaments. This SQUID array chip has been developed for use in NDE (Non-Destructive Evaluation) of striated coated conductors.

The LTS digital electronic device technology is now being developed in a new NEDO project “Development of Next-generation High-efficiency Network Device Technology”, which started in June 2007 based on the results attained in the former project. The present project will continue until March 2012. It aims at establishing enabling technologies for the next generation high-efficiency communication networks. In this project, the main target is to develop highly efficient large-scale edge routers, ultra high-speed local area networks and related telecommunication systems. Main technologies are developed by using CMOS high-speed devices and optical I/O devices, but LTS devices are also included in this project. For example, a real-time monitoring system for optical communication will be developed using LTS SFQ devices.

XII. CONCLUDING REMARKS

Hundred years elapsed since the discovery of superconductivity in 1911, with 25 years since the discovery of HTS materials. True, the excitement and competitive research subsided 25 years after the HTS discovery, but it is a fact that thus far only oxide materials including copper (cuprates) have critical temperatures higher than the liquid nitrogen temperature (77K). The search for higher critical temperature and easier to fabricate superconductors continues, but it is a difficult endeavor with chances of success impossible to predict.

In Japan, we expect that practical power system components operational at liquid nitrogen temperature will appear at around 2015, nearly 30 years after the discovery of 1986.

When we compare the superconductivity technology with other resulting from a new discovery or invention, we notice that the 30 years period between the discovery and practical implementation is not that long. The first steam locomotive named Rocket appeared in 1814, nearly 50 years later after the invention of steam engine by James Watt in 1765. The world’s first railway constructed between Manchester and Liverpool in 1830 needed another 15 years to become a reality.

We expect that around 2030 the first magnetic levitated train will run as a regular traffic service in Japan. It will be then 45 years after the discovery of HTS.

As another example, let me mention that first manufactured integrated circuits appeared in the semiconductor industry in 1970, when more than 20 years had passed since the invention of transistor. This in turn caused the information technology revolution and resulted in the growth of big semiconductor industries from 1980 to

1990.

It is natural that 30 to 50 years are necessary after the basic discovery or invention of new technology to attain its commercialization and also acceptance in the society. I believe, it is important to do long term R&D into superconductivity in order to have it eventually accepted by the society.

More than 20 years elapsed since the establishment of ISTEC. Although this period seems to be long, it also seems to be short, as these 20 years have been very exciting for researchers and engineers involved in superconductivity, and for me personally too. After 20 years long years I finally retired from my ISTEC job and was sent off with a moving retirement party (Figure 17).



Fig. 17. Participants in my retirement party. I'm sitting in the middle of the first row, holding flowers.

At ISTEC/SRL we published many excellent results, but the real competition towards practical implementation is only beginning now. Power application seems to be practical in near future, and some electronic applications are also promising. Our efforts should be even more enthusiastic than before. The most important technologies of the future to contribute to the society need the sophistication of the superconductivity technology, with the high performance of superconductivity products leading to the expected advancement in reliability, and eventually also to lower cost.

I am convinced that the superconductor technology will emerge in various industrial fields and applications, such as the Smart Grid, and may contribute to some reduction in the terrestrial climate change. Therefore, superconductivity is a very fortunate technology.

ACKNOWLEDGEMENTS

I would like to express my sincere thanks to all people who worked with me during my stay at ISTECH. I thank also the following colleagues for their support in my writing of this article: Dr. Naoki Koshizuka, Dr. Tadataka Morishita, Dr. Osamu Horigami, and Dr. Shinya Hasuo. Dr. Hasuo also contributed guidelines for this article.

REFERENCES

-
- [1] J.G. Bednorz and K.A. Müller, "Possible high T_c superconductivity in the Ba-La-Cu-O system", *Z. Phys. B* **64**, 189 (1986); this June issue of the journal actually appeared in September 1986.
- [2] J. Bardeen, L. N. Cooper, and J. R. Schrieffer, "Microscopic Theory of Superconductivity", [Phys. Rev. **106**, 162-164 \(1957\)](#).
- [3] V.L. Ginzburg, D.A. Kirzhnits (Eds) *Problema Vysokotemperaturnoi Sverkhprovodimosti (The Problem of High-Temperature Superconductivity)* (Moscow: Nauka, 1977) [Translated into English: *High-Temperature Superconductivity*, New York Consultants Bureau, 1982].
- [4] A.W. Sleight, J.L. Gillson and P.E. Bierstedt. "High-temperature superconductivity in the BaPb_{1-x}Bi_xO₃ system", *Solid State Commun.* **17**, 27-28 (1975).
- [5] T.D. Thanh, A. Koma, S. Tanaka, "Superconductivity in the BaPb_{1-x}Bi_xO₃ system, *Appl. Phys. A* **22**, 205-212 (1980).
- [6] S.-I. Uchida, H. Takagi, K. Kitazawa, S. Tanaka, "High T_c superconductivity of La-Ba-Cu oxides", *Jpn. J. Appl. Phys.* **26**, L1-L2 (1987).
- [7] M. K. Wu, *et al.*, "Superconductivity at 93 K in a new mixed-phase Y-Ba-Cu-O compound system at ambient pressure", *Physical Review Letters* **58**, 908 (1987).
- [8] R.J. Cava, *et al.*, "Bulk superconductivity at 91 K in single-phase oxygen-deficient perovskite Ba₂YCu₃O_{9-δ}", *Phys.Rev.Lett.* **58**, 1676 (1987).
- [9] T.Miyatake, M.Kosuge, N.Koshizuka *et al.*, "Pressure Dependence of Superconducting Transition Temperature in Ca-doped YBa₂Cu₄O₈", *Physica C* **167**, 297 (1990).
- [10] L.T.Sagdahl, T.Laegreid, K.Fossheim *et al.*, "Restricted Reversible Region and Strongly Enhanced Pinning in MPMG YBa₂Cu₃O₇ with Y₂BaCuO₅ Inclusions", *Physica C* **172**, 495 (1990).
- [11] M. Murakami, T. Oyama, H. Fujimoto *et al.*, "Large Levitation Force Due to Flux Pinning in YBaCuO Superconductors Fabricated by Melt-Power-Melt-Growth Process", *Jpn. J. Appl. Phys. (Pt. 2)* **29**, L1991 (1990).
- [12] M. Nakamura, H. Kutami, Y. Shiohara, "Fabrication of NdBa₂Cu₃O_{7-δ} single crystals by the top-seeded solution-growth method in 1%, 21%, and 100% oxygen partial pressure atmosphere", *Physica C* **260**, 297-304 (1996).
- [13]. M. Kambara, X. Yao, M. Nakamura, Y. Shiohara and T. Umeda, "Fabrication of NdBCO single crystal oxide superconductor with enhanced superconductive properties", *J. Matl. Research* **12**, 2866 (1997).

About the Author:

Shoji Tanaka was born on September 19, 1927, in Odawara City, Kanagawa, Japan. He attended the prestigious University of Tokyo, obtained his B.S. in Applied Mathematics in 1950 and his Ph.D. in 1961, both at the Faculty of Engineering, University of Tokyo. In 1999 he was awarded a honorary D.Sc. by the Purdue University, USA, - for his achievements in superconductivity.

At the University of Tokyo, he was appointed Lecturer in 1955, Associate Professor in 1958 and Professor in 1968. In 1959-1961 he was a Research Associate at Purdue. In 1988 he became Prof.

Emeritus of his University and also of the Dept. of Physics, Tokai University. He was then appointed Director General of SRL and Vice-President of ISTEK in 1988, and served 20 years in these positions. He is currently an Advisor at ISTEK/SRL. In addition to superconductivity he had achievements in semiconductor device structures, electron transport phenomena and charge-density waves in two-dimensional materials.

For his achievements, Prof. Tanaka was decorated by the Emperor of Japan with the Purple Ribbon Medal in 1990 and with the 3rd Class Order of Merit of the Rising Sun in 1999. He also received numerous prizes: the Technical Achievement Prize of the World Congress on Superconductors in 1988, and the Greatest Prize of the Japan Ceramics Association, also in 1988. In 2003, the Japan Society of Applied Physics presented to Prof. Tanaka the Outstanding Achievement Award, and in 2004 the IEEE Council on Superconductivity presented to him the IEEE Max Swerdlow Award for Sustained Service to the Applied Superconductivity Community.



Prof. Tanaka with a doll representing him – a surprise presented by collaborators at the retirement party.