

Evaluation of Optimal Transfer Capability in Power system interconnection

Hyun-Il Son, Jin-O Kim, and In-Su Bae

Abstract— As the electrical power industry is restructured, the electrical power exchange is becoming extended. One of the key information used to determine how much power can be transferred through the network is known as available transfer capability (ATC). To calculate ATC, traditional deterministic approach is based on the severest case, but the approach has the complexity of procedure. Therefore, novel approach for ATC calculation is proposed using cost-optimization method in this paper, and is compared with well-being method and risk-benefit method. This paper proposes the optimal transfer capability of HVDC system between mainland and a separated island in Korea through these three methods. These methods will consider production cost, wheeling charge through HVDC system and outage cost with one depth (N-1 contingency).

Index Terms — ATC, Power system interconnection, well-being method, cost-optimization method, risk-benefit analysis, outage cost

I. INTRODUCTION

IN deregulated power market, system operators require efficient methods to calculate optimal transfer capability between two or more areas. Available transfer capability (ATC) of the transmission system is introduced by the United States Federal Energy Regulatory commission (FERC). The ATC is the reserved capability of transmission lines at a given time and varies from hour to hour based on the many factors. For example, the ATC is affected by generation dispatch, demand level, transfer capability between two areas, network topology and the limits on the transmission line. In the transmission system, optimal operation is dependent upon the ATC.

In Korea, mainland and a separated island are interconnected by HVDC. KEPCO (Korean Electric Power Corporation) has restructured the power industry and attempted to increase economic efficiency of the interconnection within reliability criteria. This paper proposes a cost-optimization method to obtain optimal ATC and the method is compared with well-being method and risk-benefit method. The well-being method is one of the reliability assessment techniques and the risk-benefit method is one of the economic assessment techniques to obtain optimal ATC.

The three methods use Local Marginal Price (LMP) of transfer capability between interconnected systems, production cost in generators and outage cost considering N-1 contingency. Data used in case study is LMP, generation data and demand of separated island in June 2008.

II. ATC AND THREE METHODS

A. Determination of Available Transfer Capability

By the NERC definition [1], ATC is determined by several parameters, namely, Total Transfer Capability (TTC), Transmission Reliability Margin (TRM), Existing Transmission Commitment (ETC), and Capacity Benefit Margin (CBM).

TTC and ATC can be expressed as Eqs. (1) and (2).

$$TTC = \text{Min}\{\text{Thermal, Voltage, Stability Limits}\} \quad (1)$$

$$ATC = TTC - TRM - ETC - CBM \quad (2)$$

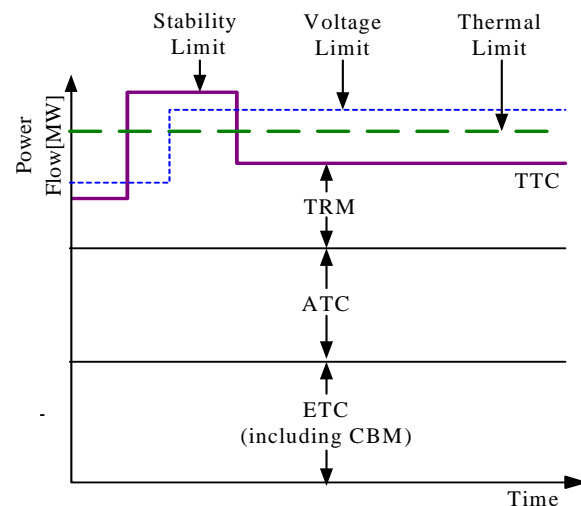

Fig 1. Available Transfer Capability

B. Determination of cost-optimization method

Cost-optimization method is one of ATC calculation method, and is used to calculate optimal transfer capability in this paper. The computation of total cost through cost calculation can be expressed as Eq. (3). [2]

$$\min [C] = C_G + C_W + C_O \quad (3)$$

H. I. Son is graduate student with the Department of Electrical Engineering at Hanyang University, Seoul, KOREA (e-mail: hison@hanyang.ac.kr).

J. O. Kim is a Professor with the Department of Electrical Engineering at Hanyang University, Seoul, KOREA (e-mail: jokim@hanyang.ac.kr).

I. S. Bae is a Professor with the Department of Electrical Engineering at Kangwon University, Gangwon-do, KOREA (e-mail: isbae@kangwon.ac.kr).

where, C : Total cost[$\$/\text{MW}$],

C_G : Production cost of generators [$\$/\text{MW}$]

C_W : Wheeling charge[$\$/\text{MW}$]

C_O : Outage cost[$\$/\text{MW}$]

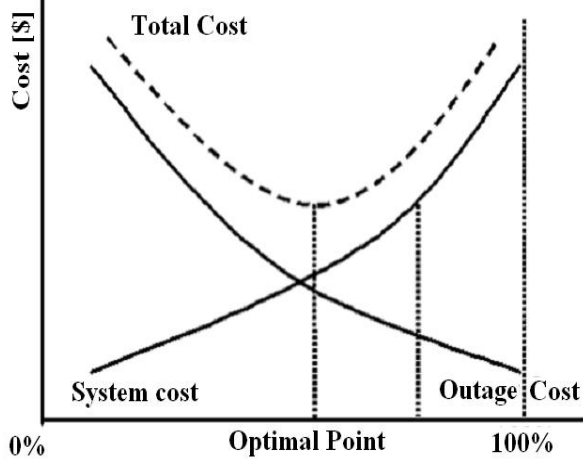

Fig 2. Determination of optimal cost point

All the above defined parameters and variables are relevant to local generators, outage cost and wheeling charge passing through interconnection line. The object function in eq. (3) should be minimized to obtain the optimal transfer capability.

- Calculation of outage cost

Outage cost can be obtained by two courses. Firstly, it is damage of customer who is not supplied electric power by contingency. Secondly, it is restoration expenditure and amount of reduction money due to contingency. [3]

In this paper, the interruption cost by economic activity is formulated as Eq. (4).

$$C_e = \frac{\text{Value added by economic acticity}}{\text{Power input by economic activity}} \quad (4)$$

Calculation of outage cost can be represented as Eq. (5).

$$C_o(t) = ENS(t) \times C_e \quad (5)$$

where, ENS(t) : expected not supplied energy at time t [MWh]

C_e : consumed electric energy by GNP [$\$/\text{MWh}$]

- Calculation of wheeling charge

Wheeling charge through interconnection line is decided by LMP and transfer capability.

$$C_w(t) = LMP(t) \times T(t) \quad (6)$$

where, LMP(t) : local marginal price at time t [$\$/\text{MW}$]

T(t) : transfer capability in interconnection line [MW]

- Calculation of production cost

Production cost consists of fixed and changeable costs. Usually, fixed cost is relatively less than changeable one. It is

assumed fuel cost equals production cost, because the changeable fuel cost takes the most part of expense composition,

Eq. (7) means production cost.

$$C_G(t) = \sum_{i=1}^{k(t)-1} (G_i \times g_i) + \left(D(t) - \left(T(t) + \sum_{i=1}^{k(t)-1} G_i \right) \right) \times g_{k(t)} \quad (7)$$

where, k(t) : number of generating generators at time t

G_i : maximum capability of i th generator [MW]

g_i : i th generator's production cost per MW [$\$/\text{MW}$]

D(t) : demand level [MW]

C. Determination of well-being method

The concepts of the basic probabilistic method designated as the EPRI method [4] are illustrated in detail in Reference 5. The main advantage of the well-being method is that it combines deterministic considerations and probabilistic indices of systems as well. [6]

- Approach well-being method

Process of reliability assessment in the well-being method is begun from the evaluation of 'At risk' state. When outage happens, system state is transferred to 'Marginal' state or 'At risk' state. The first step considers every outage and outage probability, and calculates 'At risk' probability. The second step calculates 'Healthy' probability in keeping their operating condition. Finally, 'Marginal' probability can be calculated, since the summation of every probability is 1.

$$P_m = 1 - (P_h + P_r) \quad (8)$$

where, P_m : 'Marginal' state probability,

P_h : 'Healthy' state probability

P_r : 'At risk' state probability.

$$P_r = 1 - \bigcup_{i=1}^n P_i \quad (9)$$

$$P_h = \bigcup_{i=1}^n P_i^2 \quad (10)$$

$$P_m = \bigcup_{i=1}^n P_i - \bigcup_{i=1}^n P_i^2 \quad (11)$$

where, n : number of components in system

D. Determination of risk-benefit method

- Benefit function

Benefit function is the sum of four-kind functions. First, profit from transmission system may be exposed by transmission owner's profits-increase. Second, transfer capability enlargement can delay a required transmission system expansion due to the increased load demand. Benefit function also includes those delayed expansions. Third benefit can be calculated by the profit of utilities. Forth, benefit function includes power loss due to transfer capability [7].

Now, Benefit function is:

$$B(T) = \alpha_w \cdot B_w(T) + \alpha_e \cdot B_e(T) + \alpha_u \cdot B_u(T) - \alpha_l \cdot C_l(T) \quad (12)$$

$$\begin{aligned} B_w(T) &= LMP_{av} \times T \\ B_e(T) &= C_d \cdot e^{\frac{r \cdot Y_d}{D_g} - 1} \\ B_u(T) &= C_s \cdot (D_{av} - T) \\ C_l &= K_l \cdot \beta_l \cdot T \end{aligned} \quad (13)$$

where, $\alpha_w, \alpha_e, \alpha_u, \alpha_l$: weighting factor

B_w : Benefits in power market

T : transfer capability [MW] : $0 \leq T \leq 300$ [MW]

LMP_{av} : Average LMP [₩/MWh]

B_e : Benefits of delayed a transmission expansion

C_d : Capital delayed a transmission system expansion

r : Annual rate of interest

Y_d : Year of delayed a transmission expansion

D_g : Rate of demand growth

B_u : Benefit of utility

C_s : Customer price [₩/MWh]

D_{av} : Average Demand [MW]

C_l : Power loss of transfer capability [MW]

K_l : cost value of power loss [₩/MWh]

β_l : Rate of power and power loss

- Risk function

Due to the complicated power system, risk function is represented in probabilistic function form. Risk function includes outage cost, generating cost for outage capability and power loss cost.

Risk function is expressed as

$$R(T) = O(T, T_p) \cdot FOR_{interconnection} \quad (14)$$

$$O(T, T_p) = \alpha_c \cdot C_e \cdot (T - T_p) \cdot t_s + \alpha_t \cdot g_t \cdot (T - T_p) + \alpha_l \cdot C_l(T_p) \quad (15)$$

where, $\alpha_c, \alpha_t, \alpha_l$: weighting factor

T_p : Transfer capability after outage

$FOR_{interconnection}$: Forced outage rate of interconnection lines

- Determination of optimal transfer capability

For determination of optimal transfer capability, net benefit - difference between benefit function and risk function - should be maximized. Optimal transfer capability is determined at the point where the differential point of net benefit equals zero.

$$\begin{aligned} NB(T) &= B(T) - R(T) \\ \frac{dNB(T)}{dT} &= \frac{dB(T)}{dT} - \frac{dR(T)}{dT} = 0 \quad (16) \\ \frac{dB(T)}{dT} &= \frac{dR(T)}{dT} \end{aligned}$$

Eq. (16) is approximated to Eq. (17).

$$B(T_{n-1} + \Delta T) - B(T_{n-1}) = R(T_{n-1} + \Delta T) - R(T_{n-1}) \quad (17)$$

E. Comparison of evaluation methods

Cost-optimization method will be compared with well-being method and risk-benefit method.

Table 1. Major considerations by evaluation methods

Method	Consideration
Cost-optimization	generating cost, wheeling cost, outage cost
Well-being	state probability, outage of components
Risk-benefit	market benefit, utility benefit, capital benefit of delayed expansion, power loss, Outage, FOR

III. CASE STUDY

A. Overview of Jeju in Korea

Jeju is biggest island in Korea, and is supplied 40% of present demand from mainland. If production cost of generators is higher than market price in mainland, island should receive more power. On the contrary, if LMP is more expensive than production cost and island has enough generation capability, island can supply electric power to mainland.

In June 2008, demand increases about 10 [%] per year, and production cost is about 3~4 times of LMP. Demand was low in daybreak and peak load happened at 22 hours. Average demand was 295~410[MW].

There are 4 power plants and 9 generators in separated island. Production cost and capability of all generators are shown in Fig 3.

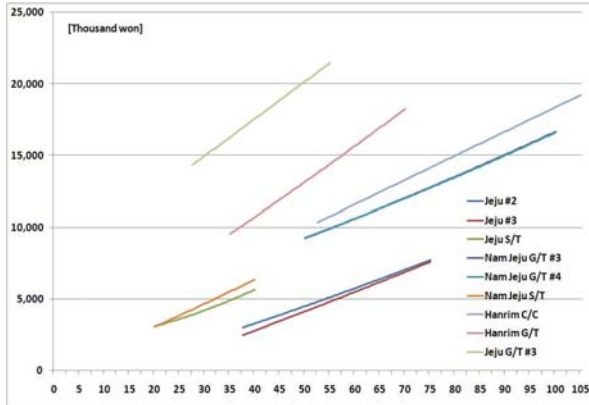

Fig 3. Generating Capability and Cost in generators

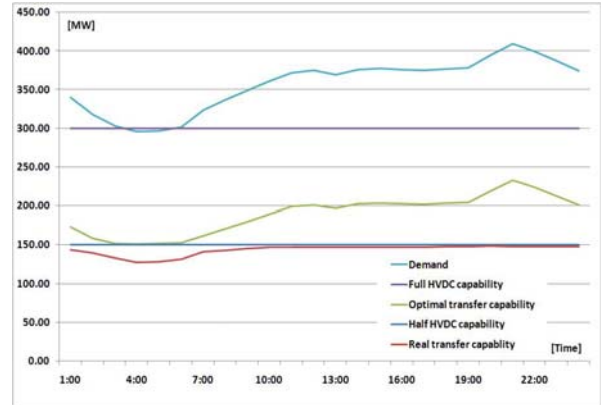

Fig 4. Computation of optimal capability using cost-optimization

B. Determination of cost-optimization method

Now, it is assumed that HVDC system is used by 0[%], 50[%] and 100[%] of maximum capability.

- Case 1. 0[%] usage of HVDC system

Without transfer capability through HVDC system, 9 generators supply total demand of island. Jeju #2, #3, ST and Nam Jeju #3 always supply power. Nam Jeju #4 and Nam Jeju ST operate timely according to demand. Hanrim GT, CC and Jeju GT #3, however, are the reserve capability.

Calculation of production cost considers generator operating hours, minimal generating capability, starting cost, starting time and production cost per MW.

Outage cost supposes contingency of Nam Jeju #3 which has biggest generating capability, and considers starting time of other generator.

- Case 2. 50[%] usage of HVDC system

Transfer capability through HVDC system is 150 [MW] that is 50% of maximum rating. Jeju #2, #3, ST and HVDC always supply power, and other generators are the reserve capability.

Two events are assumed to measure outage cost.

- *Event A*: Contingency occurs in one line of HVDC system,
- *Event B*: Contingency occurs in Jeju #3 and Jeju ST.

- Case 3. 100[%] usage of HVDC system

In this case, HVDC system is fully used as much as maximum rating. As demand exceeds 300 [MW] Jeju #2 and #3, which have the lowest production cost per MW, should supply power.

Two events are assumed to measure outage cost.

- *Event A* – Contingency occurs in one line of HVDC system,
- *Event B* – Contingency occurs in both lines of HVDC system.

- Computation of optimal transfer capability

Fig. 4 shows the optimal transfer capability about case 1, 2 and 3 using least square curve fitting. Optimal transfer capability of HVDC system is 150~225[MW] or 50~58[%] of demand.

C. Determination of well-being method

In well-being method, when demand is flat, sum of state probability is 1. According to the variation of system condition, well-being method can calculate each state probability.

Table 2. Outage rate of island's power supply

Supplier	Capacity	FOR	
HVDC system	300 MW	3.8 %	150 MW * 2
Hanrim C/C	105 MW	7 %	
Jeju #2, #3	150 MW	5 %	75MW * 2
Jeju GT #3	55 MW	6 %	
Nam Jeju GT	200 MW	5 %	100MW * 2

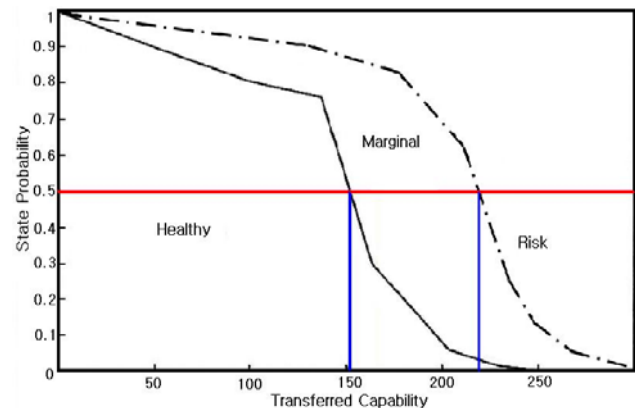

Fig 5. Computation of optimal capability using well-being method

Optimal transfer capability of HVDC system is 155~215[MW] in the well-being method.

D. Determination of Risk-Benefit method

Benefit function is expressed as Eq. (18).

$$\begin{aligned}
 B(T) &= \alpha_w B_w(T) + \alpha_e B_e(T) + \alpha_u B_u(T) \\
 &= LMP \cdot T + C_d \left\{ e^{\frac{T}{D_s}} \right\} + 1948T + 1680 \quad (18)
 \end{aligned}$$

Fig. 6 shows that transfer capability using risk-benefit

method of HVDC system, and the optimal value is 180[MW].

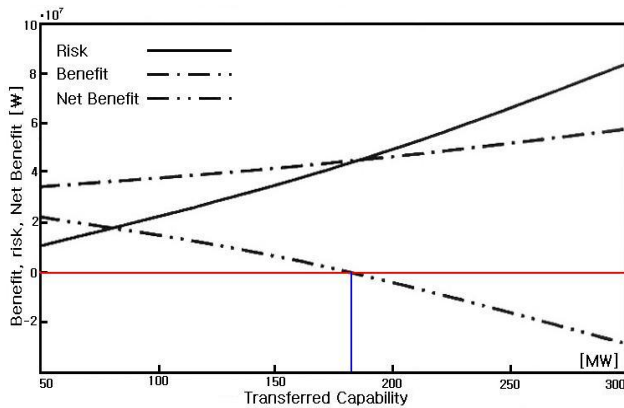

Fig 6. Computation of optimal capability using well-being method

E. Comparison of three methods

Cost-optimization method is compared with well-being method and risk-benefit method which considers reliability and economic aspect, respectively.

Table 3. Conclusion of three methods

Method	Optimal transfer capability
Cost-optimization method	150 ~ 225 [MW]
Well-being method	155 ~ 215 [MW]
Risk-benefit method	180 [MW]

The cost-optimization method considers reliability and economic assessments, while the well-being method considers only reliability assessment. The result of proposed method exists within the result of the well-being method. Also, the cost-optimization method optimizes hourly transfer capability, while the risk-benefit method shows only one optimal value.

IV. CONCLUSION

In response to the conflicting interests of various market participants and the demand of power system operators for enhancement of power system operation, this paper proposed equations designed to apply cost-optimization method to calculation and evaluation of optimal transfer capability. The method uses LMP of transfer capability between interconnected systems, production cost in generators and outage cost considering N-1 contingency. In the case study, the method is compared with well-being method and risk-benefit method to show merits. The result of cost-optimization method exists within optimal transfer capability using reliability assessment, and shows hourly optimal transfer capability compared with optimal value of economic method.

V. REFERENCES

- [1] North American Electric Reliability Council (NERC), "Available Transfer Capability -Definitions and Determinations", NERC Report, June 1996.
- [2] H.I.Son, D.J.Shin, J.O.Kim, "Evaluation of Optimal Transfer Capability in Haenam-Jeju HVDC system Based on Cost optimization.", KIEE

International Transactions on Power Engineering. Vol. 5-A. No.3 pp.9-15. Sep. 2005

- [3] S.B.Choi, D.K.Kim, S.H.Jeon, H.S.Ryu, "Evaluation of the Customer Interruption Cost taking into consideration Macro Economic Approach in LPREA", Power System Technology, 2002. Proceedings. PowerCon 2002. International Conference on, Vol.4, pp.2358-2362, 2002.
- [4] Final Report, "Composite-System Reliability Evaluation: Phase 1 – Scoping Study", Tech. report EPRI EL-5290, Project 2581-1, December 1987.
- [5] Billinton, R. and Allan, R. N., Reliability Evaluation of Power System, Longman, 1984
- [6] R. Billinton, S. Aboreshaid, M. Fotuhi-Firuzbad, "Well-being Analysis For HVDC Transmission System", IEEE Transactions on Power System, Vol. 12, No. 2, May. 1997.
- [7] K.Audomvongseree, and A.Yokoyama, "Consideration of an Appropriate TTC by Probabilistic Approach." IEEE Transactions on Power Systems, Vol. 19, No.1. Feb. 2004.