

# *IEEE R10 NEWSLETTER*



# IEEE REGION 10 TODAY

JANUARY  
2021  
EDITION

***[This page intentionally left blank]***

# CONTENTS

<b>WELCOMING MESSAGES</b> .....	<b>5</b>
MESSAGE FROM 2019-2020 IEEE REGION 10 DIRECTOR .....	5
MESSAGE FROM 2021-2022 IEEE REGION 10 DIRECTOR .....	6
MESSAGE FROM IEEE REGION 10 NEWSLETTER COORDINATOR.....	7
<b>1. SPECIAL REPORTS ON R10 FLAGSHIP EVENTS</b> .....	<b>9</b>
IEEE REGION 10 CONFERENCE 2020 (TENCON2020) .....	9
IEEE R10 HUMANITARIAN TECHNOLOGY CONFERENCE 2020 (R10HTC 2020) .....	12
IEEE R10 SYWL VIRTUAL CONGRESS 2020 (SYWL2020).....	17
<b>2. TECHNICAL COLUMN</b> .....	<b>26</b>
NEUROMORPHIC SYSTEM AND INTEGRATED CIRCUITS .....	26
FROM IMAGE/VIDEO COMPRESSION TO MULTI-MODAL DATA ORGANIZATION FOR THE FUTURE IOT ERA .....	29
<b>3. R10 PERSONALITIES OF THE MONTH</b> .....	<b>33</b>
R10 PERSONALITY OF THE MONTH – ATUL NEGI .....	33
R10 WIE PERSONALITY OF THE MONTH – QIAOWEI YUAN .....	34
R10 YP PERSONALITY OF THE MONTH – ARAVINDHAN ANBAZHAGAN .....	35
R10 STUDENT PERSONALITY OF THE MONTH – INDHUMATHI GUNASEKARAN.....	36
R10 LIFE MEMBER PERSONALITY OF THE MONTH – A. G. HAREENDRALAL .....	37
R10 COVID19 PERSONALITIES OF THE MONTH – C SUBRAMANIAM, SYUHaida ISMAIL AND WAN NURUL MARDIAH WAN MOHD RANI .....	38
<b>4. R10 ORGANIZATIONAL UNITS OF THE MONTH</b> .....	<b>41</b>
R10 LARGE SECTION OF THE MONTH – HONG KONG SECTION .....	41
R10 MEDIUM SECTION OF THE MONTH – TAINAN SECTION.....	42
R10 SMALL SECTION OF THE MONTH – AUSTRALIAN CAPITAL TERRITORY (ACT) SECTION .....	43
R10 STUDENT BRANCH OF THE MONTH – UCET ISLAMIA UNIVERSITY OF BAHAWALPUR.....	44
R10 STUDENT BRANCH OF THE MONTH – BANGLADESH UNIVERSITY OF ENGINEERING & TECHNOLOGY.....	46
<b>5. R10 UPDATES</b> .....	<b>49</b>
R10 SECTION INCENTIVES 2020.....	49
R10 EDUCATIONAL ACTIVITIES COMMITTEE UPDATE .....	51
R10 WEBINAR: A DIALOGUE WITH IEEE MANAGEMENT COUNCIL SPEAKERS.....	52
<b>6. SECTION AND SUBSECTION ACTIVITIES</b> .....	<b>55</b>
IEEE BANGLADESH SECTION .....	55
IEEE GUJARAT SECTION .....	57
IEEE HIROSHIMA SECTION.....	58
IEEE KARACHI SECTION.....	58
IEEE MADRAS SECTION .....	60
IEEE MALAYSIA SECTION .....	61
IEEE SRI LANKA SECTION .....	62
IEEE TOKYO SECTION .....	63
IEEE WESTERN AUSTRALIA SECTION.....	63
<b>7. AFFINITY GROUP AND CHAPTER ACTIVITIES</b> .....	<b>66</b>
IEEE WOMEN IN ENGINEERING AG BANGLADESH .....	66
IEEE WOMEN IN ENGINEERING AG SENDAI.....	66
IEEE YOUNG PROFESSIONALS AG SAPPORO .....	67
IEEE YOUNG PROFESSIONALS AG SENDAI .....	67
IEEE LIFE MEMBERS AG TOKYO.....	68
IEEE LIFE MEMBERS AG SOUTH AUSTRALIA .....	69
IEEE EDS MALAYSIA CHAPTER.....	70

IEEE EMBS MALAYSIA CHAPTER.....	70
IEEE PELS MALAYSIA CHAPTER .....	71
IEEE RAS MALAYSIA CHAPTER.....	71
IEEE SPS BOMBAY CHAPTER .....	72
IEEE MTT/AP/EMC ISLAMABAD JOINT CHAPTER.....	73
IEEE PELS/IES BOMBAY JOINT CHAPTER.....	73
<b>8. STUDENT BRANCH AND STUDENT CHAPTER ACTIVITIES .....</b>	<b>75</b>
IEEE AIUB STUDENT BRANCH [BANGLADESH SECTION].....	75
IEEE UCET IUB STUDENT BRANCH [BAHAWALPUR SUBSECTION].....	76
<b>9. OTHER ARTICLES .....</b>	<b>78</b>
IEEE INMIC 2020 .....	78
IEEE ICCCA 2020 .....	79
IEEE PES WOMEN IN POWER CONGRESS IN REGION 10 .....	80
WOMEN OF WISDOM (WOW) WEBINAR SERIES .....	81
VIRTUAL POCO 2020 .....	82
QUARTER TECH TALK TABLE 1.0 .....	84
<b>10. AWARDS AND FUNDING .....</b>	<b>88</b>
IEEE FELLOWS ELEVATED AS OF JANUARY 2021 - REGION 10 .....	88
IEEE REGIONAL EXEMPLARY STUDENT BRANCH AWARD 2020.....	91
IEEE DARREL CHONG STUDENT ACTIVITY AWARD 2020 .....	92
IEEE OUTSTANDING BRANCH COUNSELOR AND CHAPTER ADVISOR AWARD 2020 .....	93
IEEE GLOBAL STUDENT BRANCH WEBSITE CONTEST 2019 .....	94
LARRY K WILSON REGIONAL STUDENT VOLUNTEER AWARD 2020 .....	95
<b>CONFERENCE CALL FOR PAPERS .....</b>	<b>97</b>

# WELCOMING MESSAGES

## Message from 2019-2020 IEEE Region 10 Director

Dear All IEEE Region 10 Members,



### Happy New Year 2021!

As my two-year term as Region 10 Director reached a close at the end of 2020, I would like to express my sincere thanks to all for your collaboration and support in the operation and management of Region 10 under my directorship. The year 2019 proceeded as planned, but 2020 was assuredly like no other.

We experienced a fine start of 2020 under the leadership of President Toshio Fukuda, our first IEEE President to hail from Region 10. In January we held the Region 10 Executive Committee meeting in New Zealand and the IEEE Board of Directors Strategic Retreat in Fukuoka, Japan, without any special problems, but by the time of the Board of Directors meeting that convened in Boston in February we were wearing masks and using disinfectant.

The situation had worsened by March so that all events were moved online, including the Region 10 AGM, three flagship conferences, and our biennial SYWL Congress. We have been learning how effectively to conduct online meetings and conferences, developing skills whose usefulness is I think bound to extend beyond the immediate pandemic.

Furthermore, even with COVID-19 expanding, Region 10 is still growing. One new Section (Vizag Bay), five new Subsections (Quetta, Laos, North Karnataka, Rourkela, and Mysore), several Affinity Groups, and numerous Chapters and Student Branches were all formed during 2020.

IEEE's Member and Geographic Activities Board has been discussing regional realignment since 2018. Region 8 (Europe, Middle East, and Africa) and Region 10 (Asia-Pacific) proposed to split their present regions into two each, as their respective memberships comprise 18% and 32%, of the IEEE total. The MGA Board unanimously agreed to six (6) Regions in the Americas and four (4) Regions in Eurasia, Africa, and Oceania. However, among our overall membership that decision does not necessarily represent everyone's first choice.

This year we shall move further in discussing how best to determine new regional borders. In Region 10, for example, we have been considering a split of the current Region 10 into two. I have great confidence in the leadership of my immediate successors: Deepak Mathur, 2021-22 Director, and Lance Fung, 2023-24 Director, and hope we can reach agreement on the two new Regions for Asia-Pacific in the very near future.

Meanwhile, please continue to devise and participate in vibrant and innovative IEEE (online) activities, and keep staying safe and healthy!

With much gratitude for the past two years,

Akinori Nishihara  
2019-2020 IEEE Region 10 Director

## Message from 2021-2022 IEEE Region 10 Director



### Happy New Year!

Wish 2021 brings hope, health, and prosperity to you and your loved ones.

There are many lessons to learn from 2020, which was unprecedented and very challenging. But, challenges bring opportunities. It is my great honour and privilege to serve Region 10 as Director for 2021-2022. I take this opportunity to thank you all for your kind support and electing me to this position.

I would like to congratulate the leadership of Prof. Akinori Nishihara, which was exemplary and outstanding. He led the 2019-2020 Region 10 team in an excellent way and provided immense value added member engagement during this time of pandemic.

As we march towards 2021, we are fully aware of the challenges brought forward by the pandemic; and we have to look for opportunities in these challenges. IEEE is a 'member centric, volunteer driven and staff supported organization'. We saw its true reflection during 2020, where volunteers and staffs together made wonderful opportunities available to its members. Numerous events – webinars, conferences, congresses, competitions, awards ceremonies and many other activities were conducted in the virtual format.

IEEE also took very prompt initiative and created COVID-19 Resources for members in the form of products, services, courses, and tools from across IEEE to help members and their families. All our volunteers and staffs deserve sincere appreciation for this. I am truly grateful to them for their selfless contributions.

In 2021, it seems, we would be continuing our activities in virtual mode, at least for quite some time. However, it is also pragmatic to see that at some places activities are getting started in a hybrid mode. I too wish that the pandemic gets over soon and we are able to start our in-person events.

Irrespective of how 2021 pans out, the Region 10 team will be committed to go full gear forward with our goals. Following are our thrust areas and major priorities for 2021-2022.

### Thrust areas:

**Membership Activities:** Member retention and continuation of students to Young Professionals.

**Technical Activities:** Section-Chapter collaborative programs, conference quality and industry engagements.

**Professional Activities:** Entrepreneurship and career advancement programs.

### Major priorities:

- Conferences and its quality
- Member value, member engagement and member satisfaction through collaborative programs
- Industry academia partnership
- Diversity: more leadership and volunteering opportunities for YP and women.
- Programs for students and YP, where YP helps students in their career growth.
- Sustainable 'Humanitarian Technology' projects.
- Promote 'Reaching Locals' initiative.

Apart from these, if you believe that there need to be any other specific areas of focus, please feel free to reach out to me personally. I am open to your ideas and feedback, and look forward to your continued support in the coming year, to propagate our combined vision of "Joy of Volunteering".

Wishing you once again a very happy and promising time ahead.

Deepak Mathur  
2021-2022 Region 10 Director

## Message from IEEE Region 10 Newsletter Coordinator

Dear Region 10 Members,

Happy New Year! It is my pleasure to welcome you to the January 2021 issue of IEEE Region 10 Newsletter. It is two years since I first took over as the chair for the IEEE Region 10 Newsletter Committee, and it has been a wonderful experience for me to work with my Newsletter Committee members as well as the Region 10 ExComm members in producing eight (8) newsletter issues throughout the two years. I am very thankful to the 2019-2020 Region 10 Director, Akinori Nishihara, for giving me the chance to helm the committee and contribute to IEEE at the regional level. And thank you also to the new Region 10 Director for 2021-2022, Deepak Mathur, for entrusting me again to continue leading the Newsletter Committee under his leadership for the next 2 years.



This first newsletter issue of the year features excellent content for your reading pleasure. As you may have been aware, we started our technical column last year with articles from the winners of the R10 Postgraduate Research Paper Contest. This year, we plan to expand the technical content by inviting renowned researchers to write on the latest development on various research fields within the scope of IEEE. For this issue, we are honored to have two (2) of our IEEE Fellows, Byung-Gook Park and Seishi Takamura, to write about their latest work on *Neuromorphic System and Integrated Circuits* and *Image/Video Coding Technology for IoT Era*, respectively. This issue also features special report on three (3) flagship R10 events conducted during the last quarter of 2020, namely the IEEE Region 10 Conference (TENCON2020), IEEE R10 Humanitarian Technology Conference (R10HTC2020), and IEEE R10 Student, Young Professionals, Women in Engineering, and Life Members Congress (SYWL2020), all of which were carried out virtually.

The newsletter continues with another five (5) *Personalities of the Month* as well as five (5) *Organizational Units of the Month* in this edition. We received many requests from Student Branches across the region to feature in our *Student Branch of the Month* column, that we decided to feature two (2) of them in this issue. Besides, we also continue to feature another one of our COVID-19 heroes in the *COVID-19 Personality of the Month* column. This time, the honor goes to the team from Universiti Teknologi Malaysia from the Malaysia Section for their effort in studying communication effectiveness at construction sites during COVID-19 outbreak in Malaysia. And we are very glad to continue receiving tremendous support from various Sections, Chapters, Affinity Groups, and Student Branches/Chapters across Region 10 in reporting IEEE activities occurring within their unit. We thank all these volunteers for their contributions to this newsletter.

And I would like to take this opportunity to personally thank and honor my R10 Newsletter Committee members (Prof. Fattah, Prof. Prashant, Redwan, Wathmini, Naila and Nabeel) for their incredible hard work and efforts in assisting me for the last 2 years.

And to all readers, enjoy the newsletter, and stay safe wherever you are.

Mohammad Faizal Ahmad Fauzi  
Chair, IEEE R10 Newsletter Committee



# SPECIAL REPORTS





# 1. SPECIAL REPORTS ON R10 FLAGSHIP EVENTS



## IEEE Region 10 Conference 2020 (TENCON2020)

16<sup>th</sup> – 19<sup>th</sup> November 2020, Virtual Osaka, Japan

**Written by: Mohammad Faizal Ahmad Fauzi, Chair for the R10 Newsletter Committee**

With the theme *Advancing Technologies for Sustainable Development Goals to Transform Our World*, the 2020 IEEE Region 10 Conference (TENCON2020) were successfully held from 16<sup>th</sup> to 19<sup>th</sup> November 2020 by the IEEE Japan Council. The 35<sup>th</sup> edition of TENCON was initially planned as physical event to held in Osaka, Japan, but due to the COVID19 pandemic, it was changed to a fully virtual event instead using the Zoom platform. The conference consists of keynote speeches, special sessions, invited sessions, as well as the regular parallel sessions. 257 papers were presented throughout 3 days, divided into 46 tracks which covers various electrical and electronic engineering disciplines.

TENCON2020 Tracks	
<i>Machine Learning, Cloud and Data Analytics (12)</i>	<i>Signal and Image Processing (6)</i>
<i>Power &amp; Energy (6)</i>	<i>Circuits and Systems (4)</i>
<i>Wireless Communications &amp; Networks (4)</i>	<i>Robotics, Control Systems &amp; Theory (3)</i>
<i>Multimedia Engineering (3)</i>	<i>Computer Architecture &amp; Systems (2)</i>
<i>Biomedical Engineering (1)</i>	<i>Antenna &amp; Microwave (1)</i>
<i>Devices, Materials &amp; Processing (1)</i>	<i>Social Implications of Technology (1)</i>
<i>Software &amp; Database Systems; Photonics; Disasters and Humanitarian Technology (1)</i>	<i>Engineering Education &amp; Engineering Management (1)</i>

The conference started from Tuesday 17<sup>th</sup> November 2020. TENCON2020 General Chair, Takao Onoye and Honorary Chair, Isao Shirakawa welcomed all participants to the conference. The Technical Program Chair, Minoru Okada then presented the technical report, where he informed that the conference received 426 papers submission from 22 countries. After careful review, 289 papers were accepted for presentation (67% acceptance rate) at the conference, in which 257 papers were eventually presented. The highest number of submission comes from India which made up 31.3% of the total submission, followed by the Philippines (23.3%) and Japan (12.9%).

The opening ceremony was proceeded with the address by IEEE Region 10 Director, Akinori Nishihara, and IEEE President, Toshio Fukuda. In the afternoon session, Md. Altaf-Ul-Amin from Nara Institute of Science and Technology delivered the first plenary talk on *Applications of KNApSack Database and DPPlus Algorithm: Plants to Metabolites to Target Proteins in the Context of Jamu Medicines and IBD Gene Prediction*. The first day also saw 16 regular sessions as well as 2 special sessions (*Recent Advances*

on Autonomous Mobile Robots) conducted in 6 parallel tracks. All presentations were pre-recorded with the presenter taking up the questions live following their played-back presentation.



The second day saw another keynote speech delivered by Keisuke Fujii from Osaka University, where he discussed the topic on *Quantum Computing: State of the Art and Prospects*. Besides, it also features the first invited session on IEEE Region 10 Special Industry Track. Welcomed by the Industry Relations Chair, Chris Lee and chaired by Sugie Toshihiko, the session lined up 4 prominent speakers namely Kazuo Yano, Kazuko Ishikawa, Stefan Winkler and Davis Chen. The second day also saw a session specially conducted for the winners of the 2020 IEEE R10 Postgraduate Research Paper Contest to share their excellent research work. Another 16 regular sessions as well as a special session on *New Trends of Biometrics* rounded up the second day of the conference.



The third and final day of the conference saw another 2 invited sessions on *R10 YPC-PAC Workshop: How to Plan and Manage Online Contest*, organized with the support of the R10 Young Professionals Committee (YPC), and *Engaging More Women in Technical Activities: Following SPS and PES Models*, with the support of the R10 WIE Committee. The YPC-PAC workshop, chaired by R10 YPC Chair, Takuo Suzuki, featured 3 excellent young speakers, namely Takashi Yoshida, Shravan Kumar Kalyankar and Navaneethakrishnan Ramanathan, sharing their experiences in managing online contests and discussing the establishment of a fair and adequate judging committee.



The WIE track, co-chaired by R10 WIEC Chair, Emi Yano and IEEE SPS WISP & 2017-20 IEEE PES WIP R10 Representative, Celia Shahnaz, lined up 6 prominent women speakers including the 2021 IEEE WIE Chair, Jenifer Castillo; 2021 IEEE Signal Processing Society President, Athina Petropulu; and 2021 IEEE Power and Energy Society President, Jessica Bian. Celia Shahnaz, Ruomei Li and G. Bhuvaneswari completes the list of excellent speakers for the session. In this special WIE track, participants found motivation and realized the value of WIE utilizing the advantage of virtual mode while learning the opportunities to engage in different technical societies, such as SPS and PES. Another 14 regular sessions were carried out before the closing ceremony brought the 35<sup>th</sup> edition of TENCON to an end.



Four papers were selected for TENCON2020 Student Paper Awards; 2 from special sessions, and another 2 from the regular sessions. The four papers are:

#### Special Session:

1. Improved Double-Tree RRT\* Algorithm for Efficient Path Planning of Mobile Robots, *Liquan Jiang, Shuting Wang, Jie Meng, Xiaolong Zhang, Yuanlong Xie*
2. An Efficient and Robust Approach to Solve the Kidnapped Robot Problem Considering Time Variation, *Jie Meng, Shuting Wang, Gen Li, Liquan Jiang, Yuanlong Xie, Haodong Sun, Chao Liu*

#### Regular Session:

1. Individual Learning Effectiveness Based on Cognitive Taxonomies and Constructive Alignment, *Phat Huu Nguyen, Preecha Tangworakitthaworn, Lester Gilbert*
2. A Concentric Double-Ring Resonator Based Plasmonic Refractive Index Sensor with Glucose Sensing Capability, *Md. Farhad Hassan, Infiter Tathfif, Mohammed Radoan, Rakibul Hasan Sagor*

Overall the 2020 edition of TENCON, the flagship conference of IEEE Region 10, was very successful despite the virtual mode, with 534 total number of participants (i.e. Zoom unique sessions). Well done to the organizing team from the Japan Council, led by Prof. Takao Onoye. See you in Auckland, New Zealand in December 2021 for the 36<sup>th</sup> TENCON!



## IEEE R10 Humanitarian Technology Conference 2020 (R10HTC 2020)

1<sup>st</sup> – 3<sup>rd</sup> December 2020, Virtual Kuching, Sarawak, Malaysia

Written by: **Mohammad Faizal Ahmad Fauzi**, Chair for the R10 Newsletter Committee & General Co-Chair for IEEE R10HTC2020

Like the other two flagship Region 10 conferences, TENCON2020 and TENSYP2020, the organizing committee for R10HTC2020 decided to conduct the conference as a fully virtual event this year due to COVID19 pandemic. With the theme *Digital Ecosystem for Humanity*, the 8<sup>th</sup> edition of the R10HTC series were successfully hosted by the IEEE Sarawak Subsection on a Zoom online meeting platform from 30<sup>th</sup> November to 3<sup>rd</sup> December 2020. It is a historic moment as this was the first time a Subsection has been entrusted to host a flagship Region 10 conference. The conference is made up of rich variety of events including keynote and invited speeches, regular and special sessions, as well as workshop.

Besides, in conjunction with the conference, IEEE Malaysia Section conducted the Panel of Conference Organizers Workshop (POCO), with sponsorship from Region 10. In total, 87 papers from different aspects of humanitarian technologies were presented in 16 regular sessions and 3 special sessions throughout the conference. The regular sessions cover topics such as *Electrical & Electronic Engineering, Computing and Information Technology, Artificial Intelligence, Healthcare & Biomedical Engineering, Power & Energy, Education, Food Science & Agriculture, Smart City & Smart Village, and Industrial Revolution 4.0*. The three special sessions were on *Integrating Humanity into Industry 4.0, Social Innovation and Creativity during COVID-19, and Technology for Ageing Population*.

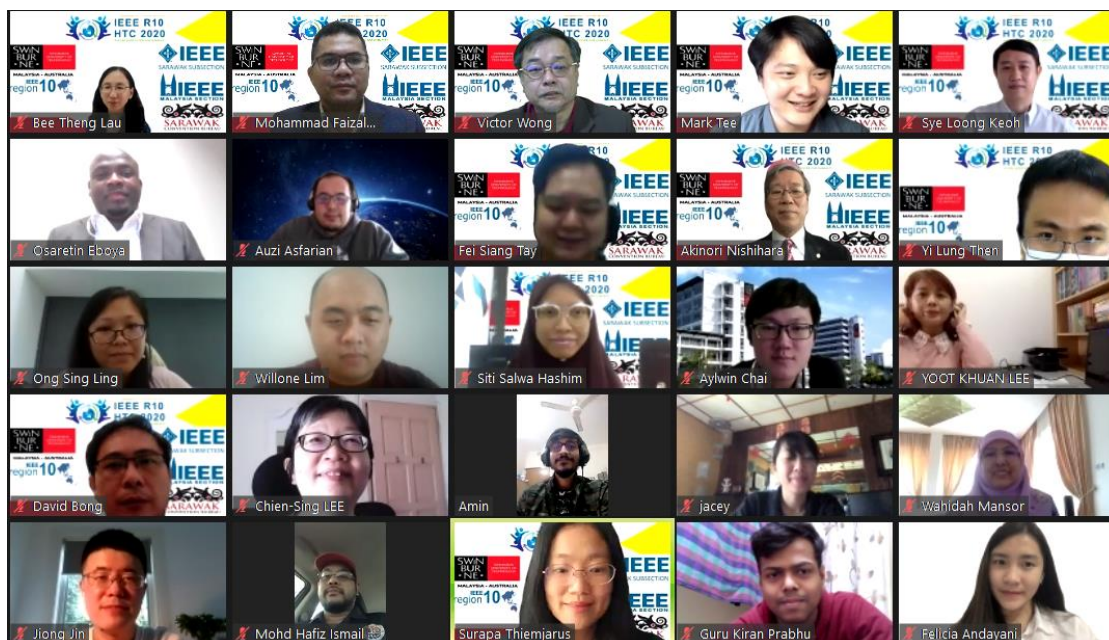

While the conference proper only started on Tuesday 1<sup>st</sup> December, the first day was filled with technical workshop, special session on humanitarian technology, as well as POCO workshop. The workshop on *Data Analytics Using Machine Learning Techniques* were facilitated by Rathimala Kannan. The workshop is especially relevant to those interested in developing business data analytical to make informed business decisions. The special session on humanitarian technology consists of three lectures delivered by prominent speakers in the area. Celia Shahnaz delivered a talk on *Humanitarian Activities and Technologies during Covid-19 Pandemic in Asia Pacific Region*, while local speaker Then Yi Lung discussed the *Activities of IEEE Sarawak SIGHT*. The final lecture of the special session was given by Jing Dong (R10 HAC Chair) and Shaikh Fattah on the *Introduction for IEEE SIGHT; Effective Community Engagement to Design Sustainable Humanitarian Projects to Combat COVID19*. Finally, the POCO workshop featured 12 speakers discussing conference leadership practices, challenges in the conference landscape, envisioning the future, and launching new conference initiatives. Separate report on POCO2020 is included in the Other Articles section of the newsletter.

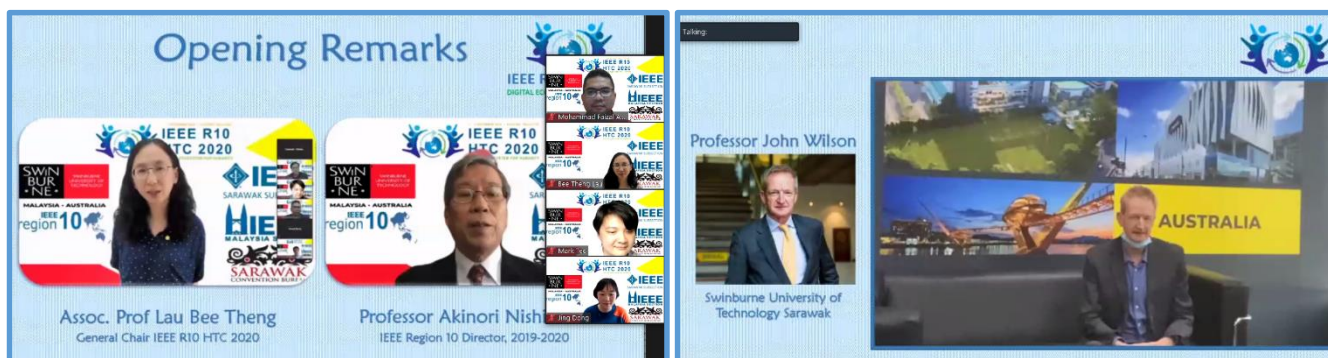

The first day of the conference proper started with a brief opening ceremony where all participants were welcomed by the IEEE Sarawak Subsection Chair, Victor Wong. R10HTC2020 General Co-Chair, Mohammad Faizal Ahmad Fauzi then shared with the audiences how the Sarawak Subsection, which was only formed in 2015, were able to convince Region 10 to entrust the young Subsection to host one of its flagship conferences. Technical Program Chair, David Bong then shared the technical review aspect of this year's conference. Overall 154 submissions were received from 12 countries, with 26% of the papers from Malaysia. After rigorous review process, 108 papers were accepted (acceptance rate of 70%), and 87 papers registered for presentation at the conference. The conference General Chair, Lau Bee Theng then proceeded to officially open the conference, before R10 Director, Akinori Nishihara gave an update on IEEE Region 10 activities and initiatives. The conference is also honored to have Professor John Wilson, the Deputy Vice-Chancellor and Chief Executive Officer of Swinburne University of Technology Sarawak to grace the event via a pre-recorded video.

**Internet-of-Things (IoT): Accelerating the Smart City Revolution**  
Sye Loong Keoh, University of Glasgow

**SURAPA THIEMJARUS, MACHINE LEARNING & ANALYTICS EXPERT**

**Education:**

- BSc. in Information Technology (First honor, gold medal), Srinthorn International Institute of Technology, Thammasat University, Thailand
- MSc. in Advanced Computing (Thesis with distinction), Imperial College London, UK
- MPhil. in Speech, Text Processing and Internet Technology, University of Cambridge, UK

- Surapa is a researcher from the Health Innovation and Information Research Team (HI), Assistive Technology and Medical Devices Research Center (A-MED), Thailand.
- Her research interests include machine learning and building innovative technologies and IoT solutions for health industries, elderlies and people with disabilities. She is experienced with intelligent analysis of multimodal data types including text, speech, image, video and sensor.
- She has authored/co-authored over 70 scientific publications, 3 book chapters, and filed 11 national/international patents.
- Prior to joining NSTDA, she was an assistant professor at the School of ICT, SIIT, Thammasat University. Teaching topics include Data Warehouse and Data Mining, Knowledge Management and Knowledge Discovery, Pattern Recognition, Artificial Intelligence and Programming.
- She worked as a consultant for local and international companies in the area of data analytics for healthcare, healthcare insurance and Big Data.
- She served as a managing editor and is an associate editor of the IEEE Journal of Biomedical and Health Informatics (J-BHI).
- She is a recipient of Ananda Mahidol scholarship and received several awards including "Telecom Prototype Award" from the Telecommunications Research and Industrial Development Institute (Finalist), best paper awards from several

The first keynote of the conference was delivered by Sye Loong Keoh from the University of Glasgow, Singapore, with the title *Internet-of-Things (IoT): Accelerating the Smart City Revolution*. 38 oral

presentations, divided into 8 regular sessions, rounded up the first day of the conference. To ensure smooth run of the conference, all presentations were pre-recorded with the presenter taking up live questions following their respective played-back presentations.

The second day of the conference started with another keynote speech on *A Journey Towards Creating Impact with Technology for People*, delivered by Surapa Thiemjarus from the Assistive Technology and Medical Devices Research Center (A-MED), National Science and Technology Development Agency (NSTDA), Thailand. Her talk is followed by an invited talk on Humanitarian Activities and Technologies for the 21<sup>st</sup> Century, given by Supavadee Aramvith. Another 34 presentations were carried out in 8 oral sessions to complete the proceedings for the second day.

The third and final day of the conference were scheduled for special sessions. The three special sessions on *Integrating Humanity into Industry 4.0*, *Social Innovation and Creativity during COVID-19*, and *Technology for Ageing Population* were carried out concurrently with 15 presentations. Before the special sessions, the third day started with the final keynote by Jiong Jin from Swinburne University of Technology, Melbourne who delivered a talk on *Energy Sustainable Fog Information System for Infrastructure-less*.

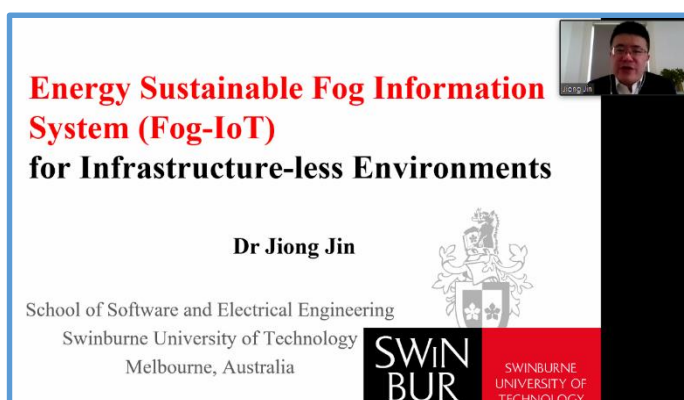

This is followed by the final invited talk by Lance Fung, the 2021-2022 R10 Director-Elect on *Educational Activities and Digital Technology for Humanity and Life-Long Learning*.

The conference concluded with a closing ceremony officiated by Jing Dong, IEEE Region 10 HC Chair. During the closing ceremony, 5 best paper awards were announced:

#### Best Paper Award

1. Integrating Humanitarian Technology in Computer Science Education to Internalize Independent Campus Policy: A Case in IPB University, *Auzi Asfarian, Dean Apriana Ramadhan, Firman Ardiansyah*
2. Effectiveness of an Automated Reading Tutor Design for Filipino Speaking Children, *Ronald Pascual*

#### Best Student Paper Award

1. A Preliminary Study on Effectiveness of an Ingeniously Developed Wearable Assistive Device, *Vishnu Rajendran S, Harish Mohan T, Bhavani Rao R, Jogesh S Nanda, Karishma Sebastian*
2. Feature Selection Based Twin-Support Vector Machine for the diagnosis of Parkinson's Disease, *Surendrabikram Thapa, Surabhi Adhikari, Awishkar Ghimire, Anshuman Aditya*
3. Towards an Efficient and Secure Blood Bank Management System, *W.A.D.T.L. Wijayaweera, P.A.J. Sanadaruwana, U.D.L. Dolapihilla, D.W.N.R. Karunathilaka, W. H. Rankothge, N. Gamage*

In conjunction with IEEE R10HTC 2020, the Sarawak Subsection as the host was also awarded 2 grants from IEEE R10 TENHUMCH and IEEE HAC to conduct three humanitarian projects in Sarawak (<https://r10htc2020.org/projects>).

## Project 1 – Community Empowerment: Promoting Safe and Sustainable Food Production

Food security in a community exists when all people at all times have both physical and economic access to sufficient food to meet their dietary needs for productive and healthy lives. The pandemic caused by the new coronavirus COVID-19 threatened food shortages due to supply chain disruption and labor shortages. Many households are vulnerable to the impact of a severe pandemic due to the impacts on the economic and social systems. This Humanitarian Engineering project aims to boost the local communities' resilience of food supplies (i.e., enhance food security) through encouraging the establishment of family/kitchen gardens with the use of organic fertilizer, compost.



As our population increases and farmland disappears to commercial and residential development, it is becoming increasingly important to produce food, clothing, forest and floral products on less land for more people. Fertilizer plays a crucial role in improving agriculture efficiency, in particular organic

fertilizer to promote food production in an ecologically sound way. The five-week project successfully reached out to over 50 local community members in the sub-urban areas of Kuching, Sarawak. Virtual workshops were conducted to educate and guide participants on systematic and informed home composting of kitchen waste. Each participating household was provided with a set of composting kit and on-site guidance was given on the setting up of the composting system. Swinburne University Sarawak researchers guided the participants throughout the project via virtual platforms on the know-hows and technical challenges of the composting process.

## Project 2 – Enhancing Humanitarian Engineering Within the Vulnerable Communities

Knowledge of household on clean water and hygiene is important particularly in vulnerable communities where water supply is insufficient and highly contaminated. Water scarcity and inferior water quality could significantly affect the health and well-being of children. IEEE in collaboration with Swinburne University of



Technology Sarawak and local NGO, organized a humanitarian project for vulnerable communities in conjunction with the IEEE Region 10 Humanitarian Technologies Conference 2020 held virtually in Kuching. The project was spearhead by Ir. Dr. Angelia Liew, Dr. Hadi Nabipour, Dr. Tay Fei Siang, Mohd Elfy Mersal, Dr. Lau Bee Theng (General Chair for IEEE R10 HTC2020) and student volunteers from various engineering background. The team visited a small squatter village near Lorong Chawan, just a kilometre from the Kuching

city center on 20<sup>th</sup> December 2020. The 51 households of about 230 villagers including 61 children mostly collect their drinking water from a standpipe.

The aims of the project were to bring basic clean water knowledge alongside awareness of the Covid-19 pandemic within vulnerable communities and to encourage our engineering students to contribute to building a more sustainable, stable, and equitable world, to promote creativity and problem-solving skills to engineer inexpensive solutions for real-world challenges. The team successfully conducted three workshops on the importance of clean water and ways to build homemade water filter, for 45 children. Each child was given a set of water filtration kit to try at home. Also distributed were Pack of Hope stationaries and Pack of Love Christmas goodies for each child, and masks and sanitisers for each household. The project serves as a platform for humanitarian efforts and provides a rewarding and enriching experience for the student volunteers, boosting their personal development and their understanding of the challenges facing the world today. The project received a USD1000 fund awarded by the IEEE Humanitarian Activities Committee Events Fund in conjunction with the conference.

### Project 3 – Tackling Challenges to Water-Energy-Food Security (WEF) Nexus

The Water-Energy-Food (WEF) nexus is a framework used to show the inter-connection between these three resource sectors. According to the Population Division of the United Nations Department of Economic and Social Affairs, the global population is expected to reach 9.7 billion in 2050 and could peak at 11 billion by the end of the 21st century. As the global population continue to increase, issues such as food scarcity, availability of freshwater and energy shortage would become more prominent global challenges. IEEE Sarawak Subsection decided to undertake this humanitarian project to raise the awareness level for the WEF nexus among Malaysian students. As Malaysia is a country that is endowed with stable governance and rich natural resources and biodiversity, Malaysian students rarely venture to contemplate on the potential issue of resource scarcity in the future.

It is believed that educating Malaysian students on the WEF nexus is an important step to starting a student discourse on the challenges and potential solutions on the WEF Nexus in the coming years. The project reached out to 45 students through a series of coding and electronics bootcamps held in three main cities in Sarawak i.e. Kuching, Sibu



and Miri in December 2020. The program received an award of USD4000 fund from the IEEE Humanitarian Activities Committee 2020. The project was initiated by Associate Professor Lau Bee Theng, in conjunction with the IEEE Region 10 International Humanitarian Technology Conference 2020, that was co-organized with Swinburne University, Sarawak. The modules for the workshop were developed by Dr. Xavier Chee from the biotechnology program.



Well done to the organizing team from the Sarawak Subsection, the first Subsection to host a flagship Region 10 conference!



# IEEE R10 SYWL Virtual Congress 2020 (SYWL2020)

19<sup>th</sup> September to 4<sup>th</sup> October 2020

Written by: Zia Ahmed, General Chair for R10 SYWL2020

The IEEE Region 10 Students, Young Professional, Women in Engineering and Life Members (R10 SYWL) Congress is a flagship R10 biennial event, which provides a platform for IEEE volunteers from Sections across the region to learn and train for enhancement of their personal and professional skills, interact with each other and network to learn best practices. The congress, originally scheduled to be held at Bangkok, Thailand in September, 2020, was cancelled due to the COVID-19 restrictions and the R10 leadership decided to hold the congress virtually. As engineers and scientists are playing a key role in the fight against COVID-19 pandemic, the theme selected for the Virtual R10 SYWL Congress 2020 was **“Pandemic to Opportunity – Collaborative Leadership Towards Technology Advancement for Humanity”**. One of the main objectives of organizing the congress was to explore new horizons of collaborations and moving forward in advancing technology during and after the COVID-19 pandemic.

The R10 SYWL Virtual Congress was conducted over 16 days, from 19<sup>th</sup> September to 4<sup>th</sup> October 2020, via WebEx sessions and live streaming on Facebook. More than fifty volunteers helped to successfully conduct the R10 SYWL Virtual Congress 2020 consisting of four tracks (Students, Young Professionals, Women in Engineering and Life Members) and three public sessions (Educational Activities, HAC and IEEE SA). 120 speakers, including 44 female speakers, delivered keynote speeches, technical talks and participated in panel discussions. The ratio between academia/non-academia speakers was about 66:59.

The R10 SYWL Virtual Congress 2020 was launched with an Opening Ceremony on 19<sup>th</sup> September 2020. R10 SYWL General Chair Dr. Zia Ahmed welcomed IEEE President Professor Toshio Fukuda, MGA Vice President Prof. Kukjin Chun, R10 Director Prof. Akinori Nishihara and R10 Director-Elect Deepak Mathur to the congress. Prof. Fukuda and Prof. Nishihara delivered the keynote addresses. The four Track Chairs also addressed the participants and outlined their program for the congress.

During the 16-day congress there were a total of 25 sessions, consisting of opening ceremony, 7 sessions under the Students Track, 4 sessions under the WIE Track, 4 sessions of YP Track and 5 sessions of LM Track, 3 special sessions related to Educational Activities, Humanitarian Activities, and IEEE Standard Association and finally a closing ceremony. There were a total of 1,362 registered participants nominated by Sections for attending the online WebEx session. Most of the sessions were also lived streamed and archived via R10 Facebook SYWL page, which attracted more than 10,000 additional participants. There were also 5 contests and numerous networking sessions and a cultural performance show at the closing ceremony.

## Students Activities Track

Student Track consisted of Seven Sessions, delivered by 37 globally recognized speakers/moderators. Each session consisted of bonus networking sessions for attendees. All sessions were partnered with 78 Student Branches from R10. The sessions were in collaboration with IEEE Industry Engagement Society, IEEE Entrepreneurship, IEEE Eta Kappa Nu Society, IEEE Industry Relations Society, IEEE Volunteer Leadership Program and IEEE Centre for Leadership Excellence.

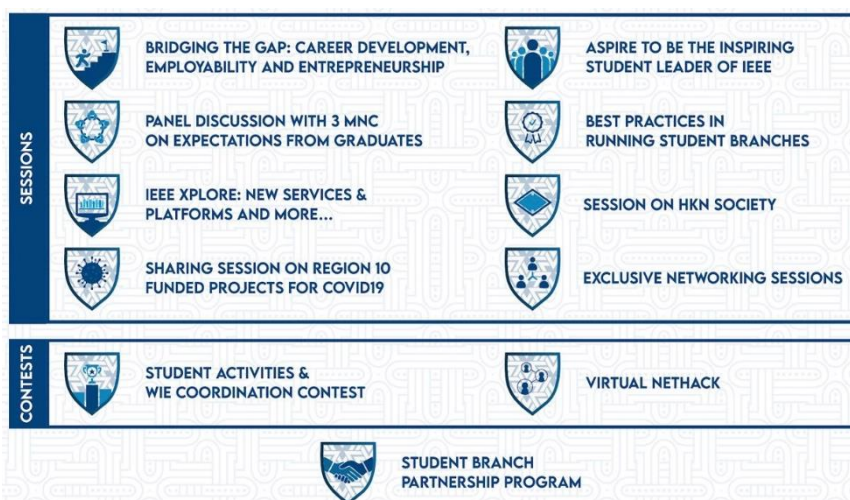

R10 Student Activities Committee launched the Student Branch Partnership Program to provide an opportunity for Student Branches to partner with the R10 SYWL Virtual Congress so as to maximize students' participation in the student-oriented programs. The program partnered with 78 Student Branches across 19 Sections covering 8 countries within R10 and enormously boosted students' participation in a plethora of interactive activities spread throughout the 2 weeks of the congress. The partnered SBs contributed by initiating through screening/broadcasting student track sessions to extended audiences within their Student Branch community.

The best part of R10 SYWL Congress was the opportunity of connecting to a broader IEEE member network. As such, exclusive virtual networking sessions were designed at the end of every Student Track session which allowed to foster a much stronger web of networks at various OU and geographic levels i.e. Student Branches, SB Technical Society Chapters, Affinity Groups, Sections and across countries in the Asia-Pacific region. The purpose of organizing the networking activities was for the participants to mingle with each other, widen their connections, learn from each other, and have fun while attending a virtual congress. Interactive games such as the Puzzles and Bingo with IEEE were organized to make the sessions much fun and engaging. Moreover, the speakers and delegates also conducted informal sharing sessions about best practices when volunteering and about IEEE student member benefits. Surprise prizes were presented to the most engaged student attendees of the congress. Mayesha Tafannum, who was one of active delegates from Bangladesh Section and one of the Networking Surprise Prize winners, mentioned that *"This experience is incredible! From being able to listen to prominent speakers on wonderful topics to attending the networking sessions! The best part was the networking sessions where we were able to connect with different members from different sections of R10. Attended each of them and getting to know new people across our region and it felt amazing"*.

Exciting student contests were also held throughout the congress. The joint contest by Student Activities & WIE Committees gave an opportunity to SBs/SAC/WIEs to showcase the best practices and activities to improve membership retention and development. The contest was sponsored by Life Member Funding for student activities. The contest aimed for giving recognition to the SBs/SAC/WIEs groups at Student and Section WIE AG levels. The theme of the contest was *"Engage and Educate"*. The Student Branch, Section SAC and Section WIE Affinity Groups were invited to participate in the contest and showcase the activities that they had organized so as to engage and educate IEEE members through creative posters. The 5 shortlisted best contestants of each category underwent a Facebook poster contest and a 3-min LIVE video presentation. The winners were:

Category	Winner (Prize: USD 500)	Runner-Up (Prize: USD 250)
Section SAC	IEEE Malaysia Section	IEEE Bombay Section
Student Branch	College of Engineering Karunagappally	Silver Oak College of Engineering & Tech
Section WIE	IEEE Bangalore Section WIE	IEEE Gujarat Section WIE
Student Branch WIE	IEEE BVP SB WIE	The NorthCap University SB WIE



The contest was also a great platform to recognize active SBs/SAC/WIEs of IEEE Region 10 and provided an opportunity to showcase their best practices and activities to IEEE Region 10 Top Leadership.

The R10 SYWLC Student Track Virtual Nethack aimed to improve participants’ communication and networking skills to a wider online viewing community. The contest facilitated the recognition of these networking skills and to learn the best practices and activities organized in other SB/Section/Region. The theme of the contest was to promote “Virtual Networking”. The competition was conducted through team-building activities such as virtual meets, team tasks and quizzes. All members of the top 3 teams received USD27 IEEE membership subscription and the winners were:

Rank	Team’s Name	Team Members (Section)
1	Mars	Rabbia Saleem (Australian Capital Territory) Satyaki Banik (Bangladesh) Nayab Ali (Islamabad) Akash Nair (Kerala) Khurram Waqas Malik (Lahore)
2	Uranus	Minahil Ali (Islamabad) Kevin Hung (Hong Kong) Adhithyaa G. (Kerala) M. Abdul Rehman (Lahore) Nishita Kalpesh Pali (Pune)
3	Saturn	Rashid Noor (Islamabad) Mengke Li (Hong Kong) Gaius G D’cruz (Kerala) Mujtaba Ahmad Khan (Lahore) Siddharth Saoji (Pune)



Group photo taken at Final Round Judging LIVE Presentations

### Young Professionals (YP) Track

The YP Track had 4 sessions and 1 contest. All sessions were well-attended via WebEx by registered delegates and a large number of members joined the sessions through live streaming of Facebook.

In the first session, Flavia Dinca, IEEE YP Chair introduced the IEEE Volunteering Platform, a new IEEE web system for volunteers. The history of development and some key features were explained. A live demonstration was also conducted to show how to use it, and questions from the floor were answered using a test user. The second session was about elevation to Senior Membership in which Mr. Amarnath Raja provided practical advice for becoming an IEEE Senior Member. Three more speakers shared their experience about why they became an IEEE Senior Member and what kind of preparation was needed.

The third session entitled “Entrepreneurship and Industry Engagement” was jointly held with the R10 Industry Relations Committee for panel discussion on cutting-edge technologies, IoT and 5G. Participants were informed how to connect such technologies to business as a start-up. One young entrepreneur as a keynote speaker shared the basics of entrepreneurship and experience of transitioning from a PhD student into an entrepreneur. Other invited keynote speakers highlighted challenges and opportunities related to the Internet of Things and 5G Technology.

The fourth YP session provided an opportunity to exchange information about activities of young professionals amidst the COVID-19 pandemic. In this YP session, the representatives of Section YP Affinity

Groups shared their best practices with YP volunteers. The session focused on how to cope with pandemic crisis and make YP activity plans adjusting to the “new normal.”

The YP Track contest offered a networking opportunity for Young Professionals and strengthened YPs’ network on Facebook to communicate directly and casually. Each participant submitted his or her one-page proposal to the Facebook Group for this contest, and all the participants evaluated posts with each other. Full contest details are available at: <https://www.facebook.com/groups/334250581186452>.



Winners’ one-page proposals of YP pitch contest.

## Women In Engineering Track

R10 WIE Committee organized 4 sessions, some of which were exclusively designed for female engineers and professions to discuss strategies to deal with issues relevant to their career, challenges of work-life balance and scarcity of female leadership in academia and industry. In one session “WIE Best Practices, Challenges and Opportunities”, distinguished female speakers discussed best practices, challenges and opportunities from their professional career and how IEEE had helped them. Throughout the congress WIE volunteers were grouped in various teams to deliberate on key goals of WIE – Retention, Recognition, Mentorship, Leadership, Collaboration and came up with recommendations for R10 to implement in its WIE program. The exercise created an opportunity for discussion to inspire delegates and live audience for innovation, facilitated knowledge sharing and provided support through highly interactive sessions designed to initiate discussion and foster collaboration.

The session on Career Development for Mid-Career WIE focused on introducing professional career development skills for women who are in the middle of their careers. It aimed to enable women engineers and researchers to reach their full potential and shine. Dr. Lisa Lazareck-Asunta, Global WIE Chair and R10 Director, Prof. Akinori Nishihara also joined the session as panelists. The expert panel also discussed how to support and encourage the next generation of the WIE members to move forward together.

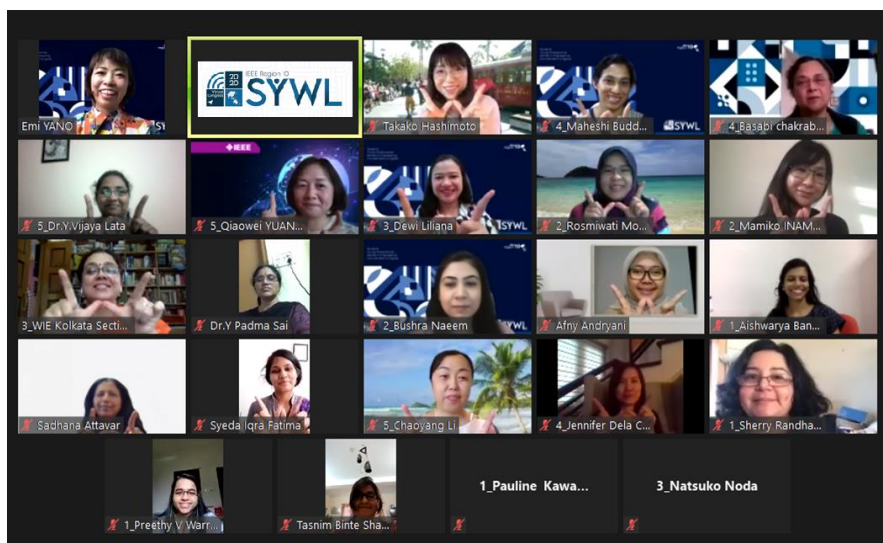

## Life Members Track

Life Members (LM) Track achieved a new record of LMAG Chairs engagement across R10 for the first time. The IEEE R10 SYWL Virtual Congress provided a platform to Life Members to share their experience and expertise with fellow LMs and live audience. In addition, LMs were exposed to new technologies, IEEE vTools and Collabratic for continuing to pursue their technical and social interests. LM delegates and online audience were also informed about the significance of IEEE milestone program and the process of applying

for milestone recognition. R10 LM Committee also organized a photography competition for Life Member delegates. The following LM sessions were organized during the 2020 R10 SYWL Virtual Congress.

**LM Session 1: Sharing Success Stories** – The session was held on 27<sup>th</sup> September 2020 and moderated by Dr. Leon Lei (Hong Kong Section) and Prof. Jong Chang Yi (Seoul Section). The following members shared their success story with participants:

- Prof. Nim Cheung, IEEE Life Fellow from Hong Kong Section,
- Mr. Hareendralal, IEEE Life Senior Member from Kerala Section,
- Prof. Hyuckjae Lee, IEEE Life Member from Korea Section.

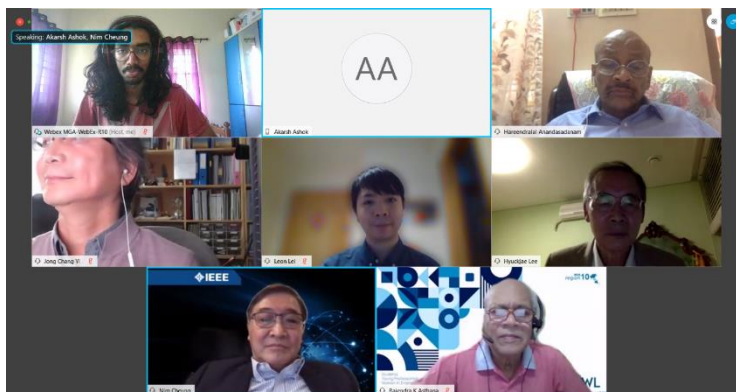

Each speaker highlighted achievements in their career and explained how they benefitted with their involvement with IEEE at various levels. 38 participants attended the session.

**LM Session 2: LMAG Meet** – The session on 28<sup>th</sup> September 2020 was inaugurated by Past R10 Director, Dr. Harbans L. Bajaj. 108 participants attended the LMAG Meet session. R10 Director, Prof. Akinori Nishihara also attended the session.



Mr. Asthana made a brief presentation on the activities of Life members at regional as well as MGA level. He also explained to the participants about the expectations from LMAGs by the Region and MGA Board. All sixteen LMAGs were invited to the meet but only 9 could attend. One common problem faced by most of the LMAGs was found to be poor

or no response from LMs due to a variety of reasons. Consensus was reached for the following items:

- To keep discussing such problems in all future meetings and try to work out a solution,
- During every future SYWL, all LMAG Chairs would meet face-to-face,
- All LMAG Chairs would meet once annually (virtually) to discuss their plan for the year. Most suitable time suggested was February,
- Countries where there are more than 1 LMAG such as Australia, India and Japan will try to meet once a year inviting all LMAGs in that country.

**LM Session 3: Life Member Activities** – Prof. Akinori Nishihara, R10 Director inaugurated the session on 29<sup>th</sup> September 2020 and Director-Elect Mr. Deepak Mathur delivered the welcome address. 107 participants attended this LM session. R10 LM Chair Mr. Asthana delivered a talk and highlighted the following:

- Detailed about LMs, LM Affinity Group, LMAG Management & Procedure, Finances and Role of Regional LM Coordinator at Region & MGA,

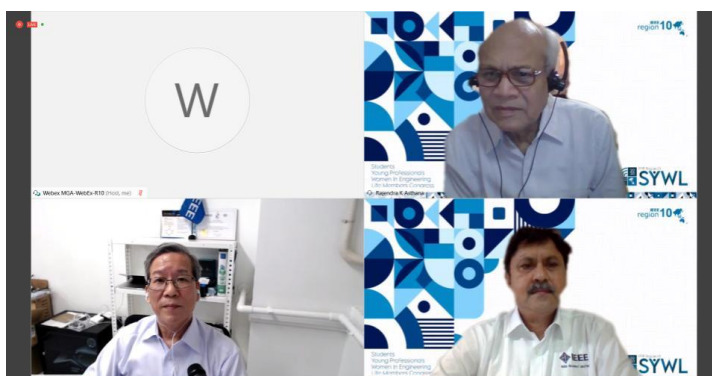

- Functions of LM Committee,
- Need of LMAGs and their importance/role,
- Financial & administrative support to LMAGs,
- Benefits for life members,
- Relationship between R10 LM Committee & LMAGs,
- Various Awards for LMs/LMAGs at Regional & MGA level etc.

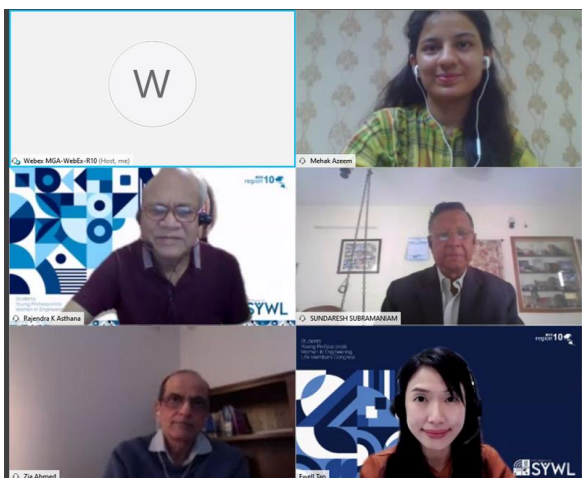

**LM Session 4: Vtools and IEEE Collabratec** – The fourth LM session was held on 1<sup>st</sup> October 2020. The session was moderated by Mr. Sundaresh Subramaniam and inaugurated by SYWL General Chair, Dr. Zia Ahmed. 343 participants attended the session.

vTools training was delivered by Ms. Ewell Tan from the Singapore Office. Ms. Mehak Azeem presented the information about the IEEE Collabratec and explained its various features and benefits. She recommended everyone to use Collabratec to keep updated about IEEE news and discussions on various topics.

**LM Session 5: IEEE Milestones** – This LM session was held on 2<sup>nd</sup> October 2020. R10 Director, Prof. Akinori Nishihara presented an overview of the session and Director-Elect Mr. Deepak Mathur delivered the inaugural address. Professor Hajime Imai from Tokyo LMAG was the invited presenter and Prof. Naohisa Ohta, Tokyo LMAG moderated the session. 89 participants attended the session. Among the main points made during the session were:

- Definition of IEEE Milestone – the achievement should be more than 25 years old. The milestone honours the achievement and NOT a person or place,
- Procedure for Milestone approval. The proposer must be current IEEE Member, who needs to obtain sponsorship from appropriate IEEE organizational unit(s) including plaque & dedication ceremony. Normally, the time taken is from 9 to 15 months,
- The proposer(s) obtains permission letter from owner of site where milestone plaque is to be placed. IEEE History Committee appoints an advocate to review the proposal,
- On approval from the History Committee, it submits the milestone proposal to IEEE Board of Directors for final approval,
- Sponsoring Organizational Unit(s) plan the dedication ceremony,
- Japan had so far dedicated 34 Milestones with another 4 under various stages of approval. Some examples are the first word processor in Japanese, Electronic television, first direct broadcast satellite service, etc.
- Tokyo Section has 20 Milestones, which is the highest among the Sections.



## Education Activities Session



The Educational Activities session in the 2020 R10 SYWL Congress invited Professor Stephen Phillips, Vice-President of IEEE Educational Activities Board (EAB) and Mr. Jamie Moesch, Manager Director of IEEE EAB. They spoke on the development and updates of EAB programs, services and products, including IEEE Learning Network (ILN), eLearning modules, English for Technical Professionals and in particular, they introduced the IEEE Ad Hoc Committee on Lifelong Learning and Continuing Education, plus the new program IEEE Academy to be launched in 2021.

The session also focused on the IEEE R10 Reaching Locals project, which aims to reach out to local community with local languages in order to:

- raise the awareness of IEEE's brand and logo,
- enhance public understanding of engineering and technology,
- provide a trusted source of educational resources and services,
- inspire a worldwide audience and expand knowledge for the benefit of humanity.

Professor Takako Hashimoto (Japan), Dr. Nia Kurnianingsih (Indonesia), Dr. Amit Kumar (India), Professor Gao Yun An (China) and Dr. Paulina Chan (Hong Kong) presented the Reaching Locals activities at their local communities and discussed the lessons and best practices from their experience. The session also had active participation from the audience with Q&A and feedback.

Aravindhnan Anbazhagan and Purva Ekatpure did an excellent job of assisting with the promotion and managing of the session. Their contributions to the event and to R10 EAC in 2019-2020 are greatly appreciated.

## IEEE Standards Association

IEEE Standard Association (IEEE SA) session led by Mr. Sri Chandrasekaran from IEEE SA and moderated by Dr. Supavadee Aramvith, took place on 29<sup>th</sup> September 2020. The theme of IEEE SA session was impact of IoT in Smart Cities. Firstly, Mr. Sri Chandrasekaran gave brief introduction to IEEE SA. There were four speakers for the session. Sandeep Agarwal from the Center for Development of Telematics gave a talk on "Mapping Public Wi-Fi Network Architecture to Smart Cities through IEEE P2872". Mr. Ashish Mahajan from IoT Sec Australia gave a talk entitled, "Understanding Security in the Medical Internet of Things". Mr. Nishant Krishna of TechMachinery Labs talked about "Bringing Cognition in the Edge using ROOF Computing - IEEE P1931". Finally, Greg Adamson, Chair IEEE DIITA Program, talked about lost of the smart cities. The session was well received with 25 participants and over 74 live viewers.

## IEEE Humanitarian Activities Session

IEEE HAC Session on COVID-19 response, the first session to happen at IEEE R10 SYWL 2020 Virtual Congress, was held on 19<sup>th</sup> September 2020. The theme of the session was HAC response to COVID-19. Dr. Supavadee Aramvith (HAC Communications Chair) and Prof. Jing Dong (R10 HTA Chair) moderated the session. The panelists included Mei Lin Fung (HAC Assessment chair), Nirupama Prakash Kumar (HAC Project Chair), Simay Akar (SIGHT Communication Chair), and project leaders from Region 10 whose projects were supported by HAC/SIGHT COVID-19 Project Funds - Allya Koesoena (Indonesia Section), Maheshi

Dissanayake (Sri Lanka Section), Suresh Merugu (Hyderabad Section), Jayakrishnan MC (Kerala Section). The session was well received with 63 participants and 680 live views.

### Closing Ceremony

The Closing ceremony for the 2020 R10 SYWL Virtual Congress was held on 4<sup>th</sup> October 2020. General Chair, Dr. Zia Ahmed; General Co-Chair, Dr. Supavadee Aramvith, and Director-Elect, Mr. Deepak Mathur addressed the participants. Prof. Elmer Dadios, Chair for Awards & Recognition announced various award winners for 2020; Ms. Emi Yano and Dr. Saaveethya Sivakumar, winners for R10 SAC & WIE Contests; Prof. Takuo Suzuki, R10 YP Contest winner and Mr. R. K. Asthana, winners for R10 Life Member Photography Contest. R10 Director, Prof. Akinori Nishihara, the gave closing remarks. The last session of the congress was the Entertainment Program, which was organized by the Entertainment Committee and hosted by Mr. Muzamil Mahmood.

The R10 SYWL Virtual Congress was supported by:

1. IEEE Entrepreneurship Committee
2. IEEE Industry Engagement Committee
3. IEEE Centre for Leadership Excellence
4. IEEE HKN Group and
5. R10 Industry Relations and Education Activities Committees





# TECHNICAL COLUMN



## 2. TECHNICAL COLUMN

### Neuromorphic System and Integrated Circuits

Byung-Gook Park, FIEEE, Seoul National University

Human brain is known to be composed of  $10^{11}$  neurons and  $10^{15}$  synapses that are capable of PFLOPs ( $10^{15}$  (peta) floating point operations per second) performance. Currently, a supercomputer that consists of  $10^5$  CPUs and  $10^{15}$  bytes of memory can also achieve PFLOPs, but consumes a few MW power, while human brain uses only 20 W. Why do the two systems with similar computing power show a whopping  $10^5$  times difference in energy used for one second?

If we ask this question to IEEE members, the expected answers would be the event-driven characteristics of neurons, massively parallel computation, the lack of bottleneck between processors and memories, etc. There is, however, an answer that can be understood by a layperson yet technically sound: it is that a digital computer based on a CPU (central processing unit) is not a hardware designed for neural network computation. A CPU is a general-purpose hardware that can process not only simple arithmetic calculations but also all sorts of instructions. It is a von Neuman machine executing sequential operations, which may experience a tremendous inefficiency in energy consumption when it is driven into the unfamiliar territory of massively parallel computing. In order to solve the problem of inefficiency, GPUs (graphics processing units) are used with CPUs in the current artificial neural network hardware. Utilizing thousands of computational cores that execute simple arithmetic calculations, the energy efficiency has been improved dozens of times in GPUs.

The fact that the improvement of energy efficiency does not scale well with the number of cores shows that there is a limit in improving the energy efficiency by blindly increasing the number of cores without a fundamental change in interconnection scheme, role distribution between memory and core, and the storage characteristic of memory. Recently, dedicated neural-network processors such as NPU (neural processing units) and TPU (tensor processing units) have raised energy efficiency significantly, but they still appear to fall behind the human brain. Especially, if we consider the capability of long-term memory in addition to that of simple arithmetic calculation, current NPUs and TPUs that use a volatile memory as their main memory cannot compete with human brain. For example, if a DRAM (dynamic random access memory) is used for synaptic weight storage, more than 1 kW will be wasted to just refresh  $10^{15}$  bytes, which correspond to the memory capacity of human brain.

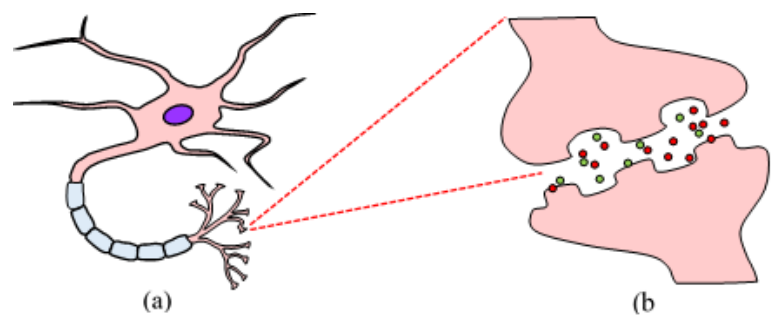
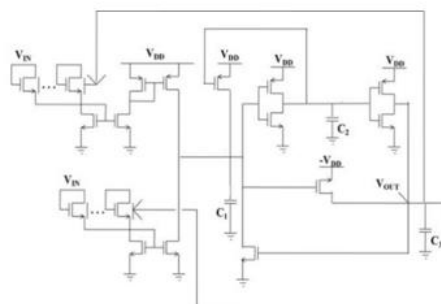
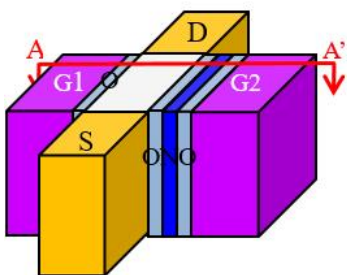

Fig. 1: Building blocks of biological neural network: (a) neuron, and (b) synapse

In order to solve these issues and implement an integrated circuit (IC) with the energy efficiency of human brain, we need in-depth understanding of biological neural networks. The first step is to take a close look at the building blocks of biological neural network: neurons and synapses. A neuron receives input signals, adds them up, and integrates them temporally. If the integrated signal exceeds a threshold, the neuron generates a spike. A synapse is located at the position where a neuron contacts another neuron, and it multiplies the input signal by a weight (computation) and transfer it to the post-synaptic neuron (interconnection). In addition to the roles of computation and interconnection, the synapse acts as a memory cell that stores the weight for a short and long term. Such an important stature of synapse is in strong contrast with the passive and subordinate role of the memory of a digital computer that is separate from the CPU (or GPU) and has only an information storage function. Interconnection is the “heart” of a neural network. It is the synapse that takes care of the interconnection strength as well as its storage. Once the synapse combines the function of memory with that of interconnection, the bottleneck between processors and memories is automatically resolved. In the biological neural network, the memory plays a key role in computation (memory-centric computing), enabling massively parallel processing.

Rosenblatt, a pioneer in the study of artificial neural network hardware, proposed the concept of perceptron by mimicking the functions of neurons and synapses in 1957 [1], and it was implemented as a hardware called Mark 1 Perceptron. The Mark 1 Perceptron was designed for image recognition and had a photocell connected to an artificial neuron. The weight of the synapse was implemented with a potentiometer, which was adjusted by an electric motor during training. Perceptrons aroused great expectations in the early days, but when it was revealed that there was no general method to train multi-layer perceptrons, they suffered from a severe downturn for a considerable period of time, eventually surviving only in the form of a software.



In the mid-1980s, when the error back-propagation technique, which can be used to train multilayer perceptron, was introduced [2], interest in artificial neural networks increased dramatically. At the same time, attempts have been made to implement artificial neural networks with VLSI CMOS ICs. However, as it became clear that it was difficult to apply the error backpropagation technique to deep neural networks of three or more layers, the artificial neural network faced a downturn once again, and expectations for the implementation of neural

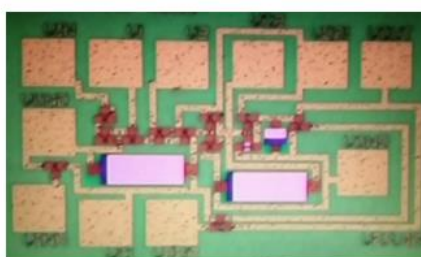
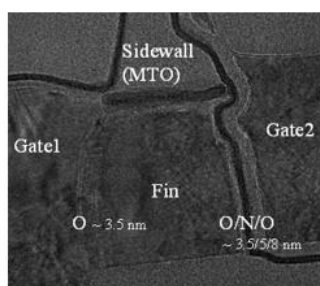

(a)

(b)

Fig. 2: Building blocks of NNIC: (a) synapse device and (b) neuron circuit

network ICs (NNICs) faded away accordingly. Research on NNICs was resumed only in the mid-2000s, when the clue to the solution of the error backpropagation problem in deep neural networks began to appear. The complete solution was found with the advent of the rectified linear unit (ReLU) in 2010 [3], and then earnest effort has been made in the area of NNICs.

In order to manufacture an NNIC with a degree of integration similar to that of a biological neural network, it is necessary to implement an artificial synapse with weight adjustability and long-term memory (non-volatile) characteristics, which are essential characteristics of biological synapses, as one device. Neurons also have to be constructed with a smallest number of devices. To achieve these goals, various synaptic devices based on flash memory [4], RRAM (resistive random access memory), PRAM (phase-change random access memory), and MRAM (magnetic random access memory) have been developed. Integrate-and-fire neurons that can increase energy efficiency through event-driven characteristics are drawing attention [5]. Fig. 2 shows the building blocks of NNIC. An artificial neural network made by combining these building blocks is called a spiking neural network (SNN), and SNN is in the spotlight as a third-generation artificial neural network most similar to a biological neural network.

The problem that SNN has not been able to solve for a while is that it is difficult to find an effective supervised learning method in deep neural networks. It was known that the learning method used in biological neural networks is spike-timing-dependent plasticity (STDP) [6], but STDP is a learning method that is performed between two layers, so that supervised learning method such as the error backpropagation technique cannot be implemented in a deep neural network. This difficulty is overcome as the equivalence between the SNN and the conventional neural network using the ReLU is discovered [7]. Two neural networks that seem to behave very differently at first glance perform the same operation if they have the same structure and synaptic weights (Fig. 3). Due to this equivalence, the same result can be obtained by transferring the weight obtained by training a software neural network having the same structure to the synapse of an SNN and using it for inference. This has opened the way for the weights obtained by using advanced software learning techniques, gained through

decades of hard work, to be implanted into highly energy-efficient hardware. The day when an NNIC rivaling human brain in energy efficiency will emerge does not appear to be far from now.

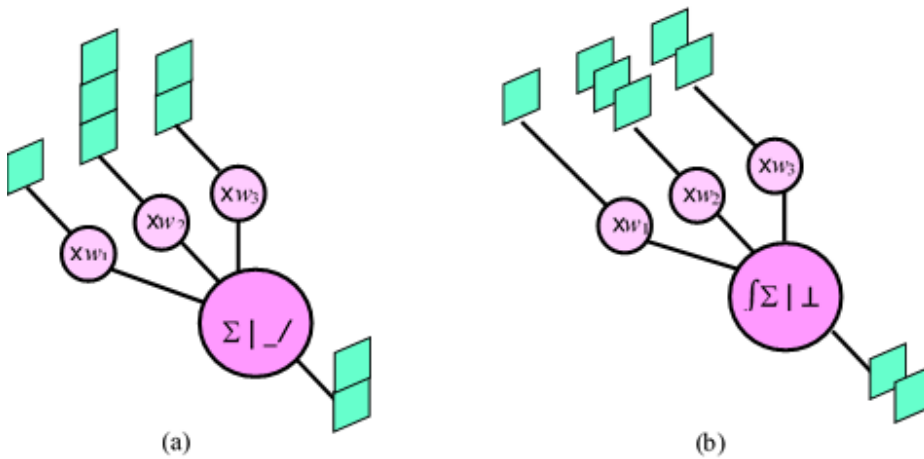

Fig. 3: Equivalence between (a) SNN and (b) neural network with ReLU activation function

## References

- [1] F. Rosenblatt, "The Perceptron - a perceiving and recognizing automaton," Report 85-460-1, Cornell Aeronautical Laboratory, 1957.
- [2] D.E. Rumelhart, G.E. Hinton, R.J. Williams, "Learning representations by back-propagating errors," Nature. 323 (6088): 533, 1986.
- [3] V. Nair and G. Hinton "Rectified linear units improve restricted Boltzmann machines," Int. Conf. Machine Learning, 2010.
- [4] H. Kim, et al., "Silicon-Based Floating-Body Synaptic Transistor With Frequency-Dependent Short- and Long-Term Memories," IEEE Electron Device Letters, 37(3), 249, 2016.
- [5] J. Park, et al., "Compact Neuromorphic System With Four-Terminal Si-Based Synaptic Devices for Spiking Neural Networks," IEEE Trans. Electron Devices, 64(5), 2438, 2017.
- [6] G.Q. Bi, M.M. Poo, "Synaptic modifications in cultured hippocampal neurons: dependence on spike timing, synaptic strength, and postsynaptic cell type," J. Neuroscience, 18, 10464, 1998.
- [7] P. O'Connor, M. Welling, "Deep Spiking Networks," arXiv :1602.08323, 2016.



Byung-Gook Park received his BS and MS degrees in Electronics Engineering from Seoul National University (SNU), and PhD degree in Electrical Engineering from Stanford University. He worked at the AT&T Bell Laboratories and Texas Instruments before he joined SNU as an Assistant Professor in the Department of Electrical and Computer Engineering, where he is currently a Professor. His research interests include the design and fabrication of neuromorphic devices and circuits, CMOS devices, flash and resistive memories. He has authored and co-authored over 1600 research papers in journals and conferences, and holds 120 Korean and 50 U.S. patents. He served as an IEEE Seoul Section Chair and is serving as an IEEE Region 10 ExCom Member. He is an IEEE Fellow, NAEK Member, and KAST Fellow.

# From Image/Video Compression to Multi-Modal Data Organization for the Future IoT Era

Seishi Takamura, FIEEE, NTT Media Intelligence Laboratories

## Image/Video compression overview

Almost every day every moment we are enjoying watching video, teleconferencing, taking/taken video/photo, posting/sending them, and looking at pictures via smartphones, TV, PC etc. More and more amount of data has been transferred over the internet. The visual data in Internet protocol (IP) traffic has been reported that IP video traffic accounted for 75% of all worldwide IP traffic in 2017 and will be 82% by 2022 [1]. Those traffic are mostly occupied by already compressed video (not raw data captured by sensors). Image/video coding, which is the same as compression, has been researched nearly a century. Its incunabulum dates back to the creation of AT&T Bell-Lab's first videophone system, called Ikonophone, in 1927 [2]. An analog television standard, NTSC, was standardized in 1941 and TV broadcasting had spread over the world.

Later, digital video representation system emerged in 1970s, whose (at the time) huge data amount naturally required compression. CCITT (current ITU-T) created the first video coding standard, H.120, in 1984, and succeeded by H.261 in 1990. In 1992, the first and still widely used image coding standard, ISO/IEC 10918 JPEG was created. ISO/IEC JTC 1/SC 29/WG 11(MPEG) created MPEG-1 (used by video CD etc.) [3], MPEG-2 (with ITU-T, widely used by DVD, HDD recorders, digital broadcasting etc.), MPEG-4, and MPEG-4 Advanced Video Coding (AVC, with ITU-T, currently the most widely used coding scheme, by Blu-ray disks, digital broadcasting etc.) in 1993, 1995, 1998 and 2003 respectively. In 2013, MPEG-H High Efficiency Video Coding (HEVC) was created, and its 3D video extensions were created in 2015. It has been used by ultra-high definition (UHD) TV, etc. Very recently, latest video coding standard, MPEG-I Versatile Video Coding (VVC) [3] was created in July 2020.

Fig. 1:  
Evolution of video coding  
technology and compression  
performance

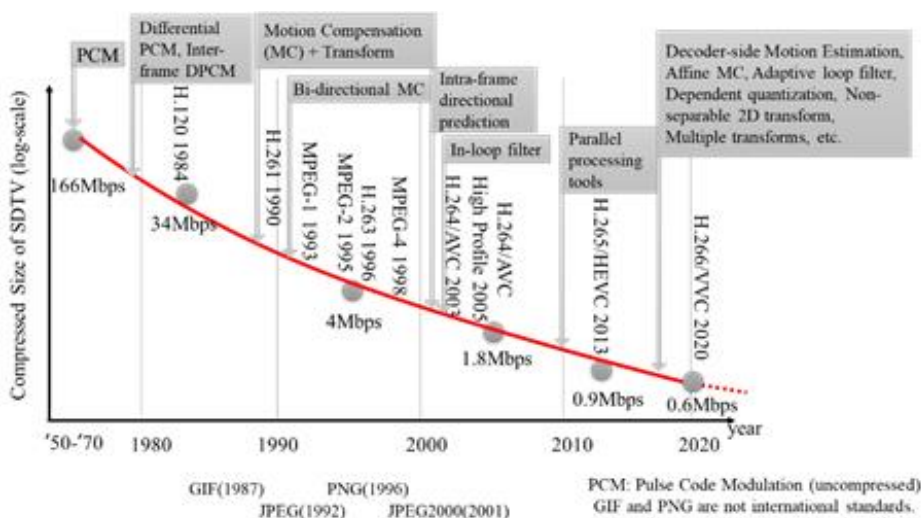

Roughly, compression performance has been doubled each time major video coding standard is established before HEVC, and steadily improving over the years (Fig. 1). VVC (with reference software VTM10.0) achieves 25% less bitrate for still image and 30-36% less bitrate for video compared to preceding standard HEVC (with reference software HM16.2). Besides its high coding efficiency, VVC is also capable of various functionalities such as screen content (non-camera-captured contents such as PC screen or gaming) coding, adaptive resolution change, spatial scalability, tile-based streaming and 360-degree video coding. Though VVC runs  $x6 \sim x24$  slower than HEVC, decoding is not very slow (less than  $x2$ ). Recently, very fast and efficient software implementation of VVC codec is developed, which provides  $x100$  faster encoding than VTM while maintaining even better subjective quality [4].

Visual image compression performance comparison between coding standards JPEG, JPEG2000 and VVC are shown in Fig. 2. They are all compressed down to 1/100 of original size. If you take a closer look, the differences

are obvious. In JPEG, both background and feather area have blocking artifacts and pseudo color distortion around bird's eye is observed. JPEG2000 still suffers from feather detail, while VVC has no obvious impairment.

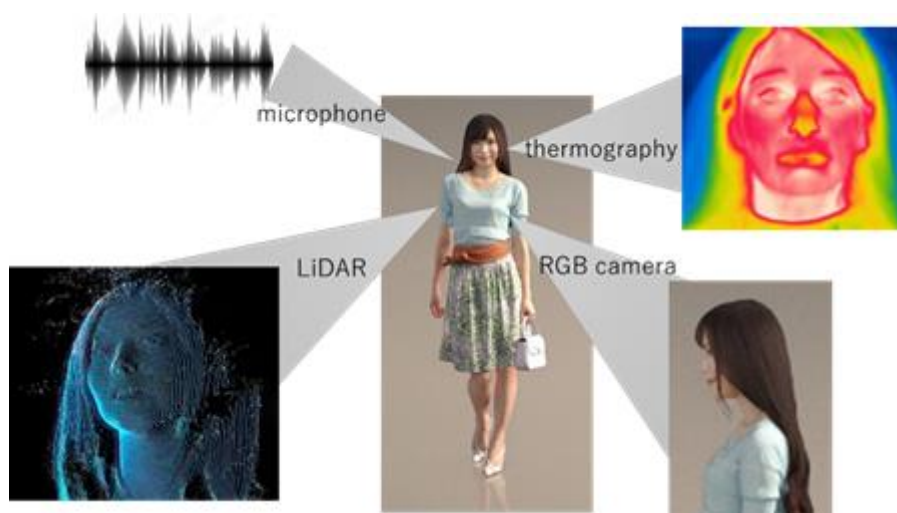

Fig. 2:  
Coded images of JPEG(left),  
JPEG2000(middle) and VVC(right)  
at the same compression rate  
(1/100)

### Organizing Increasing IoT data

Multi-modal IoT sensors (such as camera, microphone, thermometer, LiDAR, hygrometer, etc.) are expected to be deployed around the world to collect omni-ambient data, which will make various applications possible. For example, weather forecasting, disaster prevention, smart cities, surveillance, security, intelligent transport systems, infrastructure maintenance, etc. It has been reported that the growth in storage devices is expected to increase 10-fold per decade, which is estimated to reach 100 zettabytes (ZB) ( $1 \text{ ZB} = 10^{21}$  bytes) by 2030 and 1 yottabyte (YB) ( $1 \text{ YB} = 10^{24}$  bytes) by 2040. However, the growth of IoT data is expected to increase 40-fold per decade, which is estimated to reach 1 YB by 2030 and 40 YB by 2040 [5]. That literally means most of obtained data shall be abandoned without being recorded. It is easily expected that visual data occupies most of the data amount, so undoubtedly VVC will be a killer compression tool. However, since it is single-modal (i.e., only visual) oriented, still it deserves room for improvement when dealing with multi-modal data. Suppose there are two signal sources X and Y, if they have a correlation, it is always better to compress X and Y (or even more) jointly. This encourages us to leave from conventional single-modal data coding and advance toward multi-modal data coding. Fig. 3 shows an example of such multi-modal data acquisition situation.

Fig. 3: Example of correlated multi-modal data from same provenance



### Conclusion

In this article, we overviewed the long history of video coding technology and introduced the state-of-the-art performance. Then we have extended the compression target from conventional video to future omni-ambient data, and highlighted that multi-modal coding technique shall gain more importance in future IoT era. It is

expected more research efforts will be contributed to this area, and organizing such extravagant amount of data will open up new types of applications.

## References

- [1] Cisco Visual Networking Index: Forecast and Trends, 2017–2022 White Paper
- [2] M. Lauri, "Mobile Videophone", Proc. Research Seminar on Telecommunications Business, Helsinki University of Technology, pp. 37-41, Spring 2007
- [3] ISO/IEC 23090-3, "Information technology — Coded representation of immersive media — Part 3: Versatile video coding", July 2020.
- [4] A. Wieckowski et al., "Towards a Live Software Decoder Implementation for the Upcoming Versatile Video Coding (VVC) Codec," Proc. IEEE ICIP 2020, Oct. 2020
- [5] S. Takamura, "Data-coding Approaches for Organizing Omni-ambient Data," NTT Technical Review, Vol. 17, No. 12, pp. 28-34, Dec. 2019



Seishi Takamura received the B.E., M.E. and Ph.D. degrees from the University of Tokyo in 1991, 1993 and 1996, respectively. In 1996 he joined Nippon Telegraph and Telephone (NTT) Corporation, where he has been engaged in research on efficient video coding and ultra-high quality video coding. He has fulfilled various duties in the research and academic community in current and prior roles including Associate Editor of IEEE Transactions on Circuits and Systems for Video Technology, Executive Committee Member of IEEE Tokyo Section, Japan Council and Region 10 (Asia-Pacific). He has also served as Chair of ISO/IEC JTC 1/SC 29 Japan National Body, Japan Head of Delegation of ISO/IEC JTC 1/SC 29, and as an International Steering Committee Member of the Picture Coding Symposium. From 2005 to 2006, he was a Visiting Scientist at Stanford University, California, USA. He is currently a Senior Distinguished Engineer at NTT Media Intelligence Laboratories. Dr. Takamura is a Fellow of IEEE and IEICE, a senior member of IPSJ, and a member of MENSA, APSIPA, SID and ITE.



# R10 PERSONALITIES OF THE MONTH





### 3. R10 PERSONALITIES OF THE MONTH

#### R10 Personality of the Month – Atul Negi

##### Hyderabad Section

Atul Negi first joined as an IEEE Student Member in 1993 and completed 28 years as an IEEE Member. He has been actively contributing as an IEEE volunteer since 1998. His first volunteering assignment was as the Student Branch Counselor of IEEE Student Branch, University of Hyderabad. He was elected to the executive committee of the IEEE Hyderabad Section and served as the Students Activities Chair during 1999-2000. After serving in the executive committee, he was elected as the Computer Society Chapter Chair during 2004-2005. After serving as Section Treasurer and Section Vice-Chair during the years 2006-2007, he was elected Section Chair for IEEE Hyderabad Section during 2012-2013.

During this period, he was part of two major events for Region 10 in Hyderabad, the first being the Region 10 WIE Congress (WIECON2012) in March 2012 which attracted 607 participants from many states of India, Sri Lanka and Bangladesh. In July 2013, Hyderabad Section hosted the Region 10 Congress of WIE, Students and GOLD (Young Professionals used to be known as Graduates of the Last Decade) in a grand manner. Dr. Negi was also part of the initiation of the following Chapters in IEEE Hyderabad Section: Computational Intelligence Society Chapter, CAS/EDS Joint Chapter, Photonics Society Chapter, and Education Society Chapter. As Section Chair, he helped initiate the Conference Organizers Workshop series for IEEE Conference organizers.

Registration at WIECON2012



Region 10 Meeting 2013 Receiving Large Section Award, Hyderabad Section from Toshio Fukuda then Director Region 10.



Dr. Negi was a member of the organizing committee and publications co-Chair for TENCON2008, when it was hosted by IEEE Hyderabad Section under the leadership of Prof. Arun Agarwal at University of Hyderabad. He was also active as the track co-chair for Computational Intelligence track in TENCON2019 in Kochi, hosted by Kerala Section. For TENSYP 2015 organized by Gujarat Section, he was Tutorials Chair and he helped as track chair during TENSYP2017 organized by Kerala Section.

Dr. Negi was active in IEEE India Council and was the publications chair and Computing Track co-chair for INDICON2011. During INDICON2019, he was Tutorials Chairs as well as the invited speaker. He was the Vice-Chair of Educational activities for India Council during 2017-2018. He has attended Sections Congress in Sydney in 2017 and was part of the CAS Chapter team giving lectures at IoT Workshop at Bandung Indonesia Section CAS Chapter. For his efforts as an IEEE volunteer, he was awarded the 2020 R10 Outstanding Volunteer Award.

Dr. Atul Negi is currently working as a full professor in the School of Computer and Information Sciences at University of Hyderabad, Telangana, India and previously worked as Director at PIES, Indore, India. He holds the Ph.D. and MSc (Engg.) degrees from University of Hyderabad and Indian Institute of Science (IISc), Bangalore, India, respectively. He graduated with distinction in Electronics and Communication Engineering from Osmania University, Hyderabad, India in 1986. He has delivered the IETE Distinguished K. K. Nair memorial lecture in 2012 and was a keynote and inaugural speaker at several national conferences in India. His work on pattern recognition and document imaging is well cited and he has more than 100 publications in peer-reviewed conferences and journals.

With R10 Director-Elect Prof. Lance Fung at Mini-POCO in Hyderabad



# R10 WIE Personality of the Month – Qiaowei YUAN

## Sendai Section



Qiaowei YUAN (<https://researchmap.jp/qiaowei?lang=en>) received her BE, ME, and PhD from Xidian University, Xi'an, China, in 1986, 1989, and 1997, respectively. From 1990 to 1991, she was a special research student at Tohoku University, Sendai, Japan. From 1992 to 1995, she worked at Sendai Research and Development Laboratory, Matsushita Communication Company, Ltd. (Panasonic System Networks R&D Lab. Co., Ltd.), engaging in researching and designing of compact antennas for second generation mobile phones. From 1997 to 2002, with Sendai Research and Development Center, Oi Electric Company, Ltd., she was involved in researching and designing of small antennas for pager communications and the parabolic antenna for 26.5 GHz fixed wireless access (FWA) communication. From 2002 to 2007, with Intelligent Cosmos Research Institute, Sendai, Japan, she was involved in the research and development of adaptive array antennas and RF circuits for mobile communications. From 2007 to 2008, she was an Associate Professor at Tokyo University of Agriculture and Technology. From 2009 to 2019, she served as the Associate Professor/Professor at National Institute of Technology, Sendai College. Currently, she is the Professor and the head of IoT technology research project in Tohoku Institute of Technology. She was also a visiting scholar at ElectroScience Laboratory of Ohio State University in USA from April 2015 to September 2015.

Although Dr. Yuan has switched her career from industry to academic, her major has never changed, focusing on electromagnetic wave engineering. Dr. Yuan received the Best Paper Award and Zenichi Kiyasu Award in 2009, from the Institute of Electronics, Information and Communication Engineers (IEICE) of Japan. She has also received the Achievement Award from IEICE in 2015, and other Achievement Awards from IEICE Technical Committee on Wireless Power Transfer from 2016 to 2017, and IEICE Technical Committee on Antenna Propagation in 2020, respectively.

Dr. Yuan is an IEEE Senior Member belonging to IEEE Sendai Section, Japan. Currently, she is the Chair of Sendai Women in Engineering (WIE) Affinity Group, the executive committee member of IEEE Sendai Section, WIE committee member of IEEEEMTT Society, IEEE MTT-25 wireless power transfer and energy conversion committee member (<https://mtt.org/profile/qiaowei-yuan/>).



In April 2017, together with previous Sendai WIE Chair Dr. Basabi Chakraborty and Treasurer Mr. Hitoshi Kikuchi, Dr. Yuan dedicated herself to establish Sendai WIE and served as the first Vice-Chair of Sendai WIE during 2017 to 2018. From 2019, as the Chair of Sendai WIE, Dr. Yuan has been working on increasing the number of Sendai WIE members, organizing high quality events involving more and more young females to enjoy science and technologies, and connecting with other domestic/international WIE groups. As a result, the number of Sendai WIE members has increased to 19 from 6 at the establishment and several annular activities have been successfully organized. Sendai WIE has already submitted five R10 Newsletters for reporting its activities since its establishment. Sendai WIE will continue its journey to move forward actively with more and more members in the Tohoku area of Japan to continuously support women in engineering (<https://www.ieee-jp.org/section/sendai/AG/wie/index.html>).

Dr. Yuan feels that she has benefited and been inspired by other fabulous WIE leaders and WIEs, widening her humanity network by attending and prompting various IEEE volunteer activities. Dr. Yuan will be R10 committee member from 2021 and is looking forward to promoting and participating many more R10 WIEs activities.

# R10 YP Personality of the Month – Aravindhan Anbazhagan

## Madras Section

Aravindhan Anbazhagan is an engineer, educator, soft skill trainer and an aspiring entrepreneur. Professionally, he graduated with his undergraduate degree in Computer Science Engineering from Sri Muthukumaran Institute of Technology, Chennai in 2016. Because of his interest and passion in education and social sector, he served as a full-time teacher at Chennai Middle School, MGR Nagar as part of the Teach For India Fellowship Program from 2016 to 2018. He also served as a member of the staff team of Teach for India - Chennai from 2018 to 2020. He recently founded a virtual education startup, EduRiseGlobal ([www.eduriseglobal.com](http://www.eduriseglobal.com)) with a vision to provide quality online education for everyone.



*IEEE Membership at MES College of Engineering, Kerala*

His journey with IEEE started seven years ago in 2013, when he was inspired by his seniors to join the world's largest technical and professional organization. He actively took up the leadership responsibilities and involved in organizing more than 30 activities with the support of his Student Branch & CS Chapter team, including the White Talks initiative, SPAC 2015. He was also actively involved with the activities of IEEE Madras Section as a student ambassador of IEEEExtreme, IEEE Day and IEEEmadC. This was also the time he developed his leadership, content writing, and public speaking skills, which according to him were very helpful as he approached his professional life.

After his graduation, Aravindhan continued contributing to IEEE and served on diverse committees, including IEEE CS India Student Activities Committee (Chair 2017-2018), IEEE Madras Young Professionals Committee (Member 2017-2019; Chair 2020), and IEEE Region 10 Educational Activities Committee (Member 2018-2020). He initiated the IEEE Young Professionals Committee of IEEE Professional Communications Society and served as the YP Representative during 2019-2020. He also actively contributed to the growth of educational activities in India and is currently leading the IEEE Inspire India team, a project funded by NIC.

Over the past 7 years, he has involved himself with more than 150 student and young professional activities and delivered guest lectures and membership development talks at over 75 institutions. He enjoys interacting with the students and shares his experiences. Aravindhan represented IEEE Madras Section at the flagship events including, IEEE R10 SYWL (2015, 2016 & 2020) and IEEE Sections Congress (2017). He led the Program Committee of All India IEEE Computer Society Students & Young Professionals Congress 2018 held at Goa, which had a participation of over 150 delegates. During the lockdown, he has spoken at more than 40 webinars organized by various IEEE OU's around the globe and initiated the ProSpeakers Mentoring Program with the IEEE ProComm Young Professionals team, through which 8 first-time speakers received the opportunity to get mentored, and to speak at a forum for the first time.



*IEEE MGA Young Professionals Achievement Award 2019*

Aravindhan has won many laurels as an IEEE volunteer including, IEEE CS Richard E Merwin Scholarship (2014), IEEE MGA Larry K Wilson Achievement Award (2016), IEEE EAB Meritorious Achievement Award in Pre-University Education (2018), IEEE CS Continuous Service Award (2019) and IEEE MGA Young Professionals Achievement Award (2019). According to Aravindhan, one of the key motivation factors with IEEE, is the opportunity to network and work with other incredible volunteers around the globe, through which he has learnt a lot of new things and acquired new skills. He believes in the quote, 'You don't need to be someone to do something for others; you have to do something for others to become that someone.'



*Speaking at TEDx event held at GCEK, Pune during 2019*

# R10 Student Personality of the Month – Indhumathi Gunasekaran

## Madras Section



Ms. Indhumathi Gunasekaran is an Associate Software Engineer at Accenture, India. She completed her Bachelor in Engineering in Electronics and Communication Engineering from Panimalar Institute of Technology (PIT), Chennai, India. She is currently serving in the roles of Regional Student ambassador of Region 10, Publicity and Promotions Lead of IEEE WIE International Leadership Summit 2020, Member of PELS Students Sub-committee, Member of PELS Women in Engineering, Founding Chair of Nuclear and Plasma Sciences Society and IEEE Brand Ambassador. She has served as the Section lead of IEEEExtreme 14.0, Student Chapter Ambassador of Power and Energy Society, Chairperson of Computer Society Chapter of IEEE Panimalar Institute of Technology Student Branch & Vice-Chairperson of IEEE PIT SB. Indhumathi was previously the IEEE Student Branch Secretary and Chairperson of Women in Engineering AG of the Student Branch.

Indhu has won the IEEE Women in Engineering Inspiring Student Member Award in 2020 for her distinguished leadership and outstanding contributions as a volunteer, at the Section and Regional levels, serving the IEEE and IEEE Women in Engineering for the benefit of its members and the engineering profession; IEEE CS Richard E Merwin Scholarship for her outstanding leadership as a Student Volunteer; IEEE CS Upsilon Pi Epsilon Scholarship and Grace Hopper Celebration India Scholarship in recognition of her outstanding academic and professional accomplishments.

Acknowledging her achievements, she has been awarded the "Outstanding Student Award 2020", "Emerging Student Volunteer" award for the year 2018 and "The Best Student of the Year 2018" by Indian Society for Technical Education (ISTE) Tamil Nadu Section level in their 18<sup>th</sup> Annual Convention. She has also proved herself in academics with outstanding performance. She secured the first rank in her department during the university examinations for several academic years. She has been an active participant, volunteer and has coordinated and organized many co-curricular and extracurricular activities. She has been and will always be a source of inspiration for upcoming minds in her alma mater. In her spare time, she founded and served as organizing secretary for She-the coder and initiated several school education programs. Her kindness, determination and courage have resulted not only in several achievements but also blossomed her into a remarkable person.

Indhumathi Gunasekaran speaks of her experience with IEEE, *"My IEEE journey has been a journey full of learning and discovery. When I first stepped into IEEE, I was not completely aware that IEEE would take me here to the one who I am today. During my initial days, I wasn't aware of the opportunities underlying for a Student Member in IEEE. But then I found ways to explore more by taking part in various programs right from my SB events to lots of global events. Attending conferences and volunteering for a greater cause expanded my network globally, resulting in gaining valuable connections of multiple eminent personalities from industries & academia.*

*I have started my journey as a delegate and gradually grown to be a volunteer in coordinating & organizing several international events. All through the various phases of this journey, IEEE has taught me numerous things—including dealing with uncertainties, being open-minded, developing social responsibility, cultural awareness, balancing personal and professional life, building self-esteem and giving back selflessly. Through IEEE, I was able to give back to the community by helping others in whatsoever way I can (by mentoring other students, taking part in STAR Program, reaching out to the children in need, taking initiatives in organizing technical programs, etc.). In fact, I found time to spread smiles. Every skill learned, mattered!*

*I could say that the important component required for the growth of any Engineers would be the knowledge of ground-breaking technologies, mentoring and networking. And IEEE gives you the best combination of all these three. The free access to IEEE publications helped me in staying current with the technology. Having the right mentors by my side helped me in achieving greatness not just in terms of work, but also in terms of life in its*

overall fundamentality. A special thanks to my mentor Mr. Arun M. (SBC | Assistant Professor, ECE | Panimalar Institute of Technology) for the mentorship that he has given me over the past years. Having the opportunity to learn from him has made a substantial change in my life. I never imagined I would be able to make as much progress as I have. Thanks to Mr. Arun M., for teaching me so much. I'm always grateful to him for his support and kindness.

Finally, it isn't super easy for anyone to keep up the life curve growing. Many of us quit at times when we are faced with rejections or failures. Learning from failures and progressing hard requires lots of courage. The spirit that I gained from my co-volunteers and my mentors kept me going all through these years having this wonderful experience to share with you all!"

## R10 Life Member Personality of the Month – A. G. Hareendralal

### Kerala Section

A.G. Hareendralal is a Life Senior Member of IEEE. His association with IEEE can be divided into three phases, namely learning phase in Kerala Section from 1982 to 1993; mentoring phase in UAE Section of R8 from 2000 to 2008; and golden phase, again with Kerala Section from 2012, winning several laurels. Though he came across IEEE as a student from IEEE Periodicals, he could not realize his dream of IEEE membership due to the subscription cost and lack of adequate information about its benefits. But the constant encouragement by his colleagues paved the way for his obtaining a membership in IEEE in 1982 and continued to be a member in spite of financial problems.

His first challenge was organizing National Workshop on 'Computer Application in Power System' in 1985, which was a grand success. This workshop provided him lot of opportunities: networking throughout the country, and achieving success in implementing computer applications in the power utility by procuring the first computer systems. This positive step led to a series of innovations in his company. This includes the installation of the first



Wind Electric Generator, non-invasive detection of failures in underground cables, and attempting cloud seeding for the first time by a power utility in the country. This was a milestone in his career and aided him in his profession to a great extent.

Soon, he served Kerala Section in several capacities and finally becoming the Chair of Kerala Section in 1992. During this period, Kerala Section reached a commendable position in India Council as well as Region 10. He gratefully reminisces those periods where he worked guided, mentored and supported by the stalwarts of Kerala Section.

He joined the UAE Section as its Secretary in 2000. It was almost dormant with limited activities, around 200 members and one Student Branch. When he left UAE in 2008, the Section has more than 3000 members, with 6 Chapters, 11 Student Branches, one Sub-section and several International conferences to its credit. He was the founder Chair of PES UAE Chapter from 2000 to 2005. During this period, he could get recognition from several quarters because of his association with IEEE.





He was the Chair of PES Kerala Chapter and Vice-Chair in Charge of LMAG Kerala Section during 2016-2017 and Chair of LMAG for 2018-2019. During his chairmanship, PES Chapter saw phenomenal growth in its Membership and became the largest PES Chapter of IEEE and the Chapter won the Outstanding Small Chapter Award for 2017. LMAG was also adjudged the Outstanding LMAG for 2017.

During this period, more than 250 programs under PES and LMAG were organised on different topics for different target groups in line with the tag line of IEEE, “Advancing Technology for Humanity”. These include programs for housewives towards “Women Empowerment”, for socially and economically disadvantaged communities to uplift their social and economic status, and also for pre-university Students, first year Engineering Students, Student Members, Young Professionals, Women in Engineering, etc. These were organised joining hands with different organisations and different IEEE entities (YPs, WIEs, LMAGs, different government departments, different NGOs). Variety was the hallmark of the PES Chapter during this period.

He was adjudged the India Council Outstanding Volunteer Award in 2018, and R10 Outstanding Life Member Volunteer Award in 2020. Currently, as the Chair of Intersociety Activities Committee, he is working with 6 other professional organisations. The committee is successfully organising a Weekly Webinar Series every Wednesday between 6pm and 7pm IST. The Webinars have been received well by the participants from 15 countries making it a grand success.

Hareendralal feels that his association with IEEE has imbued a sense of professionalism in him and credits this to his success in his career and profession. IEEE is a platform where persons with different profiles can perform well in improving the quality of life for themselves as well as the society.

## R10 COVID19 Personalities of the Month – C Subramaniam, Syuhaida Ismail and Wan Nurul Mardiah Wan Mohd Rani

Universiti Teknologi Malaysia Kuala Lumpur (UTMKL)

### ***Communication Effectiveness at Construction Site during COVID-19 Outbreak in Malaysia: Case Studies of G7 Contractors***

The construction industry is severely impacted due to the COVID-19 outbreak. As a labor-intensive industry clocking 7.2 percent annual growth rate, the construction industry is hugely impacted with currently a 60% decline in the annual turnover due to the COVID-19 pandemic. The Movement Control Order (MCO) due to the



*Briefing and site visit by main contractor at Site-PJS*

COVID-19 pandemic has currently stalled all activities at the construction sites. The construction industry is facing a bleak future; delays at construction sites are a certainty and would subsequently result in cost escalation. Many companies are unable to cope with such losses. Apart from this, many construction workers are also in despair as they have lost their jobs. Taking note of this inimical impact on the construction industry, the Government of Malaysia has cautiously decided to loosen the restrictions under the MCO and slowly permit various activities to

resume at the construction sites. The stakeholders majorly affected by this intervention are apparently the construction employees, who are largely involved in the day-to-day construction activities at sites, as well as other construction industry stakeholders such as the contractors and sub-contractors, consultants, developers, clients suppliers and those involved in the construction industry supply chain. Hence, effective Communications Management (CM) is crucial in construction projects as it is very complex and involves various stakeholders, especially with MCO restrictions, wherein physical meetings and discussions are limited.

Use of online work environments could be the panacea for the construction industry, but even these solutions require effective CM. The construction industry does not have the luxury of working from home, because there is a substantial need for physical presence. Therefore, this study aims to investigate the communication effectiveness at the construction site during the COVID-19 outbreak based on the CM practice in Malaysia. This investigation involves 3 case studies involving G7 contractor companies currently working on mixed development projects in Malaysia. A series of interviews were conducted with the top management at the construction site to examine each company's current CM practice. In addition to this, a questionnaire survey was also distributed to the general workers to assess communication effectiveness during the COVID-19 outbreak. The findings were that two of these contractor companies demonstrated high communication effectiveness due to the implementation of the Internet of Things (IoT), morning briefing, single lingual use and friendly communication approaches. However, the other contractor displayed poor communication effectiveness due to lack of IoT implementation, multilingual practice and inferior communication approach at the construction site. This study concluded that CM practice directly affects communication effectiveness at the construction site. The use of single lingual practice, IoT implementation as well as barcode scanning for latest instruction and report updates keep site workers updated. Friendly communication approach at the construction site also helps the general workers understand better to increase communication effectiveness.



*IEEE students volunteers performing data collection with site supervisors*



*IEEE students volunteers performing data collection at Centralised Labour Quarter (CLQ)*

Check out the multimedia version of the COVID-19 Personality of the Month at the link below:

<http://newsletter.ieeer10.org/home/covid-19-videos/>



# R10 ORGANIZATIONAL UNITS (OU) OF THE MONTH





## 4. R10 ORGANIZATIONAL UNITS OF THE MONTH

### R10 Large Section of the Month – Hong Kong Section

Prepared by: Paulina Chan, Chair for HK Section & Leon Lei, Newsletter Editor for HK Section



with 20 Chapters, 3 Affinity Groups, and 5 Student Branches.

The Section has vibrant chapters, student branches, and affinity groups. Recently, the section received support from IEEE Region 10 Membership Development and Leadership Training Fund for further enhancing and improving membership recruitment, retention, and reinstatement (the "3Rs") of the Section. The Section also launched the "IEEE Gift of Membership Program" to offer complementary memberships to motivate new entrants of Student Members to all five Student Branches. The Section and Young Professionals Affinity Group (YPAG) organized a Tech-in-Life (TIL) Business Hackathon for teams of students from universities. Unlike traditional hackathons, this TIL hackathon focused on business planning and product development rather than programming a prototype. The goal was to encourage everyone to think out-of-the-box and solve problems through effective teamwork. All team members gained insights beyond their classroom experience towards benefits in career planning, personal development and networking.

The Section has been recently declared the Winner for the IEEE Region 10 Educational Activities New Innovative Challenge (Pre-University Category) for its initiative "Empower Diversified Learners in Hong Kong with IEEE TryEngineering". The section is now actively designing a series of blended activities for local secondary school students based on the adaption of IEEE TryEngineering resources and VR resources. The first theme will be on "Fighting against COVID-19". Meanwhile, the Education Chapter worked closely with e-learning support teams in universities for helping teachers to overcome challenges in conducting their remote/hyflex teaching during COVID-19. This initiative has also been shortlisted for the E-Learning Award in the Wharton-QS Reimagine Education Awards 2020.

The Section has also closely collaborated with industries and Region 10 committees on professional activities. For example, there is an active collaboration with external partners on Continuing Education on Deep Learning workshop. Section members also attended and presented in tracks of Region 10 SYWL Biannual Congress on sharing experiences with other Sections.

Some of the recent achievements of the HK Section include:

- Region 10 Best Membership Growth (Large Section) Award
- Region 10 Best Membership Retention (Large Section) Award
- Region 10 Student Membership Development and Leadership Training Fund: Recipient
- Region 10 Educational Activities New Innovative Challenge (Pre-University Category): Winner
- Region 10 Individual Benefits & Services (IBS): Rank 1 Best Proposal Award

The COVID-19 pandemic has generated pendulum changes in organizational ecosystems and made all embrace new norms. For the Hong Kong (HK) Section, it was a big challenge but also a huge opportunity to fulfill our goals of providing individual benefits and services to current and prospective members. The Section was inaugurated in 1972. As of November 2020, the section has 9,570 members,



**2020 Outstanding Section Membership Recruitment and Retention Performance**

**Hong Kong Section**

## R10 Medium Section of the Month – Tainan Section

Prepared by: Jiann-Fuh Chen, Chair for Tainan Section



The IEEE Tainan Section, located in southern Taiwan, was initiated by a preparatory committee and formally established in 2003. It provides services to the members who reside in Yunlin, Chiayi, Tainan, Kaohsiung and Pingtung. It has grown to a medium Section with currently more than 700 members and 18 Chapters along with two Student Branches. The Section is named after the city of Tainan, an ancient capital city on the island of Taiwan. For its rich folk culture and countless historical monuments, Tainan has become one of the most popular sites to host international conferences in Taiwan.

The mission of the Tainan Section includes:

- 1) Basic assistance to members of Tainan Section in membership development,
- 2) Dissemination of knowledge in the broader fields of electrical and electronics engineering through holding of technical talks, seminars, conferences, symposia, workshops, tutorials, etc.
- 3) Assistance to IEEE members in developing chapters and organizing various activities,
- 4) Support to Student Branches.

Among its promotional strategies to recognize the technical achievements of members in industrial applications, the Section has instituted awards such as IEEE Tainan Section Delta Award, IEEE Tainan Section Macronix Award, and IEEE Tainan Section Himax Award. These awards have been highly appreciated by the members.

2020 was a rough year for the Section due to the pandemic. Many sponsored conferences were either cancelled or held virtually. Nonetheless, the Section has been holding all the regular board meetings and annual member meetings with adequate safety measures. The constant activities, though not in a large scale, allowed the Section to bring its members together during these difficult times. Looking ahead, the Section will continue to stay alert and cooperate with R10 to promote various activities considering the restrictions.

Thanks to the contributions of the Section officers over the years, the Tainan Section continues to thrive both in academics and industry relations. For its efforts, the Section was awarded the R10 Best Membership Growth Medium Section Award in 2020.

# R10 Small Section of the Month – Australian Capital Territory (ACT) Section

**Prepared by: Fouad Karouta, Chair for ACT Section**

The ACT Section (<http://ieeect.org/>) was established in 1988 with its membership being around 500. This membership base is essentially due to a high membership among employees of Government agencies located in Canberra.

In 2019 the ACT Section held 5 administrative meetings and all the Chapters and Groups maintained the status of “Active” with a minimum of two reported technical activities. The total technical activities of the Section totalled 34. Here, we need to highlight the extraordinary effort of one Chapter: the SMC Chapter chaired by Dr. Daoyi Dong, who organised and reported an impressive 14 technical activities (seminars), likely an all-time record in the Section or at least in the last 11 years.

The Section is very proud of receiving the R10 award of “Best Small Section” in 2019. This is an excellent stimulus for our volunteers to keep up with the good work.

This year was a particular year in Australia with drought and bush fires severely hitting the country (December 2019 to February 2020), in particular the New South Wales and Australian Capital Territory regions, with bush fires menacing Canberra around the Christmas/New Year period rendering the atmosphere unbreathable and forcing the population to use masks for protection. In January 2020 Canberra was hit by a severe hail storm causing numerous damages in properties and cars (thousands of cars). Then came the COVID-19 pandemic disrupting all socio-economical activities in the country (and the world) forcing all events and meetings to be carried out online from April 2020 onwards.

With restrictions easing in the last quarter of 2020, the ANU Student Branch organised a hiking tour to the summit of the Black Mountain for ANU students on 1<sup>st</sup> November 2020. Hiking started after a walkthrough of Australian National Botanic Gardens, followed by visiting the Telstra tower that offers an impressive view of Canberra (see Picture 1). Aside from this physical activity, the goal of this event was to give IEEE students the opportunity to get to know each other and thereby strengthen the IEEE community.

Similarly, the AGM was held as a live meeting on 26<sup>th</sup> November 2020 with over 40 members attending the event, some with their partners and children. At the AGM, the ExCom 2021 was elected. Picture 2 (top) depicts a part of the AGM gathering, and (bottom) shows the outgoing Section Chair Fouad Karouta with the incoming Section Chair Ambarsih Natu (seated).



*Picture 1- Lake Burley Griffin and Canberra CBD from the Telstra Tower*



*Picture 2- Part of the gathering at the Black Mountain Peninsula (top) and transfer of power between outgoing and incoming Section Chair.*

# R10 Student Branch of the Month – UCET Islamia University of Bahawalpur

Prepared by: Sameea Abbasi & Farasat Ali, IEEE UCET-IUB Student Branch

## Branch Introduction

The IEEE UCET – Islamia University of Bahawalpur (IUB) Student Branch, established in April 2010, has six technical chapters and one affinity group working enthusiastically for the past 10 years. The affinity group WIE was formed in 2013 under IEEE UCET-IUB and is dedicated to promoting women engineers, scientists, and inspiring girls in the South Punjab region of Pakistan. The technical chapters of IEEE UCET-IUB include IEEE PES, IEEE ComSoc, IEEE IAS, IEEE SMCS, IEEE SPS, and IEEE EMBS student chapters. The IEEE UCET-IUB is one of the most active branches of Pakistan and Region 10. It has won IEEE R10 SAC Best Student Branch Award twice and recently achieved a historic feat of winning awards in all 8 categories at IEEE Lahore Section AGM 2019. For the last two years, the branch has been able to achieve a membership count of more than 50 and a retention rate of 60-70% through various incentives offered to its volunteers. The IEEE UCET-IUB and its technical chapters organized more than 60 events including 3 mega-events in the last two years and won grants from IEEE Foundation and a special IEEE HAC grant for the COVID-19 project. The branch aims to achieve more in the coming years and continue to grow with time - <https://www.facebook.com/IEEE.UCET.IUB.SB>.

## IEEE UCET-IUB Mega Events

### 3<sup>rd</sup> IEEE Bahawalpur Subsection Student/YP/WIE Congress 2019 (2-day event, 500+ participants)

The IEEE Bahawalpur Subsection Congress was hosted by the IEEE UCET-IUB student branch in 2019. The two-day event was attended by students and professionals from more than ten engineering and computer science institutes in Southern Punjab. The main agenda of the event was to provide a platform for students to meet researchers, entrepreneurs, young professionals, women engineers, and fellow students to discuss the advancements in their respective fields - <https://www.facebook.com/bssywc>.



### 4<sup>th</sup> IEEE Asia/Pacific ComSoc Summer School Program 2019 (4-day event, 150 participants)

The 4<sup>th</sup> Asia/Pacific IEEE ComSoc Summer School 2019 was organized by IEEE UCET-IUB SB in collaboration with the IEEE ComSoc Lahore Chapter, IEEE Bahawalpur Subsection, and KICS-UET Lahore at the Islamia University of Bahawalpur from 9<sup>th</sup> to 12<sup>th</sup> October 2019. The theme of the summer school was 'Autonomous Systems'. Renowned professors, researchers, and academicians participated as distinguished speakers - <https://www.facebook.com/IEEE-ComSoc-Summer-School-2019-100507591299359>.



### IEEE Foundation, Awareness on Production of Sustainable Energy through Bio-Gas Project

The IEEE Foundation approved a grant of USD10,000 for the project "Awareness, Producing of Sustainable Electricity Bio-Gas". This project focused on promoting clean and green energy using animal waste. The UCET-IUB student branch is the first student branch in Pakistan to secure a grant from the IEEE Foundation. In addition to a fully functional Bio-Gas plant, the IEEE UCET-IUB organized a series of awareness activities including seminars, panel discussions and competitions. A national-level virtual seminar and a poster competition were organized recently wherein highly qualified panellists joined the discussion and gave their suggestions regarding the production of energy through Bio-Gas in Pakistan - <https://fb.watch/2cCA6PCB8W>.

## IEEE UCET-IUB Flagship Events - IEEE AEPEX

The Annual Engineering Project Exhibition is a flagship event of the IEEE UCET-IUB Student Branch, which is being organized annually for the past 10 years. The main objective of AEPEX is to provide a platform to the graduating batches where they can exhibit their senior design projects for students, professionals, industry representatives, etc. A large number of attendees visit this exhibition every year wherein more than 50 senior design projects are displayed - <https://www.facebook.com/media/set/?vanity=IEEE.UCET.IUB.SB&set=a.2343500412385481>.

## Other Events Organized by IEEE UCET-IUB in 2020

1. 3<sup>rd</sup> Episode of IEEE SPAA Week 2020
2. IEEE Foundation Project “Awareness and Production of Sustainable Electricity through Bio Gas”
3. IEEE YP Local Activity, I Have Degree, Now What?
4. IEEE Orientation 2020
5. IEEE HAC Seminar on Utilization of Robotics and Drones against Locust Attacks
6. IEEE HAC Special Grant for “Automated Hospital Assistance System for Isolated Patients of COVID-19”

The IEEE UCET-IUB SB conducted a series of online and hybrid events during the year 2020. The events were designed keeping in view the problems faced due to the pandemic. Moreover, the events were an effort to continue the activities of the Student Branch and try to engage a diverse audience through an online platform. We used this opportunity to conduct a membership campaign through our events as well.

## IEEE UCET-IUB Local Activity during COVID-19 Pandemic – Hand Sanitizer Project

The IEEE UCET-IUB SB in collaboration with the IUB Science Society prepared hand sanitizers in the university lab. These hand sanitizers were distributed among the staff members and the local community of IUB including the security guards and sweepers free of cost. Moreover, they were also handed over to the local hospitals and police stations for the on-duty staff -



<https://www.facebook.com/112791492123062/posts/2878765362192314/>

## IEEE Funded Projects (2020):

- IEEE Foundation Grant of USD10,000 for “Awareness and Production of Sustainable Electricity through Bio Gas”
- IEEE HAC Special COVID-19 Project Grant of USD9600 for “Automated Hospital Assistance System for Isolated Patients of COVID-19”



## IEEE UCET-IUB Awards (2019-2020)

1. 2019 IEEE Lahore Section AGM
  - i) Best Student Branch, ii) Best WIE Chapter, iii) Best Branch Counsellor 'Dr.Asjad Amin', iv) Best Student Volunteer 'Maria Ali', v) Best YP Volunteer 'Usman Zafar', vi) Best Student Technical Chapter (IAS) (Runner-Up), vii) Best WIE Professional 'Anum Farooq' (2<sup>nd</sup>) viii) Best Student WIE Volunteer 'Syeda Areeba Fatima' (2<sup>nd</sup>)
2. 2019 IEEE R10 Outstanding Student Branch Award (2<sup>nd</sup> Place in Asia/Pacific)
3. 2019 Most Valuable Branch Counsellor Award in PSYWSC'19
4. 2020 IEEE MGA 2020 Outstanding Branch Counsellor Award (Dr. Asjad Amin)
5. 2020 IEEE MGA 2020 Darrel Chong Student Activity Award (IEEE AEPEX 2019)

# R10 Student Branch of the Month – Bangladesh University of Engineering & Technology

Prepared by: **Satyaki Banik, Chair for IEEE BUET Student Branch**

Lao Tzu said, “A journey of a thousand miles begins with a single step.” The journey of IEEE BUET Student Branch started on 19<sup>th</sup> November 1994 with a rich history of 25 years since inception. It was the very first student branch formed under IEEE Bangladesh Section, becoming the pioneer in IEEE student activities in Bangladesh. Over time, IEEE BUET Student Branch has become one of the largest and most vibrant student branches of IEEE Bangladesh Section, having more than 360 student members, a Women in Engineering affinity group and seven technical society chapters such as IEEE Industry Applications Society, IEEE Electron Devices Society, IEEE Power and Energy Society, IEEE Robotics and Automation Society, IEEE Signal Processing Society, IEEE Engineering in Medicine and Biology Society and IEEE Computer Society. All of these are creating multitude of opportunities for technical advancement of young students, as well as grooming them to become leaders in their fields.



## What we do: *Reaching the locals, connecting the global*



IEEE BUET Student Branch has been known for their vibrant and varying activities over the years. With more than 30 events on average each year, the SB organizes meaningful and member-driven programs all year around. The diversified set of events range from technical workshops, talks and seminars to humanitarian and professional skill development programs, and industrial visits strengthening industry-academia collaboration. Outreach programs for pre-university students have been one of the signature programs to inspire young minds to enjoy the art of engineering and take up engineering for further education.

The Student Branch has organized numerous Section and globally sponsored events; these include IEEE SPS Winter School 2019 on Multimodal Signal Processing, which was organized for the very first time in Bangladesh with the sponsorship from IEEE Signal Processing Society; Distinguished Lecture programs by IEEE Industry Applications Society and IEEE Electron Devices Society; IEEE Students’ Professional Awareness Conference (SPAC); Membership Development and Student Leadership Summit 2020 under the support of IEEE R10 Student Activity Committee; Teachers-in-Service Program 2019 etc. The Student Branch has hosted IEEE Bangladesh Section Student-Young Professionals-Women in Engineering-Members (SYWM) Congress 2018, IEEE Bangladesh Section Joint Student Branch Initiative 2019 and many more Section events. Large number of volunteers from IEEE BUET Student Branch has volunteered in several big events, such as the IEEE Region 10 Humanitarian Technology Conference 2017, IEEE WIE Leadership Summit 2018, IEEE Region 10 Symposium (TENSYP) 2020 etc.



## Contributions during the Pandemic

During the Covid-19 pandemic, IEEE BUET Student Branch has organized several technical, non-technical and humanitarian events to inspire, engage, and motivate IEEE members into doing something meaningful and impactful to the society. The Student Branch did a fundraising and donated a significant amount of money to

provide necessary food and clothing to a community of people who were in need. An online workshop series with five sessions named **Skillshop** was arranged along with IEEE BUET SB WIE Affinity Group on fundamentals of different engineering software. A webinar series named **Techtalk** was arranged wherein the main focus was 'Research and Innovation Challenges during Covid 19'. With more than 400 participants, seven speakers spoke about research opportunities in the pandemic era, topics ranging from signal processing, biomedicine, electron devices to taking care of mental health during the pandemic and embracing the new normal. IEEE BUET Student Branch and IEEE Bangladesh Section jointly organized two-day long virtual event titled **Student Membership & Leadership Summit**, with the support of IEEE Region 10 Student Activities Committee. A total of 364 participants from 39 countries from 10 different IEEE Regions attended the summit spread over the two days. IEEE BUET Student Branch was also one of the supporting student branches of **IEEE STEP 2020**, arranged by IEEE Young Professionals Bangladesh and IEEE Bangladesh Section.

### **Achievements & Recognitions: *Motivations to keep going forward***

IEEE BUET Student Branch has won several awards and accolades. Some of the recent achievements include:

- IEEE Darrel Chong Student Activity Award 2020 in Silver Category for "Outreach Program for Pre-University Students" (previously won the same award in 2018, Bronze category)
- IEEE Regional Exemplary Student Branch Award 2019
- IEEE Region 10 SAC Outstanding Volunteer Award 2018: Abhijit Biswas, Chair for IEEE BUET Student Branch (2017-18)
- IEEE Bangladesh Section Best Student Branch Award (2019, 2018, 2017, 2013)
- IEEE Bangladesh Section Best Student Volunteer Award (2019, 2018, 2017, 2016 (hon.), 2015 (hon.), 2013)
- IEEE Bangladesh Section Best Student Volunteer for Humanitarian Activity Award (2019, 2015)
- IEEE WIE Student Branch Affinity Group of the Year Award (2019, 2018 (hon.))
- IEEE R10 WIE Student Branch Affinity Group Award (2018, 2017 (hon.))



# R10 UPDATES





## 5. R10 UPDATES

### R10 Section Incentives 2020

Congratulations to the following Sections/Councils for making great efforts to organize activities and support their local IEEE communities.

No.	Council Name	Incentive (K USD)
1	India Council	2
2	Japan Council	1.5
3	Australia Council	1
4	China Council	1

No.	Large Section	Incentive (K USD)
5	Uttar Pradesh Section	4.5
6	Hyderabad Section	4.5
7	Pune Section	3.5
8	Bangladesh Section	3.5
9	Kerala Section	3.5
10	Bangalore Section	3.5
11	Kolkata Section	3.5
12	Tokyo Section	3.5
13	Victorian Section	3
14	Sri Lanka Section	3
15	Hong Kong Section	3
16	Malaysia Section	3
17	Madras Section	2.5
18	Indonesia Section	2.5
19	Singapore Section	2.5
20	Kansai Section	2.5
21	New South Wales Section	2.5
22	Bombay Section	1.5
23	Delhi Section	1.5
24	Beijing Section	1

No.	Medium Section	Incentive (K USD)
25	Western Australia Section	3.5
26	Karachi Section	3
27	Sendai Section	3
28	Hiroshima Section	3
29	Nagoya Section	3
30	Gujarat Section	2.5
31	Islamabad Section	2.5
32	Lahore Section	2.5
33	Queensland Section	2
34	Fukuoka Section	2
35	Tainan Section	2
36	New Zealand North Section	1

No.	Small Section	Incentive (K USD)
37	Vizag Bay Section	2.5
38	South Australia Section	2.5
39	Northern Australia Section	2
40	New Zealand Central Section	2
41	Republic of Philippines Section	2
42	Australia Capital Territory Section	1.5
43	Sapporo Section	1.5
44	Shikoku Section	1.5
45	Vietnam Section	1
46	Macau Section	0.5
47	Gwangju Section	0.5

No.	Subsection	Incentive (K USD)
48	Bhutan Subsection	1.5
49	Brunei Darussalam Subsection	0

# R10 Educational Activities Committee Update

Prepared by: **Chun Che Lance Fung, Chair for IEEE R10 Educational Activities Committee 2020**

At the time of writing this article, 2020 is drawing to a close and this serves as a reflection and summary of the work from the IEEE Region 10 Educational Activities Committee throughout the year.

These achievements would not have been possible without the dedicated services from members of the committee: Prof. Zuhaina Zakaria, A/Prof. Supavadee Aramvith, Prof. Yoot Khuan Lee, Dr. Iwan Kustiawan, Ms. Muhfizaturrahmah, Prof. Gao Yun An, Prof. Shaikh Fattah, Dr. Dall'Armi-Stoks, Giuseppina, Dr. Luo Sha, and in particular, Mr. Aravindhyan Anbazhagan and Ms. Purva Ekature for their help in the promotion of R10 educational activities, and running of webinars in the past months.



At the beginning of 2020, the Committee launched the R10 EAC Challenge and it received overwhelming response. After careful consideration by the members of the Committee, Winner and Runner-up were granted to IEEE Hong Kong Section and the IEEE SB NIT Durgapur respectively in the Pre-University Category; and the IEEE PES Malaysia Chapter and the IEEE University of Malaya SB respectively in the University Category. Eight other OU's also received Commendation Support for their proposals.

With regard to the R10 Outstanding Awards, it was a difficult task to choose from the number of excellent nominations. The choice of the judges finally settled on IEEE Education Society Chapter, Hyderabad Section, and Mohammad Hafiz Ismail of Malaysia Section for the Group and Individual Awards respectively.

When the lockdown and mobility restrictions began to affect all nations in the Region, 2020 IEEE President, Professor Toshio Fukuda and IEEE R10 Director, Professor Akinori Nishihara initiated the Project Reaching Locals to encourage R10 OU's to make educational resources available to the community in local languages. Many OU's in the Region acted swiftly and conducted numerous activities in the form of Webinars, videos, radio broadcasts, interviews, production of subtitles for IEEE flagship events, Workshops, Hackathon, MOOC and a range of innovative activities in countries such as Japan, India, China, Pakistan, Indonesia, Bangladesh, Malaysia and Hong Kong SAR. Languages used have included Japanese, Bengali, Malay, Hindi, Telugu, Urdu, Malayalam, Sindhi, Kannada, Gujarati and Chinese. Based on the submitted reports, it is exciting to learn that many thousands in the community have attended the events, and viewing of the recorded sessions on social media and different channels are continuing.

R10 EAC also initiated the R10 EA Virtual Social Media Challenge to encourage participation and promotion of IEEE EA on social media. Awards were granted to Akhya Katiyar (UP section) in the Popular Category, and Christian Innoval (Philippines Section) and Mallelu Sai Prashanth (Hyderabad Section) in the Innovative Category.

A total of four webinars/forum have also been conducted and facilitated by R10 EAC on 20<sup>th</sup> June 2020 - "IEEE EA Resources and Getting Involved"; 24<sup>th</sup> July 2020 - "Launch of Project Reaching Locals"; 8<sup>th</sup> August 2020 - "IEEE Code of Ethics & Global Initiative on Ethics of Autonomous & Intelligent Systems" and on 20<sup>th</sup> September 2020 - R10 SYWL Congress with a session on updates and presentations from several sections (see report at IEEE 2020 SYWL, EA Track)

The IEEE 2021 R10 EAC will be chaired by Professor Preeti Bajaj and she has lined up great plans for the region on educational activities, just watch this space! I wish you all a prosperous and safe 2021 and thanks again to all R10 EAC members, volunteers and participants who have contributed towards the educational goals of IEEE. You have helped advancing technology for the benefits of humanity!

# R10 Webinar: A Dialogue with IEEE Management Council Speakers

Organized by R10 Strategic Planning Committee

Prepared by: Ewell Tan, Project Manager for IEEE Asia-Pacific Ltd.



Region 10 volunteer leaders have expressed their views on a survey conducted by R10 Strategic Planning Committee in 2019 to have a better connection with the IEEE management leaders. In response to the feedback, R10 Strategic Planning Committee led by Prof. Byung-Gook Park has initiated a Webinar on 27<sup>th</sup> October 2020 in order to provide an opportunity for our R10 volunteers to have an interactive dialogue session with the IEEE Management Council leaders.

Join this webinar to hear from our IEEE Management Council Invited Speakers and have a dialogue session to get more insight about IEEE!

## Our Invited Speaker



**Dr. Cherif Amirat**  
Chief Information Officer  
IEEE



**Cecelia Jankowski**  
Managing Director  
IEEE Member and Geographic Activities



**Prof. Akinori Nishihara**  
IEEE R10 Director



**Jamie Moesch**  
Managing Director  
IEEE Educational Activities



**Mary Ward-Callan**  
Managing Director  
IEEE Technical Activities



**Moderator**  
**Prof. Byung-Gook Park**  
IEEE R10 Strategic Planning Committee

Region 10 was very honored to have invited IEEE Chief Information Officer (CIO), Dr. Cherif Amirat; IEEE Member and Geographic Activities (MGA) Managing Director, Ms. Cecelia Jankowski; IEEE Educational Activities (EA) Managing Director, Mr. Jamie Moesch and IEEE Technical Activities (TA) Managing Director, Ms. Mary Ward-Callan to share their strategic direction, new initiatives and to provide an insightful view of their respective departments and expertise.

Prior to this webinar, Region 10 has opened the door to welcome questions from the R10 organizational units' volunteer leaders; this is to ensure that all volunteers have the opportunity to address their concerned questions. During the webinar, Prof. Byung-

Gook Park gave a welcome message and highlighted the objective of this event. After this welcome, Region 10 Director, Prof. Akinori Nishihara graced the event by delivering an opening address.

Dr. Cherif, IEEE CIO was the first presenter. He highlighted the launch of IEEE APP which represents a global gateway to IEEE and introduced the NextGen Finance, which is one of the 2020 IEEE Board's strategic initiatives. This NextGen platform will streamline and simplify the existing financial process; most importantly, it will advance the business activities and provide operational efficiency.

Next, IEEE MGA Managing Director, Ms. Cecelia shared about the IEEE MGA specific strategies and operational responsibilities. Some IEEE volunteer tools were highlighted, for instance, IEEE Centre for Leadership Excellence (CLE), IEEE vTools, IEEE Volunteering Portal, IEEE Badges and etc. These resources are essential in providing support to the volunteers in managing their local IEEE communities.

Thereafter, IEEE EA Managing Director, Mr. Jamie talked about the educational programs and capabilities that will increase the impact and benefit our members, especially on the continuing education and lifelong learning that will enhance the value of IEEE membership and value proposition.

IEEE TA Managing Director, Ms. Mary Ward-Callan also provided an insightful view of technical activities strategic framework with new technologies, new audience group, new delivery method and new contents. With the new change of landscape due to the global pandemic, IEEE has supported many virtual and hybrid events to keep its members and communities engaged.

Each of the speaker’s presentations was followed by an interactive Q&A session to make sure that the concerned topics and questions were answered. The webinar was fruitful and was concluded by R10 Strategic Planning Committee Chair, Prof. Byung-Gook Park with closing remarks.

Region 10 has wrapped the event by sharing the useful materials for the benefit of its members on IEEE R10 website. The recorded webinar can be found on IEEE Region 10 Facebook page.





# SECTION AND SUBSECTION ACTIVITIES



## 6. SECTION AND SUBSECTION ACTIVITIES

### IEEE Bangladesh Section

#### IEEE Bangladesh Section Technical Expert Forum

**S M Saiduzzaman, Newsletter Editor for IEEE Bangladesh Section**

On 26<sup>th</sup> September 2020, IEEE Bangladesh Section organized the "IEEE Bangladesh Section Technical Expert Forum". As the Chair of IEEE Bangladesh Section, Prof. Celia Shahnaz brainstormed, led and launched this initiative. The forum was live on Facebook from the IEEE Bangladesh Section Facebook Page. This program was open for all, and around 900 people watched the forum via Facebook live.



The objectives of this forum were following:

- To foster research and innovation
- To promote industry-academia collaboration
- To drive membership grade elevation (IEEE Senior Membership)
- To mentor graduate students for scholarships, travel grants and graduate admission
- To create cell to nurture social entrepreneurship and start-ups
- To advance Women by Skill development
- To enhance member engagement in corporate, public and private industries

Members of the IEEE Bangladesh Section are encouraged to join the forum, which consists of four major technical divisions focusing on Communication, Computer, Electronics, and Power. IEEE Bangladesh Section will be strengthening the initiative for Senior Member Elevation, although the first training of this year was conducted on 30<sup>th</sup> January 30 2020 that encouraged many to apply for senior memberships throughout the year

IEEE Bangladesh Section will invite experts from the industry to build a strong industry-academia collaboration. Members of the IEEE Bangladesh Section Technical Forum will recommend the possible industry experts. These experts will also be a part of the IEEE Bangladesh Section Technical Forum. These industries will be approached for internships and research funding.

The other points discussed were to launch new technical chapters to address and include more diverse research enthusiasts in IEEE Bangladesh Section, to mentor graduate students for scholarships, travel grants and graduate admission, to create a cell to nurture social entrepreneurship and start-ups, to advance Women by Skill development and to enhance member engagement in corporate, public and private industries. At last, it was decided that the forum members will be holding multiple meetups and other synergistic activities from time to time in order to strengthen the community and ensure the betterment of the technical professionals for a post-pandemic world. Prof Celia Shahnaz, Chair for IEEE Bangladesh Section, presided over the whole session. The program was ended by a note of thanks by the Chair.

IEEE Members present in the meeting appreciated this milestone effort in creating the IEEE Bangladesh Section Technical Forum. They opined that it will enhance collaboration among technical experts and can create a borderless platform to share recent research updates. It will also invigorate the efforts towards the 4<sup>th</sup> industrial revolution for which technical assistance and collaboration would be a dire need.

## IEEE Day Observations - Dreams, Dialogs, and Directions for a Better Tomorrow

Celia Shahnaz, Chair for IEEE Bangladesh Section

Considering the COVID-19 pandemic, IEEE Bangladesh Section observed IEEE day through full virtual events focusing on “Dreams, Dialogs, and Directions for a Better Tomorrow”. The new mode of these events was “Interactive Dialogs”, instead of conventional continuous talks.

The five-day program consists of the following:

- Student Branch Activities: 6<sup>th</sup> October 2020
- Student Branch Technical Chapter Activities: 7<sup>th</sup> October 2020
- Women in Engineering Activities: 8<sup>th</sup> October 2020
- Technical Society Chapter Activities: 9<sup>th</sup> October 2020
- Members and Young Professionals Activities: 10<sup>th</sup> October 2020.



The inauguration ceremony on October 6<sup>th</sup> was adorned with Prof. S. N. Singh, FIEEE, Vice-Chair, Technical Activities, IEEE Region 10 as the inaugural speaker of the event. Another notable speaker was Prof. V. R. Singh, LFIEEE. Parts of the third and fourth day sessions were held in Bangla Language following the Reaching Locals project, an initiative of IEEE President & CEO (2020) Dr. Toshio Fukuda.

## The First Women in SIGHT Summit (WISE) by IEEE Bangladesh Section and IEEE SIGHT FLASH Bangladesh

Celia Shahnaz, Chair for IEEE Bangladesh Section



To celebrate 2020 IEEE SIGHT Week (29<sup>th</sup> November - 6<sup>th</sup> December 2020), IEEE Bangladesh Section and IEEE SIGHT FLASH Bangladesh organized the first Women in SIGHT Summit (WISE) on 6<sup>th</sup> December 2020. Dr. Celia Shahnaz, Chair for IEEE Bangladesh Section, IEEE SIGHT FLASH, and Women in SIGHT Working Group (2020) has led this initiative to engage more women in SIGHT/HAC projects/events.

Speakers and panelists from 3 IEEE Regions and 11 Sections joined the Summit. More than 65 participants from over 13 Sections from R10 and R9 joined the Summit. Sampathkumar Veeraraghavan, 2020 Chair for IEEE SIGHT and 2021 Chair for IEEE HAC was chief guest, and Jennifer Castillo, 2021 Chair for IEEE WIE was guest of honor. Other panelists

were Antuanett Yomyra Damian Gomez (IEEE Peru); Muhfizaturrahmah (IEEE Indonesia); Iti Saha Misra (IEEE Kolkata); Nadiyah Hussein (IEEE Malaysia); Aarti Karande (IEEE Bombay); Pia Torres (IEEE Argentina); Thiago Alencar (IEEE South Brazil) and Hana Siddiquee from New York, USA. Shaikh Fattah (2020 Education Chair for IEEE HAC) presented IEEE RAS-SIGHT funded project of SIGHT FLASH for designing and building of disinfection robots to handle Covid 19. Women interested and engaged in SIGHT/HAC activities have also presented their works in WISE.



## IEEE Gujarat Section

Chirag Paunwala, Secretary for IEEE Gujarat Section

### National Seminar on Computer Vision & Image Processing (NaSCoVIP2020)



With the explosion of Internet technology and graphic engines, there has been a massive growth in the research area of computer vision and image processing. While the field of image processing deals with the processing of digital images that are two-dimensional entities, computer vision adds the third dimension by computing the object's depth. A three-day national seminar was held from 10<sup>th</sup> September 2020 to promote research and developmental activities in India, with

around 80 participants. The seminar fortifies the computer vision and image processing and related fields by assembling experts and researchers in the area. The seminar's primary goal was to promote scientific information exchange amongst experts, researchers, developers, engineers, students, and practitioners working in the country. The scientific program of the seminar consists of presentations by leading experts worldwide in the field of computer vision and image processing. The experts addressed the recent developments and trends in the fields.

The speakers for the event were as follows:

- Ms. Mukta Joshi, Group leader Image Guided Therapy Systems R&D, Philips, Netherlands. Title of talk: *Advances in medical imaging for diagnosis and treatment*
- Dr. Chintan Parmar, Senior Expert, Oncology Novartis, Institutes for Biomedical Research, USA. Title of talk: *AI applications for medical imaging biomarkers*
- Prof. Chang-Hyun Oh, Professor, Department of Electronics and Information Engineering, Korea University. Title of talk: *Real-Time MR Thermometry using Deep Neural Network*
- Mr. Akbar Doctor, Principal Test Engineer, Fresenius Medical Care, USA. Title of talk: *Test Automation-Medical Devices*
- Prof. Ram Bilas Panchori, Professor IIT Indore. Title of talk: *Detection of human brain disorders using novel machine learning approaches*
- Prof. Tolga Kaya, Professor, Sacred Heart University, Fairfield, USA. Title of talk: *Validation Study of a Dry Hand Cleaner as a Potential Hand Sanitizer*

### Self-Branding for Professional Awareness

The Webinar on Self Branding for Professional Awareness, held on 10<sup>th</sup> April 2020, was aimed at professionals and students who wanted to further their self-brand and image, thus, improving their future career aspects. Mr. Deepak Bhatt, an influential individual who is currently the Deputy General Manager (HR & Strategy Development) at Astron Packaging Limited, was the speaker of a day to an audience of 75 participants. The speaker explained various methods of promoting oneself, be it on social media or in real life. The main crux of the introduction was the value and increasing importance of self-branding in today's competitive world. The Webinar was fruitful for the participants as it resulted in discussions that are of paramount importance. With this session, all participants left with a sense of satisfaction, loads of knowledge and clarity about the matter at hand.



## WiSe (Women in Sensors) Week 2020

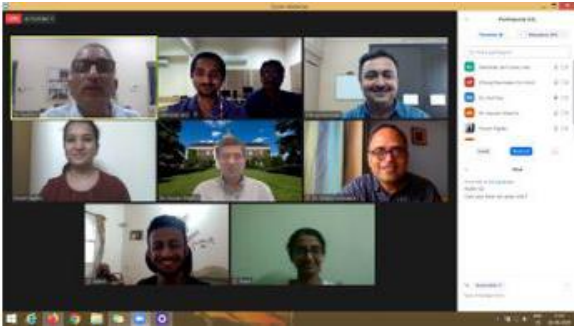

In this WiSe Week, held on 9<sup>th</sup> April 2020, we are reaching out to students and professionals to promote women in sensing technology, in particular, and in STEM, in general. We hope that such focused occasions would provide the opportunity to create communities for facilitating knowledge sharing and offering support for women in this domain.

Besides these, we had also planned a networking session, quiz and some impromptu contests and prizes through virtual platform. All these highly interactive sessions were designed to foster discussions, networking, collaboration, knowledge sharing, fun and above all sensitizing the attendees for Women in Sensors. 128 participants joined the event.

## IEEE Hiroshima Section

### IEEE Metro Area Workshop 2020 in Hiroshima

**Chisa Takano, Secretary for IEEE Hiroshima Section**

On 16<sup>th</sup> October 2020, "Metro Area Workshop (MAW) 2020 in Hiroshima" was held at Hiroshima Garden Palace hotel in Hiroshima City. In order to prevent COVID-19 infection, a hybrid system of on-site and online meetings was adopted. At this year's MAW, we invited 7 speakers to deliver special talks regarding advanced information and communication technology that supports social infrastructure in the Mobile era, under the theme of "IoT created by Mobile, Mobility accelerated by IoT". We



were very pleased with the interesting and impactful presentations on the latest communication technologies in high-speed mobile objects such as cars and railways, and the development issues of various communication systems surrounding IoT. There were many participants from many companies, local governments, and universities: 56 participants at the venue, and 118 participants online, for a total of 174 participants. The group photo was taken with the online speakers and online participants. The exchange meeting after the workshop ended with great success with 46 participants.

## IEEE Karachi Section

### IEEE Day's and IEEE POCO 2020-IEEE Karachi Section

**Dr. Bhawani Shankar Chowdhry, Chair for IEEE Karachi Section & M. Rafay Shaikh, Section Student Representative for IEEE Karachi Section**

#### IEEE Day 1.0: Webinar on Leadership in IEEE (13<sup>th</sup> October 2020)

We all know that IEEE is not just renowned for its technical facets but is also widely known for cultivating highly motivated and skilled leaders equipped with the right arsenal to groom their way through their careers and professional lives. And IEEE Day 2020 is the best opportunity to guide students about what IEEE offers its members in terms of professional growth and what it's like to be an IEEE leader. As such, IEEE Karachi Section Student Activities Committee organized a Webinar as part of the IEEE Day 2020

celebrations on 13<sup>th</sup> October 2020 from 8:00 - 9:00 pm with the profound and well-known Engr. Parkash Lohana, Chair of R10 Membership Development Committee, as the guest speaker.

Engr. Parkash Lohana gave a very motivational talk to student members and potential volunteers inspiring them about the vast number of resources and opportunities available to IEEE members and the benefit of membership in terms of leadership and professional growth. Around 60 participants attended the Webinar including prominent guests.



### **IEEE Day 2.0: Technology Awareness Programme (16<sup>th</sup> October 2020)**

IEEE Day 2.0 was celebrated virtually. The main theme of the event was centered around TAP - Technology Awareness Programme. Students were motivated and felt responsible for the need to understand and participate in technological revolution, encouraging each other to serve humanity. There were professional speakers invited from national and international backgrounds, delivering Webinars upon emerging technologies and its importance.

### **IEEE Day 3.0 – Grand Celebration (17<sup>th</sup> October 2020)**

IEEE Karachi Section Student Activities Committee organized a third event to celebrate IEEE Day 2020. This was our first physical event of 2020. All Student Branch Executive Officers were invited to come together on the occasion of IEEE Day 3.0 Celebrations on 17<sup>th</sup> October 2020 from 10:00 - 12:00pm. Almost 50 participants enthusiastically attended the event. The event involved a grand meeting followed by an interactive session and a fabulous cake-cutting ceremony. Several honored guests including Dr. Bhawani Shankar Chowdhry, Chair of IEEE Karachi Section, Dr. Tariq Rahim Soomro, Vice Chair of IEEE Karachi Section and Engr. Parkash Lohana, Chair of R10 Membership Development Committee.

This event proved to be a splendid opportunity for Student Branch ExCom Members to interact and intermingle with each other and also become familiar with prominent members of the Section and SAC. They were also able to discuss important matters regarding the significance of their role as IEEE members and the IEEE community as a whole.

### **IEEE POCO by IEEE Karachi Section in Collaboration with IEEE R10 (21<sup>st</sup> November 2020)**

IEEE Karachi section organized a virtual workshop IEEE PANEL OF CONFERENCE ORGANIZER (POCO) with the collaboration of IEEE Region 10 on 21<sup>st</sup> November 2020 for the universities of all over Pakistan with an aim to help them know how to organize topflight conferences by following the standards provided by IEEE. IEEE POCO also provides complete information for making an evaluation plan for research papers.

The event started with the name of Almighty Allah and recitation of Kalam E Quran E Paak. After that Dr. M. Shahid Shaikh initiated the event formally by his opening note. At 9:45 am the honorable Chair of IEEE Karachi Section Professor Dr. Bhawani Shankar Chowdhry addressed the audience regarding the significance of the conference which then led to the oration of Dr. Shahab Siddiqui in which he shared

his experience from the conferences he had gained throughout his journey. After that, Dr. Shahid Shaikh provided a brief overview on the role of IEEE conference MOU which followed by the discussion of how to involve IEEE student volunteers by Sir Atif Fareed. Afterwards Section Treasurer Moiz Rehman Memon briefed the audience about the financial issues faced by conference organizers. He also explained how to make a budget plan and how the bank proceeds in its proceedings.

IEEE Karachi Section Vice Chair Dr. Tariq Soomoro delivered his thoughts about conference review process tools where he also told the audience how to avoid plagiarism in papers. Dr. Asim Ur Rehman, Section Secretary shared insights about the gravity of the call for papers. IEEE Xplore education coordinator Dr. Sadiq Ali Khan talked about IEEE Xplore's importance, and provided information about the use of its tools. Our worthy Guest of Honor from India, Dr. S. N. Singh, R10 Vice Chair Technical Activities, delivered his disquisition about the development of conference theme based on current issues. After which there was a panel discussion involving Dr. Tariq Somoroo, Moiz Rehman Memon, Dr. Saeed Khan Abroo, and Dr. S. N. Singh, moderated by Engr. Parkash Lohana. At last Section Chair Dr. Bhawani Shankar and Engr. Parkash lohana ended the day with a thanking note.

## IEEE Madras Section

### N. Kumarappan, Chair for IEEE Madras Section

#### R10 SAC Sponsored Leadership Insight Program

IEEE Madras Section & IEEE R10 organized the Leadership Insight Program during 12<sup>th</sup> & 13<sup>th</sup> September 2020 with 62 participants. Dr. N. Kumarappan, Chair for IEEE Madras Section highlighted the importance of leadership in students during the inaugural.

On day 1, Mr. Vidya Shankar G, Founder and CEO, Only Success Academy shared about “How to build up a professional career and stories behind success”. Mr. Harish Bharadwaj, CEO, HUM Consulting talked about “Creative thinking and decision making”. Mr. Charles, ZOHO HR Leader, talked about “Smart Work”.

On day 2, Section Chair, Dr. N. Kumarappan delivered a talk on “Awareness for Student and Professional Members”. Dr. Preethi Bajaj, Vice Chancellor, Galgotias University gave a talk on “Roles in IEEE after graduation”. Mr. Madhav Negi, CTO, DXC Technology India, delivered a talk on “How to be a better Leader?”.



#### IEEE Madras Section R10 POCO 2020

IEEE Madras Section organized an IEEE R10 sponsored Panel of Conference Organizers (POCO) 2020 on 10<sup>th</sup> and 11<sup>th</sup> October 2020, with 58 participants. The chief guest Dr. Sri Niwas Singh, Chair for IEEE India Council explained about educating the conference organizers in maintaining the quality.

On Day 1, Dr. T. Thyagarajan, Dean, MIT, Anna University gave a presentation on “Key Issues and Challenges in Organizing IEEE Conference”. Dr. Amit Kumar, Chair, IEEE Hyderabad Section talked on “Technical Program Overview”. Dr. N. Kumarappan Chair, Madras Section talked about “Publications in IEEE Conference and Journals”.

On Day 2, Mr. Puneet Kumar Mishra, Secretary, IEEE India Council gave a presentation on “Financially Co-Sponsored Conference and Conference Success Stories”. Dr. D. Devaraj gave a presentation on “Planning an IEEE Conference and Conference Proposal Submission”.

### IEEE Madras Section Student Branch Officers Meet – 2020

IEEE Madras Section & SRM Valliammai Student Branch organized the IEEE Madras Section Student Branch Officers Meet on 7<sup>th</sup> November 2020. Dr. N. Kumarappan, Chair for IEEE Madras Section explained about IEEE Student Membership Awareness. The Chief Guest Mr. Deepak Mathur, Director-Elect, IEEE Region 10 gave insight about the importance of IEEE. Mr. S. Nandan, SAC Chair, IEEE Kerala Section gave a talk on “Volunteering with IEEE”. Mr. B. Ashvanth, Treasurer, IEEE Madras YP imparted knowledge about Word Press Web Designing. Mr. M. I. Abdul Halik, ExCom Member, IEEE Madras YP conducted virtual treasure hunt and quiz competition.

### IEEE Day Celebration

IEEE Madras Section organized IEEE Day 2020 technical get together hosted by Sri Ramakrishna Engineering College, Coimbatore on 18<sup>th</sup> October 2020, with 130 participants. Dr. N. Kumarapan, Chair for IEEE Madras Section shared insights about the activities and IEEE project funding. He also congratulated all members for the membership retention development award 2020.

The chief guest, Dr. S. K. Ramesh, Professor of Electrical and Computer Engineering at California State University, Northridge USA shared his views about the abundant opportunities provided by IEEE. Dr. M. Ponnavaikko, former Chairperson of IEEE Madras Section and India Council shared his views on how IEEE helps one to groom and grow professionally and socially. The guest speaker Dr. N. R. Alamelu, former Chairperson of IEEE Madras Section provided the awareness about the best practices and opportunities in IEEE. Aravindhnan Anbazhagan, Chair for IEEE Madras YP hosted the quiz.

## IEEE Malaysia Section

### IEEE Malaysia Tech Insights and Student Icon Initiatives Aired on National Radio Station

**Fakhrul Zaman Rokhani, Executive Committee for IEEE Malaysia Section**



The IEEE Malaysia Tech Insights and Student Icon are initiatives led by the Strategic Communication committee of IEEE Malaysia Section, with a smart partnership with leading national radio station Bernama Radio. These programs were brought live to radio listeners over the air and the Facebook Live (FBLive) on the Bernama Radio’s CampusLife and I-GEN segments, respectively. The Tech Insights and Student Icon are strategic initiatives through mass communication to increase IEEE’s brand awareness and online presence and strengthen the IEEE’s credibility as a leading contributor in technology in Malaysia. The programs are also part of the Reaching Locals initiative as it was conducted in the local Malay language.

Tech Insights initiative highlights IEEE Malaysia Section’s widespread collection of technology and advanced technology developed by its members that bring benefits to society locally and humanity in general. Three episodes aired by Bernama Radio were (1) Early Detection Technology for Diabetic Retinopathy by Dr. Fawnizu Azmadi Hussin (IEEE Malaysia Section Chair) on 14<sup>th</sup> July 2020, (2) Fall

Prevention Technology for Senior Adults by Dr. Alpha Agape Gopalai and Ir. Dr. Siti Anom Ahmad (EMBS Chapter Chair and Chair-Elect) on 11<sup>th</sup> August 2020, and (3) PerfectRide: Technology-Assisted Safe Driving by Dr. Sazalinsyah Razali (SMC & RAS Chapters ExComm) on 25<sup>th</sup> August 2020.

Student Icon initiative promotes the voice of IEEE Malaysia Section students and how IEEE shapes their leadership and personality. The first episode aired on 27<sup>th</sup> October 2020 was on Holistic Character Development, given by the Chair of IEEE Student Branch Curtin University Malaysia, Nurul Ain Hamizan, and Strategic Communication Student ExComm, Muhammad Aiman Hakim Moktar, hoping to inspire their peers - young generations in shaping their leadership and personality.

## IEEE Sri Lanka Section

### Recent Activities of IEEE Sri Lanka Section

#### Windhya Rankothge, Secretary for IEEE Sri Lanka Section

IEEE Sri Lanka Section community has been challenged by the COVID-19 pandemic, a global health crisis that has impacted many members of the IEEE family. The temporary closure of educational and professional institutions during pandemic has abruptly transformed the IEEE Sri Lanka Section activities landscape in favor of online activities. Despite the challenges, the Section has conducted several online activities, including webinars, tech talks, and online competitions.

A Distinguished Lecture Program (DLP) on “Wireless Grid Integration of EVs for V2G Applications” by Prof. Udaya Madawala (University of Auckland) was held on 1<sup>st</sup> August 2020, with around 100 participants as an online event. Even though Electric Vehicles (EVs) are considered as a remedy to air-quality and depletion of fossil reserves, to address these concerns, EVs require an efficient, compact, and reliable power electronic interface for grid integration. The DLP discussed trends in the grid integration of EVs. The IEEE Sri Lanka Section also conducted the IEEE Electronic Design Competition 2020 as an online competition. It is an annual event of the Section that targets to improve the knowledge and design skills of Sri Lankan undergraduate. The 1<sup>st</sup> round was conducted on 25<sup>th</sup> August as an online competition. 38 teams participated in the competition, where they were required to design and develop a given task using a simulation environment.

IEEE BOOST 2020, which was an online awareness program, was conducted on 10<sup>th</sup> and 11<sup>th</sup> October 2020, with the participation of 300 student members. It provided an opportunity for the student members of IEEE Sri Lanka Section to interact with the leadership of IEEE Sri Lanka Section and senior volunteers of IEEE. The program included a variety of activities based on professional and membership developments along with enthusiastic competitions.



## IEEE Tokyo Section

### IEEE Japan SYWL Workshop in Hiroshima (and Online)

**Takashi Yoshida, Chair for IEEE Young Professionals AG Tokyo**

IEEE Japan SYWL Workshop in Hiroshima (and Online) was held at Hotel Hiroshima Garden Palace and via Zoom meeting on 17<sup>th</sup> October 2020. This workshop was organized by the committee members from Student Branch, Young Professionals, Women in Engineering and Life Member Affinity Groups of all over Japan. There were 42 participants, almost all of them are IEEE members.



In spite of the COVID-19, more than 20 IEEE members gathered at the onsite venue. It was challenging to hold the onsite event together with the online event. Nevertheless, observations were made on some points that needed to be improved such as the difficulty in conveying the excitement of the on-site side to the online side. Despite the difficult situation in connecting each member, we will revitalize IEEE's activities by taking advantage of each merit for both online and local activities.

## IEEE Western Australia Section

**Amit Kunwar, Newsletter Editor for IEEE Western Australia Section**

### International Conference on Smart Grids and Energy Systems (SGES 2020)



The 2020 International Conference on Smart Grids and Energy Systems (SGES 2020) was broadcasted virtually from Perth, Australia, on 23<sup>rd</sup> to 26<sup>th</sup> November 2020. The executive committee of the conference consisted of General Chair, Professor Fushuan Wen from Tallinn University of Technology, Estonia, and Technical Committee Chair, A/Professor Farhad Shahnian and Secretary, Dr. Moayed Mogbel from IEEE Western Australia Section. Additionally, the organizing committee of the conference consisted of 19 colleagues from Australia, China, Hong Kong, and Singapore. The

technical program of the conference was supported by 20 universities in 10 countries. The colleagues from the IEEE Western Australia Section, IEEE Western Australia Industrial Electronics Society (IES) Chapter, and the IEEE Murdoch University Student Branch were the key local organizers of the conference at Perth.

This online conference had attracted over 200 delegates from 35 countries who attended this event over a 4-day period. Despite COVID-19 has changed many of our current practices in 2020 including face-to-face conferences, the organizers were very thankful to all authors and delegates who supported the idea of arranging the SGES 2020 conference on-line.

SGES 2020 had received just below 280 submissions from 42 countries with 610 co-authors across six continents. Authors from China, Australia, Japan, the United States, Germany, India, Bangladesh, the

United Kingdom, Korea, Malaysia and Brazil had respectively submitted the highest number of papers to the Conference. In total, 180 papers from 556 authors were finally accepted and scheduled in the Conference Program. Of these authors, 485 have one accepted paper, 50 have two accepted papers and 21 have 3 or more accepted papers. The accepted and scheduled papers were presented in 23 oral sessions over a 4-day period. The conference also provided 6 Best Student Paper Awards to the top presented papers.

In addition, the Conference had a very strong technical program, including 12 distinguished keynote speakers from Australia, China, the US, Canada, Denmark, and Greece. Furthermore, one industry forum, and 5 tutorial sessions were also arranged and presented during the conference.

The comments and feedback received from the Conference delegates and invited guests at the end of the conference were extremely positive and encouraging, and all delegates congratulated the organizers for arranging a successful event.

### IEEE DAY 2020 NETWORKING EVENT, PERTH

IEEE Western Australia Section organized a networking event on 20<sup>th</sup> October 2020 to celebrate IEEE Day and provide a networking opportunity for its members. The event was organized at QT Perth Hotel in the CBD, and was well attended by IEEE members with 80 registrations and participation from over 60 members.

Section Secretary, Dr. Shoeb Md Asaduzzaman, delivered a welcome speech; and Section Chair, A/Professor Farhad Shahnian, presented the activities and achievements of the section.

Additionally, Dr. Chun Che Lance Fung, 2021/2022 R10 Director-Elect, and Dr. Adam Osseiran, Industry Liaison of the Western Australia Section, also delivered speeches. Trophies for the chapters with the highest number of technical activities and the highest membership growth for 2019/2020 were also presented at the event.

The IEEE Day networking event was a great success, with the participating members celebrating the IEEE day and enjoying the opportunity of socializing with each other.







# AFFINITY GROUP AND CHAPTER ACTIVITIES



## 7. AFFINITY GROUP AND CHAPTER ACTIVITIES

### IEEE Women In Engineering AG Bangladesh

Workshop series on “Web Design from Scratch: HTML, CSS & Bootstrap”

Fardeen Mahbub, Publication Coordinator for IEEE AIUB Student Branch



On 16<sup>th</sup> and 17<sup>th</sup> October 2020, the IEEE AIUB SB WIE AG in collaboration with the IEEE AIUB SB organized a two-day long workshop series, titled “Web Design from Scratch: HTML, CSS & Bootstrap” through the virtual platform of CISCO WEBEX Meeting. The first day of the series titled, “Learning HTML” was conducted by Victor Stany Rozario, Assistant Professor, FSIT, AIUB where he highlighted the theoretical ideas of HTML and its importance in web development. The second day of the workshop titled, “CSS & Bootstrap” was conducted by Md. Tariqul Islam Manon, RWD Mentor & Career Advisor, CodesTrust Bangladesh by emphasizing the concepts of CSS and its importance. Also, from 19<sup>th</sup> to 28<sup>th</sup> October 2020, a Front-End Web Design Competition was organized where participants were given a sample task by the means of their creativity and designing skills. A total of 159 individuals participated in the series and winners were awarded tokens of appreciation.

### Breast Cancer Awareness: From Engineering Point of View

Anamika Bhakta, Industrial Activity Coordinator for IEEE Bangladesh Section & Chair for IEEE WIE AG Bangladesh

Following the Reaching Locals project, an initiative taken by IEEE President Dr. Toshio Fukuda, and nurtured by 2019-2020 IEEE Region 10 Director Dr. Akinori Nishihara, WIE AG IEEE Bangladesh Section along with IEEE Bangladesh Section organized “Breast Cancer Awareness: From Engineering Point of View” program on 30<sup>th</sup> October 2020 from 8pm to 9pm. The live program was conducted in English. The whole speech was then re-recorded in Bangla Language and published on the IEEE Bangladesh Section page so that it can reach a greater number of people. 25 participants joined from 6 IEEE FB pages where the event was publicized through Facebook Live. The resource person was Dr. Samia Mubin, Associate Professor, Surgical Oncology Division, Department of General Surgery, Bangabandhu Sheikh Mujib Medical University(BSMMU), Bangladesh.



### IEEE Women In Engineering AG Sendai

The 3<sup>rd</sup> Anniversary Ceremony of Sendai WIE

Qiaowei Yuan, Chair for IEEE WIE AG Sendai

The 3<sup>rd</sup> anniversary of IEEE WIE Sendai was virtually celebrated with 37 attendances on 31<sup>st</sup> October 2020, which was delayed from the original schedule in April due to the COVID-19 pandemic. The anniversary consisted of two parts focusing on the topic of “State of the Art Technologies Devoted to

Society 5.0". In the first part, three special talks were provided by Dr. Akinori Nishihara (R10 Director), Prof. Noriko Osumi (Tohoku University), Prof. Akira Ando (Tohoku University), respectively. The second part started by introducing the activities of each Japanese WIE, and then all attendees were divided into several groups, discussing the importance of Society 5.0 that Japan should aspire to and some interesting topics related with a smart tech society. The pandemic prohibited peoples from connecting in person, but the anniversary reconnected our technology groups tightly. Our event definitely was an initial practice to integrate cyber space (virtual space) and physical space (real space).



## IEEE Young Professionals AG Sapporo

### Newsletter of JAPAN YP Meet 2020

**He Li, Chair for IEEE Young Professionals AG Sapporo**



The Japan YP meet was held after the IEEE Japan SYWL Workshop in Hiroshima (and Online) 2020. YP members from all Sections got together again and discussed the status and future plans of each YP groups. In the group discussion, representatives of YP from each Section introduced the development and problems at hand. Nagoya YP considered that it was difficult to hold events to broaden knowledge. Tokyo YP indicated that there was still a small number of active members despite carrying out many events. Compared with the situation in India, it should be attributed to the different evaluation methods and work styles. Sendai YP considered expanding the coverage of the YP group in Tohoku as an important developing target in the future. Sapporo YP, which was established this year, thought on how to increase regional awareness, and developing cooperation between enterprises would be the initial development focus.

## IEEE Young Professionals AG Sendai

### The Kickoff Event of Sendai YP

**Kota Oikawa, Member for IEEE Young Professionals AG Sendai**

IEEE Young Professionals Affinity Group Sendai conducted the kickoff event online on 30<sup>th</sup> October 2020, with 16 participants. In the general meeting and the founding commemoration meeting, current activities and next year's activities were reported and the officers for the next term were approved. Then after, a memorial lecture by Mr. Ichikawa of HarvestX, and an online exchange party were carried out.



# IEEE Life Members AG Tokyo

## LMAG Tokyo's 10<sup>th</sup> Anniversary Symposium and IEEE Day Celebrations

Naohisa Ohta, Secretary for IEEE Life Members AG Tokyo

The symposium was held online (Zoom Webinar) at 14:00-17:00 on 8<sup>th</sup> October 2020 (Thursday) sponsored by IEEE Tokyo Section and IEEE LMAG Tokyo, and co-sponsored by Japan Council, Tokyo YP, JC WIE, Tokyo SAC, and Tokyo Section TPC. Altogether 70 people participated; 7 people of the steering committee worked at the main venue in Tokyo and the others participated online. The symposium started with an opening address by Dr. Imai, LMAG Tokyo Vice Chair. First, Dr. Tokuda, Tokyo Section Chair, gave a sponsor's remark on LMAG Tokyo's 10<sup>th</sup> anniversary. Then, Dr. Takano, LMAG Tokyo Chair, delivered an address and introduced LMAG Tokyo's activities for 10 years highlighting the first experience of each activity. Next, Dr. Fukuda, IEEE President and Dr. Nishihara, R10 Director delivered congratulatory speeches for the 10<sup>th</sup> anniversary. Also, all other LMAG Chairs in Japan, Dr. Nakamura of Kansai, Dr. Umeno of Nagoya and Dr. Mizuno of Sendai, gave congratulatory addresses.

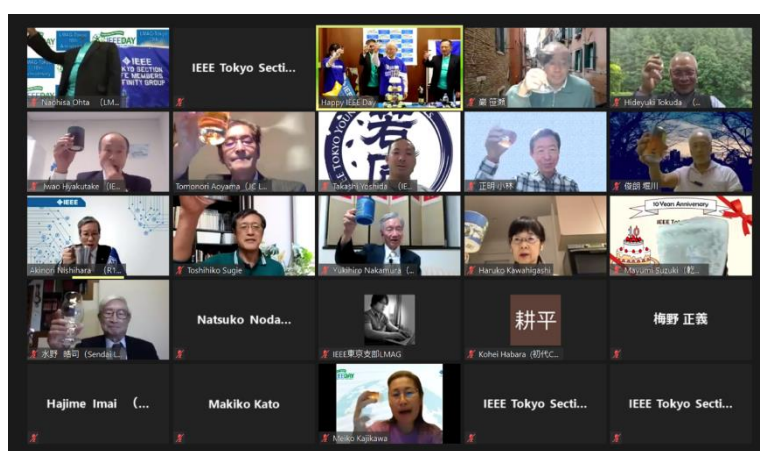

Dr. Habara, LMAG Tokyo's founding Chair, gave a talk entitled "Dawn of LMAG Tokyo" on the initial objectives and activities of LMAG Tokyo including a hidden story. He also mentioned that the origin of "Symposium" in Greek is "Drinking together for a lively conversation". A panel discussion on "What contributions are expected to LMAG" was held inviting 4 panelists moderated by Dr. Ohta, LMAG Tokyo Secretary. The panelists were Dr.

Aoyama, the former R10 LMAG Coordinator; Dr. Yoshida, Tokyo YP Chair; Dr. Noda, JC WIE Chair; and Dr. Nakamura, LMAG Kansai Chair. Each panelist presented suggestions to LMAG activity from her/his own viewpoint after the self-introductions, followed by active discussions among panelists and the audience. Finally, the moderator summarized the panel confirming a common understanding that LMAGs should actively continue efforts on SYWL and inter-LMAG collaborations utilizing life members' rich experiences and should disseminate their activities for another 10 years.

After a short break, the second part of the event was held to celebrate IEEE Day along with the 10<sup>th</sup> Anniversary of LMAG Tokyo and a variety of congratulatory messages were given. The first message was from Mr. Asthana, R10 LMC Chair. Then Mr. Hyakutake, IEEE Japan Office Director, introduced the office and gave a message. Ms. Suzuki, the former Tokyo YP Committee Chair, also delivered a congratulatory message introducing Japanese Sake and the origin of "Kagami Biraki". Dr. Sasase, a former Tokyo Section Chair, gave a congratulatory message introducing useful information about Champagne. LMAG Tokyo officers uncorked a champagne bottle and opened a Sake barrel as a "Kagami Biraki" and Dr. Takano led a toast. Online participants drank a toast depending on their own situations. Dr. Takano cut a memorial cake after blowing 10 candles out for celebrating the 10<sup>th</sup> anniversary of LMAG Tokyo and IEEE Day.

Finally, the event was closed by Dr. Imai. Due to COVID19 pandemic, the event was unusual compared to conventional ones. However, thanks to the strong support of the affinity groups and all IEEE members, especially those who attended till the end, this event ended with a great success.

# IEEE Life Members AG South Australia

## Annual Report 2020

### Don Sinnott, Chair for IEEE Life Members AG South Australia

The IEEE South Australia LMAG holds its meeting in cooperation with the IET Retired Engineers Group, and this year this cooperation has again allowed us to deliver a valuable program of six presentations. The February 2020 meeting was face to face but Covid-19 came to Australia in March. A week before our 1<sup>st</sup> April meeting, it was decided that it was too risky to have a face to face meeting and we decided to have our meeting via Zoom instead. All subsequent meetings have been held in this way. We are very thankful to be able to use the Zoom facilities of the School of Electrical and Electronic Engineering at the University of Adelaide. As a result, the School staff are given a Zoom invitation to the talks as well. Despite or because of Covid19 we have had an increase in attendance at our technical talks.

### Program

Our 2020 program was as follows.

- 5 Feb “BlockChain Technology”, Presenter: Mark Ferraretto, Lecturer in Law at Flinders University (Total attendance 50, including 8 IEEE)
- 1 Apr “Planning your home solar and battery system” Presenter: Dr. Keith Kikkert, Adjunct A/Professor Adelaide University and James Cook University (Total logged on 65, including 11 IEEE)
- 3 Jun “Virtual Voices.” Presenter: Marty Gauvin and Prof Andrew Downing (Total logged on 27, including 3 IEEE)
- 5 Aug “How do machines learn.” Presenter: Dr Zygmunt Szpak, The University of Adelaide (Total logged on 51, including 4 IEEE)
- 14 Oct “Australian Space Initiatives.” Presenter: A/Professor John Culton, Director, Centre for Sustainable Planetary and Space Resources, University of Adelaide (Total logged on 35, including 4 IEEE)
- 4 Nov “Zero carbon long haul aviation: Renewable hydrogen for onboard services and propulsion.” Presenter: Dr. Robert Dickinson, Director Hydricity. The AGM was held in conjunction with this meeting. (Total logged on 37, including 4 IEEE)

### Financial

We are grateful for the Section’s annual rebate that allows us to cover speaker presentation gifts and any costs associated with holding meetings (such as travel or facility costs – none were incurred this year). IEEE does not require LMAGs to provide financial reports. Suffice to say that we have a healthy bank balance that will allow ongoing operation of the Retired Engineers Group/LMAG in 2021 and beyond.

### Office bearers

In 2019 the following were the office bearers.

- Chair: Don Sinnott
- Vice Chair: Cornelis (Keith) Kikkert

At the 4<sup>th</sup> November 2020 AGM, both of these individuals were re-elected for a further one-year term.

## IEEE EDS Malaysia Chapter

### EDS and STEM

#### Maizatul Zolkapli, Chair for IEEE EDS Malaysia Chapter

In conjunction with the IEEE Day 2020 celebration, IEEE EDS Malaysia Chapter, led by Dr. Aliza Aini Md Ralib and Dr. Rosminazuin Ab Rahim, together with Perintis Youth IIUM Chapter organized a STEM online quiz competition on 16<sup>th</sup> October 2020. The quiz, which focused on Nanotechnology, saw close to 50 participants made up of undergraduate students from International Islamic University Malaysia (IIUM). The top three winners were announced and all participants received a certificate.

IEEE EDS Malaysia Chapter also organized an educational and community program for primary schools on 23<sup>rd</sup> September 2020. The event titled “Bringing STEM to life (Amazing Graphite)” was sponsored by IEEE Region 10 EA Fund and IEEE Malaysia Section. The program which was held at Sekolah Kebangsaan Jalan Batu aimed to introduce primary school children to the world of electronics. Two EDS Chapter member with 6 teachers from the school shared their knowledge on STEM using the IEEE EDS-ETC kits.



## IEEE EMBS Malaysia Chapter

### IEEE-EMBS Conference on Biomedical Engineering and Sciences (IECBES2020)

#### Siti Anom Ahmad, Chair-Elect for IEEE EMBS Malaysia Chapter

IEEE EMBS Malaysia Chapter will be organizing its flagship conference, IEEE-EMBS Conference on Biomedical Engineering and Sciences (IECBES 2020) from 1<sup>st</sup> to 3<sup>rd</sup> March 2021. IECBES2020 was initially scheduled on 7<sup>th</sup> – 9<sup>th</sup> December 2020, but due to the Covid-19 pandemic, our 6<sup>th</sup> conference in the series is postponed and will be held fully online. Nevertheless, we will still strive



to offer an uncompromised and equivalent experience in sharing the latest development in biomedical engineering and sciences, and in exchanging ideas and networking among the experts in the field. IECBES2020 will feature distinguished keynote sessions, special sessions on (1) Computing Techniques Applied to Covid-19 Scenarios, (2) Artificial Intelligence in Non-invasive Disease Detection, and (3) Emotion Recognition and Stress Assessment using Physiological Signals, and other technical sessions. For further information, please visit our website <http://iecbes.org> or email us at [info@iecbes.org](mailto:info@iecbes.org).

# IEEE PELS Malaysia Chapter

Dr. Ramani Kannan, Secretary for IEEE PELS Malaysia Chapter

## MATLAB Webinar for Beginner

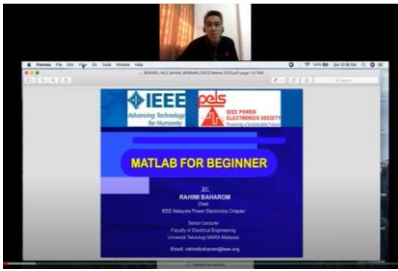

The webinar event was held on 25<sup>th</sup> April 2020 in collaboration with IEEE PES Malaysia Chapter & IEEE UiTM Student Branch. This webinar is free of charge and open to all, especially undergraduate & postgraduate students. It was conducted by Ir. Ts. Dr. Rahimi Baharom, Chair for IEEE PELS Malaysia Chapter from UiTM. The aim of the webinar workshop is to give an overview and exposure of MATLAB software to the undergraduate, postgraduate, and researchers. During the event, participants were given the opportunity to design simple power electronics circuits and application.

## IEEE Senior Membership Elevation Workshop

The IEEE Senior Membership Elevation Workshop was scheduled and conducted on 20<sup>th</sup> June 2020 (2.00 pm – 4.00 pm) via Cisco Webex. Organized by the Power Electronics (PELS) Malaysia Chapter, the speakers are Assoc. Prof. Dr. Shahrin Md Ayob, UTM (Vice Chair for PELS Malaysia Chapter) and Assoc. Prof. Ir. Dr. Tan Chee Wei, UTM (ExComm for PELS Malaysia Chapter). This virtual workshop focused on promoting IEEE members to apply for senior member elevation and serves the society.



## PELS Day Celebration cum NLP

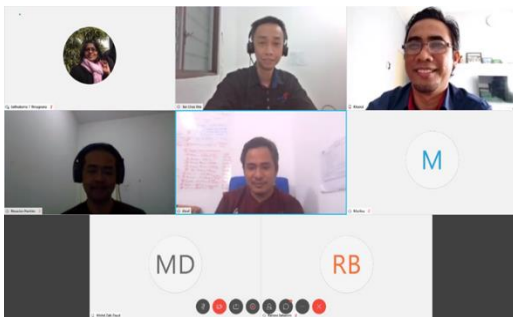

Two signature programs in conjunction with IEEE PELS Day were held on 20<sup>th</sup> June 2020. In the morning session, the National Lecture Program (NLP) featured two speakers: Ts. Dr. Khairul Safuan (UiTM & IEEE PELS Member) and Mr. Arief Noor Rahman (Research Engineer, Yiqun Green Energy Tech, National Taiwan University of Science and Technology). During the events, participants have opportunity to explore the trends on future of power system: converter applications.

# IEEE RAS Malaysia Chapter

Mohamed Khan, Chair for IEEE RAS Malaysia Chapter

## Webinar on Engineering Society and Benefits

A webinar on engineering society and benefits was conducted on 6<sup>th</sup> November 2020 (9.30-11am) at UCSI University, Malaysia. The webinar was delivered by Dr. Mohamed Khan, with 25 participants. IEEE is the world's largest professional society dedicated to advancing technological innovation and excellence for the benefit of humanity. IEEE and its members inspire a global community through IEEE's highly cited publications, conferences, technology standards, and



professional and educational activities. In this talk, students not only gain the complete spectrum of IEEE Societies and the importance of being a professional IEEE member, they were also exposed to the Access essential and exclusive benefits offered to IEEE members, including technical information, networking opportunities, career development, and member discounts.

### Research Colloquium at UCSI Research Center



IEEE RAS Malaysia Chapter organized a research colloquium on 13<sup>th</sup> November 2020, via MS Team. The event started by a welcoming speech by the master of ceremony, during his speech the MC introduced to the audience the main speaker Dr. M. K. A. Ahamed Khan who is currently working as Assistant Professor at UCSI University, Malaysia about his topic of interest on the investigation of gait and biomechanical motion for developing energy harvesting system. More than 25 participants involved. A working prototype has been modeled and devised based on the findings from the research. The prototype has been made from 3D printing, and a combination of piezoelectric materials, then tested and the results were explained. The event

ended at 4PM by a closing speech by the MC. The information gained by the participants during this talk will play a part during their professional career development. The MC thanked all the participants and the speaker for their participation and commitment.

## IEEE SPS Bombay Chapter

### Regional SPS Congress 2020

#### Satyanarayana Bheesette, Chair for IEEE SPS Bombay Chapter

Virtual Regional Signal Processing Society (SPS) Congress 2020 was organized by the IEEE SPS Bombay Chapter on 28<sup>th</sup> November 2020. The Congress was attended by more than 100 participants from among the twelve SPS chapters from India and one from Bangladesh. Dr. Satyanarayana Bheesette [1] welcomed the participants and Prof. Suryanarayana Doolla [2] made opening remarks.



Prof. K.V.S. Hari [3] and Ken Ma [4] briefed on SPS in R10 and its initiatives. Profs. Ken Ma and Ami Wisel [5] delivered distinguished lectures, before joining the panel discussion along with Profs. Yashwant Gupta [6] and Anubha Gupta [7]. A virtual social interaction was organized using the “Run The World” App. A Women in Signal Processing Session was conducted by Prof. Celia Shahnaz [8], followed by a session on Education and Outreach by Profs. Angshul Majumdar [9] and Chirag Paunwala [10]. The Congress was concluded with brainstorming on future collaborative events between the Regional Chapters, in which all the Chapter Chairs participated.



## IEEE MTT/AP/EMC Islamabad Joint Chapter

### Webinar Series Update and Chapter Expansion

**Noshewan Shoaib, Chair for IEEE MTT/AP/EMC Islamabad Joint Chapter**



The webinar series, initiated by IEEE MTT/AP/EMC Islamabad Joint Chapter at the Research Institute for Microwave and Millimeter-Wave Studies (RIMMS), National University of Sciences and Technology (NUST), Islamabad, Pakistan, has been a successful journey with an aim to promote the knowledge sharing during COVID-19 pandemic. The chapter has conducted more than 20 webinars

so far. The speakers include renewed researchers and distinguished lecturers of MTT, AP and EMC societies. In particular, the chapter has conducted a technical webinar titled “Innovative Applications in Health and Food Industry through 3-D Microwave Sensing and Imaging” on 6<sup>th</sup> October 2020 to celebrate the IEEE Day. The speaker was Prof. Francesca Vipiana from Dept. of Electronics and Telecommunications, Politecnico di Torino, Italy. To amplify the nature of technical activities, the chapter has been expanded to include IEEE Circuits and Systems Society (CAS) in October 2020.

## IEEE PELS/IES Bombay Joint Chapter

### 1<sup>st</sup> IEEE International Conference STPEC 2020 Organized Virtually

**Pradyumn Chaturvedi, Chair for IEEE PELS/IES Bombay Joint Chapter**

The 1<sup>st</sup> IEEE International Conference on Smart Technologies for Power, Energy and Control (STPEC2020) was hosted by the Department of Electrical Engineering, VNIT, Nagpur, India during 25<sup>th</sup> and 26<sup>th</sup> September 2020. This conference was financially sponsored by the IEEE Industry Applications Society and technically sponsored by the IEEE Power Electronics Society; jointly organized by IEEE PELS-IES Bombay Joint Chapter and EED, VNIT Nagpur. Total number of papers received, accepted & presented were 324, 152 & 141 respectively from 9 countries. Six keynote talks were delivered by Jih-Sheng Lai, Mangesh Borage, Sushil Soonee, Subhashish Bhattacharya, Alberto Borghetti and Frede Blaabjerg. Prof. Georges Zisis, President of IEEE IAS, informed that 20% of the papers from STPEC2020 are eligible for consideration in IEEE Transaction on Industry Applications. General Chairs for the conference were Jih-Sheng Lai, Akshay Rathore, Hiralal Suryawanshi and Mohan Aware; General Co-Chairs were Suryanarayana Doolla, Arvind Kumar, Vijay Borghate, and Madhuri Chaudhari; and Organizing Secretaries were Pradyumn Chaturvedi and Arghya Mitra.





# STUDENT BRANCH AND STUDENT CHAPTER ACTIVITIES



## 8. STUDENT BRANCH AND STUDENT CHAPTER ACTIVITIES

### IEEE AIUB Student Branch [Bangladesh Section]

#### Distinguished Lecture Session on “Epilepsy, Algorithms, and AI: Personalized Seizure Forecasting”

**Fardeen Mahbub, Secretary for IEEE AIUB EMBS Student Chapter**



On 5<sup>th</sup> November 2020, the IEEE AIUB Student Branch in collaboration with the IEEE EMBS AIUB Student Chapter organized a Distinguished Lecture session titled “Epilepsy, Algorithms, and AI: Personalized Seizure Forecasting” via the virtual platform of GOOGLE MEET. The session was conducted by IEEE EMBS Distinguished Lecturer, Prof. David B. Grayden, Clifford Chair, Neural

Engineering; Director, MSE Medical Technologies Research Platform, Department of Biomedical Engineering, University of Melbourne. In his talk, he focused on the disorder epilepsy including its significant impacts of AI-based computational studies, and emphasized various ways for providing an automated and standardized protocol for supporting clinical decisions with the intellect & proficiency of the engineers. The session witnessed more than 195 participants from different parts of the world, including numerous renowned researchers in the Biomedical Engineering sector, along with the remarks from Dr. Celia Shanaaz, Chair for IEEE Bangladesh Section, and Dr. Sheikh Anowarul Fattah, Chair for IEEE EMBS Bangladesh Chapter.

#### Webinar Session on ‘Application of Wireless Sensor Network (WSN) in Precision Agriculture: Issues and Challenges’

**Fardeen Mahbub, Publication Coordinator for IEEE AIUB Student Branch**

On 9<sup>th</sup> October 2020, the IEEE AIUB Student Branch in collaboration with the IEEE Computer Society AIUB Student Chapter successfully organized a webinar session titled “Application of Wireless Sensor Networks (WSN) in Precision Agriculture: Issues and Challenges” through the CISCO WEBEX Meeting platform. The session was conducted by IEEE Computer Society Distinguished Speaker, Mohamed Rawidean Mohd Kassim, who is also R10 Regional Coordinator for IEEE Computer Society, and R&D Manager at Technology Deployment Department, Malaysian Institute of Microelectronic Systems, Ministry of Science, Technology and Innovation Malaysia. The session focused on the elaborate ideas on Wireless Sensor Networks in the field of precision agriculture and also explained how WSN, AI, Big Data, robotics, drones, machine vision, and cognitive technologies could play their respective roles in this field considering the world food demand in future. The session ended up with an interactive Q/A session and witnessed the participation of a total of 93 participants.



## IEEE UCET IUB Student Branch [Bahawalpur Subsection]

### Biomedical Robotics for Sustainable Future

Dr. Khan Bahadar Khan, Advisor for IEEE UCET IUB EMBS Student Chapter

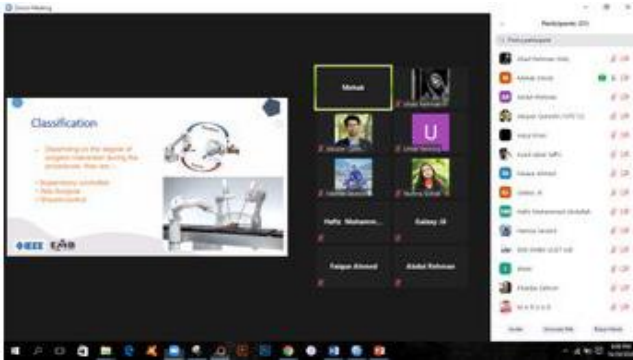

IEEE UCET IUB EMBS Student Chapter organized a virtual session on the topic of "Biomedical Robotics for sustainable future" on 29<sup>th</sup> October 2020, with 21 participants. The speaker Mehak Azeem explained "Biomedical Robotics" and the role of robots in different medical fields and how these robots can revolutionize the future of the medical field. She discussed their importance in this pandemic as we implemented robotic machines to

take care of Corona patients. Further, she made the audience aware of the different types of medical robots which help the doctors to diagnose the disease. Moreover, she explained the different medical robots and their applications, such as companion robots that help patients who need a regular check-up, and prostheses which can replace damaged human organs. She also discusses Obi robots that can help disabled person in which she is currently working. The talk ended with a question and answer session.



# OTHER ARTICLES



## 9. OTHER ARTICLES

### IEEE INMIC 2020

Prepared by: Khan Bahadar Khan, General Secretary for IEEE Bahawalpur Subsection



The 23<sup>rd</sup> IEEE International Multitopic Conference (INMIC 2020) was held at the Islamia University of Bahawalpur (IUB), Pakistan from 5<sup>th</sup> to 7<sup>th</sup> November 2020, sponsored by IEEE Bahawalpur Subsection and IEEE ComSoc Lahore Section, and in collaboration with IEEE Lahore Section. INMIC 2020 is the flagship annual conference of IEEE Pakistan mainly focused on multidisciplinary topics in the field of electrical & electronics engineering, computer systems

engineering, computer science, and other related fields. We received an overwhelming response with around 450 submissions from industries, academia, and research institutions on twelve tracks. 165 papers were accepted (acceptance rate of 40%) for oral presentations and inclusion in conference proceedings.

Day 1 of the conference started with the opening ceremony at the Main Auditorium, IUB. On behalf of the Organizing Committee, Patron for INMIC Prof. M. Amjad and Conference Chair Dr. M. Ali Qureshi expressed sincere gratitude to the distinguished keynote speakers, guests, conference participants, peer-reviewers, as well as to the authors. Prof. Zainal Bin Salam, distinguished keynote speaker from Centre of Electrical Energy Systems, Universiti Teknologi Malaysia delivered his talk on *“Building the Solar Photovoltaic Systems Industry Ecosystem”*. Prof. M. Ali Imran, Dean of University of Glasgow, UESTC, UK delivered a talk on *“Overcoming digital divide by connecting the unconnected – technology enablers and future overview”*. Day 1 also featured four virtual parallel sessions on Renewable Energy, Image Processing, Intelligent Systems & Applications, and Machine Learning.

Day 2 of the conference started with four virtual parallel sessions on Power Systems, Smart Systems, Biomedical Image Processing, and Information & Software Technologies. Prof. Anouar Belahcen, Aalto University, Finland then enlightened the audience on *“Numerical Analysis of Synchronous Machines by Coupled Circuit and Static Field Equations”*. Prof. Azeddine Beghdadi, University Paris 13, France delivered his keynote talk on *“Image Quality in the Context of Medical Imaging and Diagnosis”*.

The last day of the conference started with four virtual parallel sessions on Signal Processing, Control Systems, Antenna & Microwave Communications, and Internet of Things. In the closing ceremony Conference Chair Dr. M. Ali Qureshi, Patron Prof. M. Amjad, and Patron-in-Chief and Vice-Chancellor IUB Prof. Athar Mehboob presented their closing remarks and thanked all dignitaries, authors, keynote speakers, participants, and volunteers. The conference was concluded with award distribution and a group photo.

# IEEE ICCA 2020

Prepared by: Rabindra Nath Shaw, Chair for IEEE ICCA 2020 Conference

The 2020 5<sup>th</sup> IEEE International Conference on Computing, Communication and Automation (ICCCA 2020) was jointly organized by Aurel Vlaicu University of Arad, Romania & Galgotias University, India on 30<sup>th</sup> and 31<sup>st</sup> October 2020. ICCCA 2020 has emerged as a premier conference to bring researchers, scientists, and industry professionals to discuss novel ideas in the field of computing, power, and communication. This year, the conference was joined by researchers, students, and industry professionals from five countries. Due to the Covid-19 pandemic, the conference was organized online.

In the inaugural session of ICCCA 2020, opening remarks were given by Prof. Ramona Lile Rector, Aurel Vlaicu University of Arad, Romania and welcome address were given by Prof. Preeti Bajaj & Prof. R V Babu, Galgotias University, India.

The guests of honour of the conference were Prof. Mohammad S. Obaidat, IEEE Life Fellow; Dr Tomy Sebastian, IEEE Fellow; Prof. Saifur Rahman, IEEE Fellow; Prof. Vincenzo Piuri, IEEE Fellow; Prof. Bhim Singh, IEEE Fellow; Prof. Jim Conrad, President of IEEE USA; Prof. Georges Zissis, President of IEEE IAS, USA; Prof. Saad Mekhilef, Technical Chair for IEEE ICCA 2020; Prof. Valentina E Balas, Liaisons for IEEE ICCCA 2020 and Prof. Monica Bianchini, University of Siena, Siena, Italy. The vote of thanks was given by Conference Secretary.



The conference commenced with a keynote speech on “Developments in Vehicle Electrification” by Dr. Tomy Sebastian, IEEE Fellow. This was followed by concurrent paper presentation panels FD1 to FD6 in 2 technical sessions wherein 74 papers were presented with the participation of 76 authors. After the first three technical sessions a keynote speech on “New Biometric Schemes for Risk-Based Authentication in Web Environment” was given by Professor Mohammad S. Obaidat, IEEE Life Fellow. Thereafter, the remaining technical session FD4 to FD6 for the first day commenced. After this, there were two keynote speeches which were attended by a large number of participants. The first keynote speech was given by Prof. James M. Conrad of Department of Electrical and Computing Engineering, University of North Carolina Charlotte, North Carolina, USA on “IEEE MOVE disaster

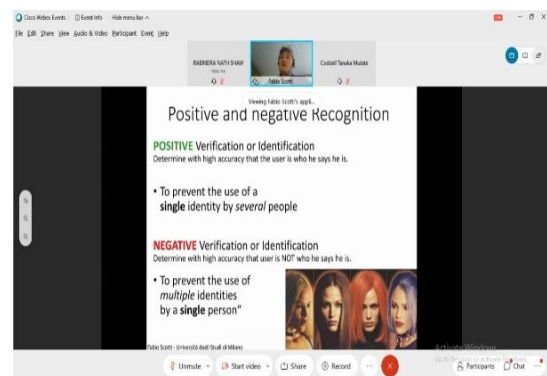
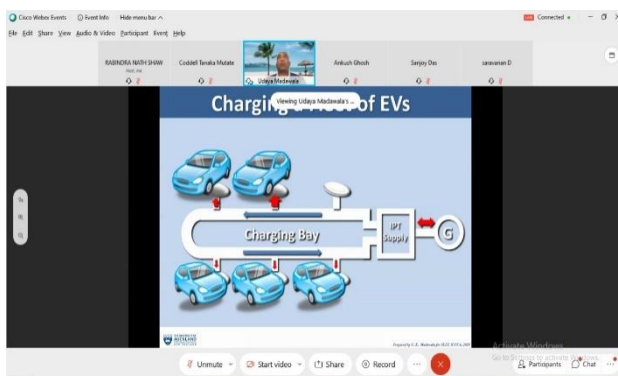

relief project, vehicle, and technology”. The second keynote speech was given by Prof. Mariesa L. Crow, IEEE Fellow on “The IEEE Fellow Nomination Process – Best Practices for Success”.

The second and final day started with two keynote speeches. The first one was given by Professor Udaya K. Madawala, Department of Electrical & Computer Engineering, The University of Auckland New Zealand on “V2X Technologies: Wired or Wireless?”. The second keynote speech was given by Prof. Rajkumar Buyya IEEE Fellow and Director of Cloud Computing and Distributed Systems (CLOUDS) Lab on “Neoteric Frontiers in Cloud and Edge Computing”. Then, technical sessions SD1-SD6 for the second day started in which 72 papers were presented and attended by 74 authors. The last keynote speech of the conference was given by Prof. Fabio Scotti, Università degli Studi di Milano on “Artificial Intelligence for Biometric Systems: Applications in Cyber Security and Ambient Intelligence” which was attended by a large number of students and researchers.

ICCCA 2020 concluded with a closing session which was addressed by Prof. Fabio Scotti, Università degli Studi di Milano. The conference report was given by Dr. Nishad Mendis, Technical Chair for IEEE ICCCA 2020. Vote of thanks was given by Conference Secretary and with this, the ICCCA 2020 concluded.

## IEEE PES Women in Power Congress in Region 10

Prepared by: Dr. Celia Shahnaz, Chair for IEEE Bangladesh Section

IEEE PES Women in Power Congress in Region 10 was organized by WIE Affinity Group Bangladesh Section, IEEE Bangladesh Section and IEEE PES Women in Power on 12<sup>th</sup> & 13<sup>th</sup> September 2020 from 4PM to 8PM (GMT+6). A world bank initiative WePower was the partner of the event. It was a digital event where 184 participants from 28 different countries of 6 continents, namely USA, Japan, Singapore, China, India, Australia, Indonesia, Sri Lanka, Malaysia, New Zealand, Pakistan, Peru, Bhutan, Brazil, Colombia, Taiwan, South Korea, Afghanistan, Nepal, France, Kenya, Nigeria, UK, Bolivia, Panama, Mongolia, Hong Kong and Bangladesh participated. The event started with the program vision shared by Dr. Celia Shahnaz, Chair for IEEE Bangladesh Section and General Chair for IEEE PES Women in Power Congress in Region 10. She is also the lead of two strategic partners of WePower, namely, IEEE PES Women in Power and IEEE Bangladesh Section.

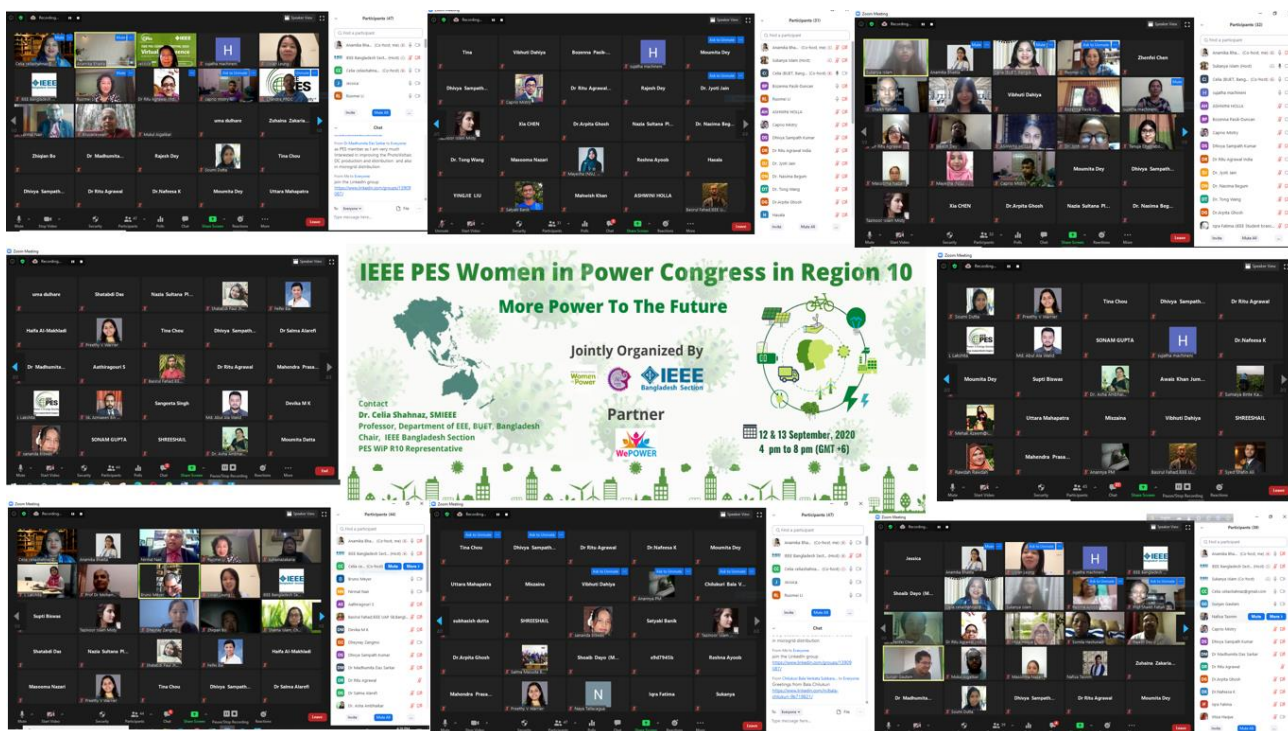



The chief guest of the event was Dr. Jessica Bian, Vice President of Grid Services, Grid-X Partners and IEEE PES President-Elect (2020-2021). The special guests were Dr. Roumei Li, Chair for IEEE PES and Women in Power (WIP), and Dr. S N Singh, Vice Chair for R10 Technical Activities and Chair for IEEE India Council.

The speakers for Day 1 were Dr. Bruno Meyer, Vivian Sin Yee Leung, Dr. Shama Naz Islam, Dr. Zhenfei Chen, Dr. Nirmal-Kumar C. Nair, Lakshita, Dr. G. Bhuvaneshwari, Dr. Zhiqian Bo, Dr. Yu Juan and Dr. Chandrasekhar Reddy Atla. While the speakers for Day 2 were Dr. Feifei Bai, Dr. Alan Harvey, Xia Chen, Prof. Sunitha Beevi. K, Dr. Tong Wang, Jinghan He, Yingjie Liu, Gunjan Gautam, Dr. Tina Chou and Dr. Zhenfei Chen.

Prof. Dr. Shaikh Anowarul Fattah, IEEE PES E-News Update Editor shared briefly how PES e-News update can be utilized as a platform to recognize all contributors at the end on both days. Prof. Dr. Bozena Pasik-Duncan, lead of strategic partner IEEE WIE of WePower provided closing remarks. Anamika Bhakta, Nafisa Tasnim, Irtiza Haque, Shaila Sharmin, Jannatul Adan, Sukanya Islam, Joyeta, Sk. Azmaeen Bin Amir, and Raihan Ur Rashid was part of the amazing volunteer team.

For details, please take a look at the below links:

Facebook link: <https://web.facebook.com/events/1021293628312283?rdc=1&rdc=1>

Linkedin link: <https://www.linkedin.com/groups/13909087/>

Event Video Link: Day 1: <https://youtu.be/5Xhi1fjBINI>

Day 2: <https://youtu.be/Cdc7IC7LJl8>

Biography Link of Speakers:

<https://drive.google.com/drive/folders/1Bx0qTcnsEB8asMUK030OYCN2zV5Fd-Za?usp=sharing>

## Women of Wisdom (WOW) Webinar Series

**Prepared by: SunithaBeevi.K, WiP Coordinator for IEEE Kerala Section**

Women of Wisdom (WOW) is an International Tech-Talk Webinar Series jointly organized by IEEE PES WiP Kerala Section and IEEE WIE Kerala Section, in association with IEEE R10 PES WiP and hosted by IEEE TKM College of Engineering, Kollam Student Branch. The objective of this program is to open an international gateway for the audience to interact with eminent women leaders from different parts of the world and discuss about the rapidly emerging technologies. We are aiming to encourage interdisciplinary researches in cutting edge technologies, to encourage research collaboration, to empower women to take a leadership position and to enhance the POWER of women through POWERFUL WOMEN TALKS.



The WOW Tech Talk Series was inaugurated on 25<sup>th</sup> June 2020 by Dr. Celia Shahnaz, R10 WiP coordinator and has hence been enlivened with vibrant and charismatic women who joined the forum to discuss the rapidly emerging technologies. We have conducted 10 such sessions with esteemed women speakers from different countries of R10 in the year 2020. The world has witnessed several successful women who seized every opportunity to prove that if a woman is educated, the entire generation is educated, and Kerala WiP opened an international gateway for them. The event was open to all professionals and students including IEEE members.

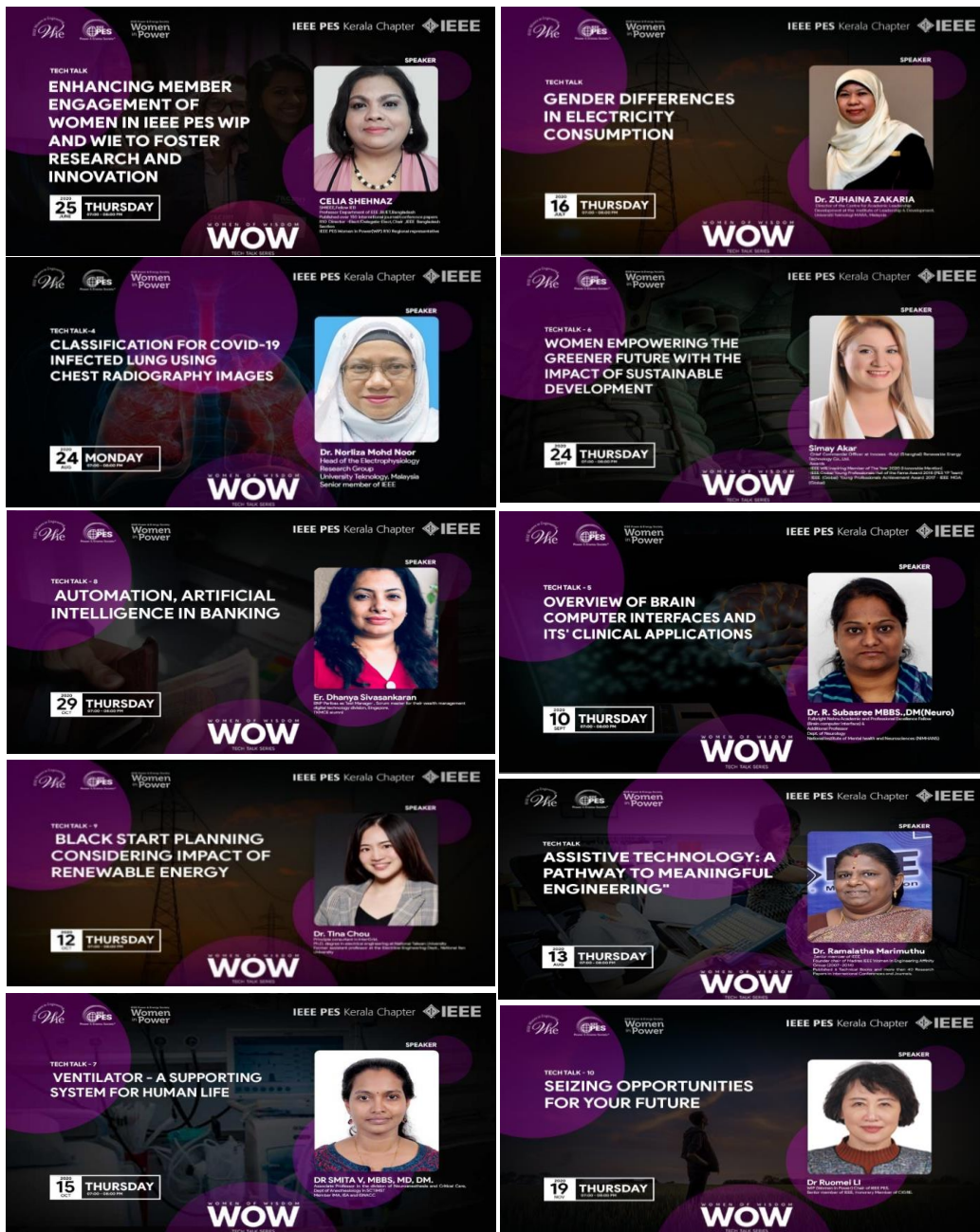

## Virtual POCO 2020

Prepared by: Nordin Ramli, Executive Committee for IEEE Malaysia Section

Despite the Covid-19 pandemic, 2020 IEEE R10 Panel of Conference Organizers (POCO 2020) was successfully organized by IEEE Malaysia Section and broadcasted virtually on 30<sup>th</sup> November 2020, 9AM – 2PM Malaysia Time. POCO is an annual event for leading conference organizers around the world. IEEE organizes this event to share resources and ideas with all scientific associations and non-profit



conference organizers. POCO provides a platform for thought leaders and decision-makers to share conference leadership practices, discuss challenges in the conference landscape, envision the future, and launch new conference initiatives. This event provides an opportunity to conference organizers to network and share ideas with the whole community. POCO 2020 in Kuala Lumpur was organized for the second time after the first successful event held in

2017. This POCO 2020 event was supported by IEEE Region 10 Support Grant. The event was joined by more than 100 participants from various places across Asia.

The organizing committee of POCO 2020 showcased renowned speakers from Region 10 as well as from Malaysia. The event started with the officiating remarks by the Director of IEEE Region 10, Prof. Akinori Nishihara. He emphasized on the importance of preserving quality in conference management, which was also an important element to be reviewed by the Region 10 office. The keynote address was delivered by Prof. Lance Fung, the 2021-2022 R10 Director-Elect, where he again emphasized on quality control in the process of reviewing conference papers. Other speakers included Prof. Zuhaina Zakaria, Prof. Celia Shannaz, Dr. Nirmal Nair, Dr. Mohamad Faizal Ahmad Fauzi, Dr. Fawnizu Azmadi Hussein and Dr. Md Pauzi Abdullah. Mr. Deepak Mathur, IEEE R10 2021-2020 Director spoke of his vision and plan for year 2021, and shared his idea on enhancing collaboration.

POCO 2020 was also fortunate to have the CEO of Malaysia Convention & Exhibition Bureau (MyCEB), who shared their initiatives and support grants for conferences by the government. IEEE Malaysia Section is hoping this event can provide the platform to utilize the support initiatives by the Malaysian government that conference organizers can benefit from. At the end of the event, a panel session was held to share the experiences of running virtual conferences in the midst of the pandemic. The panelists include Prof. Supavadee Aramvith (Vice-Chair, IEEE SYWL 2020), and Mr. Muhammad Faris Mohd Firdaus & Mr. Muhammad Hisyam Harmizon, from UTHM Student Branch who had organized IEEE SCORED 2020.



POCO2020 event was successfully organized and benefitted many participants throughout the Asia-Pacific region. A similar event is planned in the future to continue the sharing of best practices on conference management to potential conference organizers within IEEE Region 10.



# Quarter Tech Talk Table 1.0

Prepared by: Ramneek Kalra, IEEE Impact Creator and YP & Shailesh Prabhu, IEEE YP



A group of IEEE Young Professionals & Impact Creators gathered on 29<sup>th</sup> November 2020 (10:00AM - 11:30AM IST) to create awareness on technology and form a collaborative environment by initiating “**Quarter Tech Talk Table 1.0 (QT3)**” in the form of a panel discussion on the topic - “**Technology for Public Safety**”.

**Motivation:** To create a broad collaborative group of Young Professionals and Impact Creators to share some insights on cutting-edge technologies to all technology enthusiasts by having a panel discussion. The primary motivation of QT3 comes from the IEEE Strategic Plan 2020-2025 which inspires us to conduct this event with no boundaries. This provides opportunities to volunteers who collaborated to make this event a grand success.

**Objectives:** The objectives of QT3 are as stated below:

- Creating a broad collaboration for sharing knowledge of Industrial Technologies.
- Creating a bridge to connect IEEE Young Professionals through this activity for career and professional development.
- Sharing opportunities for elevating ideas using research-based oriented learning.
- Creating an open forum for discussion on recent technological advancements and challenges.

### Event Details:

In the 1<sup>st</sup> Edition of QT3, prominent IEEE Young Professionals and Impact Creators across the globe came together for a panel discussion as listed below:

- Aakash Bansal (PhD Researcher at Loughborough University, UK)
- Shailesh Prabhu (Senior 5G Developer at Wipro Limited, India)
- Ramneek Kalra (Project Engineer at Wipro Limited, India)
- Bhagya Samarakoon (AdCom Member, IEEE WIE Singapore Section, Singapore)
- Kirthika Senthil Kumar (AdCom Member, IEEE WIE Singapore Section, Singapore)
- Pia Torres (RoboTeam Founder & Director, IEEE HAC Member, Argentina)

**IEEE** **Quarter Tech Talk Table 1.0**  
presenting a Panel Discussion on:  
"Technology for Public Safety"  
(29th Nov 2020 10:00 AM - 11:30 AM IST)  
**Panelists**

**Aakash Bansal**  
PhD Researcher,  
Loughborough University  
United Kingdom (UK)

**Bhagya Samarakoon**  
IEEE WIE Singapore Section,  
AdCom Member  
Singapore

**Shailesh Prabhu**  
Senior 5G Developer  
Wipro Limited, India

**Pia Torres**  
Roboteam Founder & Director  
IEEE Humanitarian Activities  
Committee Member  
Argentina

**Ramneek Kalra**  
Project Engineer | IEEE Impact Creator  
Wipro Limited, India

**Kirthika Senthil Kumar**  
AdCom Member  
IEEE WIE, Singapore

**General Chair**

**Moderators**

**Register Below:**

**Dr. Prashant R. Neir**  
Associate Professor, Amrita Vishwa  
Vidyapeetham, Coimbatore,  
Tamil Nadu, India

**Wathmini Sharika**  
Production Engineer,  
Central Industries PLC, Sri Lanka

**Naveendra Jayakody**  
Electrical Engineer,  
Sunleaf Solar Solutions, Sri Lanka

**Moderators:**

- Wathmini Sharika (Production Engineer, Central Industries PLC, Sri Lanka)
- Naveendra Jayakody (Electrical Engineer, Sunleaf Solar Solutions, Sri Lanka)

**General Chair:**

- Dr. Prashant R. Nair (Associate Professor, Amrita Vishwa Vidyapeetham, Coimbatore, Tamil Nadu, India)

**Points of Discussion**

Some of the key takeaways from this 1<sup>st</sup> Edition of QT3 are as listed below:

- Eliminating misconceptions in cutting-edge technologies for public safety including 5G, robotics and edge computing.
- Since the panel discussion was conducted on 25<sup>th</sup> November 2020 which is also the International Day of Elimination of Women Violence, the panelists pointed out how technology can be used to eliminate women violence from public places and insecure areas. In the same regard, the panelists also highlighted critical parameters enabled by technology including *Reliability, Affordability, Latency and Feasibility*.

**Round 1 (Open Discussion on Technology for Public Safety):**

- One of the panelists highlighted about the application of Robotics during this pandemic situation and how it has been used to enable public safety by means of examples like hospital spray robots, shopping mall security robots, elevator cleaning robots etc. Adding to that, having cleanliness robots and robots for social distancing monitoring in public places were among others.
- From the healthcare industry perspective, one of the panelists highlighted two key factors which is applying robotics and making lives better. One of these was having robotics in the swabbing process of patients for COVID19 which can be automated thereby reducing human interaction.
- From the edge computing perspective, one of the panelists put pointers ahead, explaining what can be achieved if integration of 5G and IoT is done. Adding to that, edge computing can provide the base framework, which industries are using and implementing in their “Back to Office” infrastructure to have full monitoring ability on the employees’ activity within the premises.

**Round 2 (Panel Q&A Discussion):**

- With 5G using high frequency radiations, one of the panelists highlighted that this is because of the increase in the number of devices we are using these days, which he mentioned is directly proportional to the bandwidth i.e. the more the devices, the more bandwidth is required to serve the users. This increases the capacity of the network and thereby fulfils connectivity demands. He also highlighted about the researches going around along with the expectations from 6G frequency bands in numerous academic universities and industries. Putting the misconceptions held by a lot of people about 5G, panelist shared the example of his own experiment of feeling the radiation between a smart phone and an antenna with a microwave oven to shut the point of “5G causes cancer”. Evidently, oven causes more danger than our own smart phone.
- Adding to above points, another panelist pointed out one of the common parameters in the adoption of any technology by the telecommunication units is the compliance to Specific Absorption Rate (SAR), which is being approved by ITU. Adding to that, he highlighted that 5G is not an exception to this and will be safe for users giving a proper and safe way of communication. He added the applications of 5G in mission-critical services including emergency recovery, remote surgery and *Push to Talk*. He also pointed out how 1/10<sup>th</sup> reduction of latency in 5G compared to the existing 4G network can disrupt industry verticals and enable critical operations. Self-driven car is one of the classical examples to highlight latency as a prime factor for responding to emergency situations and thereby endorsed 5G as a technology for future.

- Highlighting on the popular question “*Will Robots be taking jobs of Humans in coming years?*” - One of the panelists in robotics domain pointed out her personal experience of having this question asked from one of the immigration officers from one country, where she had visited for a robotics conference. She highlighted the possibilities of having more high-skilled jobs in robotics organizations. Also, she added that the jobs will be taken up by robots where humans cannot achieve the outcome, or where minor jobs including floor cleaning/maintenance etc. can be automated. In an optimistic way, she added that it will be a win-win situation for both robots & humans if humans can be trained well to work for these high-skilled jobs for working in robotics companies.
- Coming to the healthcare industry and how robotics can work on the reliability and trust value among doctors, one of the researchers from the panel pointed it rightly by mentioning it is not the robots who took the action often in healthcare, but it depends upon the doctor whether to trust that action or not. She added that it is all about training the control system of robot to act accordingly in the repetitive and smart way. She mentioned that robots cannot replace the doctors’ experience of using the tools and how much pressure needs to apply on tissues while in open surgery. Putting those statements in the robotics trust value, she mentioned the recent transition of having research on Real-Time Feedback for Surgery purposes done by robots to get the confidence back to doctors. With that, she concluded that “*ultimate decision maker will always be humans*”. Robots are intended to assist the critical operations and make life easy.
- At the end of Round 2, another panelist highlighted how IoT and edge computing can help in turning up the possibilities of having schools/industries open again after this pandemic situation. He started with sharing his own experience of his organization by having Android application and IoT sensors deployed over numerous spots including entrance gate, lift panel, breakout rooms near coffee machine etc. He added that in the upcoming days, the transition of using smart devices for smart monitoring of campus by not touching objects around them is going to help against infections.

**Round 3 (During a natural calamity or a crisis, most of the technology seems to be of no use. How does technology assist in such scenarios?):**

- Altogether every panelist put their own technology aspect how their own domain can put a proactive approach to natural calamity by highlighting some of the prime factors including prediction using AI and ML, deployment of smart sensors around cities/countries borders, application of robotics in rescuing people from emergency locations etc. With that, adding to economic feasibility and having Technology Acceptance Ratio (TAR) to be counted on priority always comes with trade-off. This trade-off of not accepting technology can be eliminated by having smart machines deployed with very less amount of latency which will give outcome in very demanding way.

**“Ask the Panelist”:** Under this last section of this Tech Talk, virtual floor was open for asking queries on the basis of discussion to the entire panelists, under which one of the attendees asked “*How the deployment of technologies like 5G and others can be accurately compared to the theoretical promises, especially in rural area?*” In response, the panel mentioned that it will considerably take much time ahead to implement at that level, but lot of telecommunication companies are already in process of pushing the bars up. This enhancement in frontline will surely help us to accept the technology in a very accurate way and especially in the rural part of any nation across the planet.

With the ending of this QT3 1.0, the General Chair put together the thank remarks and shared the next QT3 2.0 date, which is tentative 7<sup>th</sup> February 2021. Registrations are already open for the QT3 at: <https://forms.gle/x2ost6UqqBGiqtxJ6>



# AWARDS AND FUNDING



## 10. AWARDS AND FUNDING

### IEEE Fellows Elevated as of January 2021 - Region 10

Australian Capital Territory Section	
<b>Xiuping Jia</b>	for contributions to feature mining and classification of hyperspectral images
Beijing Section	
<b>Hongke Zhang</b>	for contributions to high-speed railway communications
<b>Hua Geng</b>	for contributions to control of renewable energy power converters
<b>Huadong Ma</b>	for contributions to multimedia sensor networks
<b>I Chih-lin</b>	for leadership in wireless mobile networks
<b>Jie Tang</b>	for contributions to knowledge discovery from data and social network mining
<b>Junzhi Yu</b>	for contributions to bio-inspired swimming robots
<b>Lintao Zhang</b>	for contributions to computer-aided verification with efficient Boolean satisfiability solvers
<b>Shixia Liu</b>	for contributions to visual text analysis and visual model analysis
<b>Wenchuan Wu</b>	for contributions to energy management, operations, and control
<b>Xiaofeng Liao</b>	for contributions to neurodynamic systems and chaotic cryptography
<b>Yu Zheng</b>	for contributions to spatio-temporal data mining and urban computing
<b>Zhao-liang Li</b>	for contributions to thermal infrared remote sensing
<b>Zhaocheng Wang</b>	for contributions to pilot design and modulation of OFDM wireless systems
Chengdu Section	
<b>Chunming Li</b>	for contributions to computer vision and medical image analysis
Delhi Section	
<b>Richa Singh</b>	for contributions to robust and secure biometrics
Fukuoka Section	
<b>Gourab Majumdar</b>	for contribution to power semiconductor devices and intelligent power module
Guangzhou Section	
<b>Jizhong Zhu</b>	for application of optimization methods for real-time economic power system operation
<b>Jun Li</b>	for contributions in hyperspectral image processing
Hefei Subsection	
<b>Houqiang Li</b>	for contributions to video coding and multimedia content analysis
<b>Meng Wang</b>	for contributions to multimedia content analysis and retrieval
Hong Kong Section	
<b>Cong Wang</b>	for contributions to security of cloud storage and computation
<b>Francis Lau</b>	for contributions to analysis of chaotic comm. systems and low-density parity-check code design
<b>Kaibin Huang</b>	for contributions to wirelessly powered communications and multi-antenna communications
<b>Matthew Mckay</b>	for contributions to random matrix theory in statistical signal processing
<b>Pascal Vontobel</b>	for contributions to graphical models for channel coding
Kansai Section	
<b>Jun Ohta</b>	for contributions to CMOS image sensors and devices for biomedical applications
<b>Shinzo Tamai</b>	for contributions to control for motor drives and three-level converters
<b>Tomohiro Nakatani</b>	for contributions to far-field signal processing for speech enhancement and recognition
Nagoya Section	
<b>Jianqing Wang</b>	for contributions to electro-magnetic compatibility of biological and wearable/implant devices
Nagpur Subsection	
<b>Hiralal Suryawanshi</b>	for contributions to converters for renewable energy systems, drives, and electrical machines



Nanjing Section	
<b>Dong Yue</b>	for contributions to network-based control and its applications to power systems
<b>Geyi Wen</b>	for contributions to antenna quality factor
<b>Hanchuan Peng</b>	for contributions to visualization and quantitative analysis of large-scale biological data
New South Wales Section	
<b>Alberto Avolio</b>	for contributions to knowledge and monitoring of arterial hemodynamics
<b>Shujun Zhang</b>	for contributions to the development of advanced piezoelectrics for transducers
<b>Willy Susilo</b>	for contributions to cloud computing security
<b>Wing Kwan Ng</b>	for contributions to resource allocation for wireless communication networks
Queensland Section	
<b>Daniel Quevedo</b>	for contributions to optimal and model predictive control
<b>Firuz Zare</b>	for contribution to power converters and leadership role in standardization
Sendai Section	
<b>Tetsuya Suemitsu</b>	for contributions to high-frequency high-electron-mobility transistors
Seoul Section	
<b>Byoung-hoon Kim</b>	for contributions to development and standardization of mobile communication technologies
<b>Chan-byoung Chae</b>	for contributions to MIMO design and prototypes for emerging communication systems
<b>Hyundong Shin</b>	for contributions to the analysis and design of wireless communication and networking
<b>Kyoung Mu Lee</b>	for contributions to image restoration and visual tracking
<b>Wonjun Lee</b>	for contributions to multiple access and resource allocation in wireless networks
Shanghai Section	
<b>Bao-liang Lu</b>	for contributions to artificial neural networks and affective brain-computer interfaces
<b>Daoqiang Lu</b>	for development of materials and manufacturing processes for mobile devices
<b>Huang De Shuang</b>	for contributions to neural networks for pattern recognition and bioinformatics
<b>Jingyi Yu</b>	for contributions to theor. analysis, algorithms and systems for comp. photog. and comp. vision
Shikoku Section	
<b>Shuxiang Guo</b>	for contributions to medical robots for minimally invasive surgery and biomimetic underwater robots
Singapore Section	
<b>Amit Gupta</b>	for leadership in power conversion systems
<b>Chau Yuen</b>	for contributions to energy efficient wireless communications
<b>Danwei Wang</b>	for contributions to modelling, analysis, and control for constrained robots
<b>Sanjib Panda</b>	for contributions to iterative learning control of motor drives
<b>Xudong Jiang</b>	for contributions to face and fingerprint image recognition
Tainan Section	
<b>Mi-ching Tsai</b>	for leadership in magnetic materials for the electric motor industry
Taipei Section	
<b>Ai-chun Pang</b>	for contributions to resource management and service provisioning for mobile edge networks
<b>Vincent Tseng</b>	for contributions to utility pattern mining and biomedical applications
<b>Yaow-ming Chen</b>	for contributions to grid-connected power converters for renewable energy applications
Tokyo Section	
<b>Hideaki Aochi</b>	for contributions to three dimensional flash memories
<b>Hideaki Ishii</b>	for contributions to networked control of large-scale systems
<b>Itsuro Morita</b>	for contributions to large-capacity transmissions systems with high-speed optical signals
<b>Jinhua She</b>	for contributions to intelligent control of complex metallurgical processes
<b>Shinji Yuasa</b>	for contributions to MgO-based magnetic tunnel junctions
<b>Takatoshi Tsujimura</b>	for contributions to the development of organic-light-emitting diode systems

Uttar Pradesh Section	
<b>Suresh Srivastava</b>	for contributions to power system security and stability
<b>Yogesh Chauhan</b>	for contributions to compact modeling of Si and GaN transistors
Victorian Section	
<b>Jianfei Cai</b>	for contributions to multimedia transmission and content analysis
Wuhan Section	
<b>Lizhe Wang</b>	for contributions to high performance comp. in proc., anal. and applications of remote sensing imagery
<b>Min Chen</b>	for contributions to data-driven communication, caching, and computing
Xian Section	
<b>Guangming Shi</b>	for contributions to image representation and image reconstruction
<b>Hong Wang</b>	for devel., integ., and comm. of novel dielectric ceramics and composites for passive integration
<b>Jiandong Li</b>	for leadership in heterogeneous self-organizing wireless networks
<b>Jingdong Chen</b>	for contributions to microphone array proc. and speech enhance. in noisy and reverb. environments
Zhejiang Subsection	
<b>Fushuan Wen</b>	for contributions to fault diagnosis in power grids
<b>Zheng Xu</b>	for contributions to control and modeling of modular multilevel converter based HVDC trans. systems
<b>Zhengyu Lu</b>	for contributions to DC-DC power conversion and control

# IEEE Regional Exemplary Student Branch Award 2020



## Bangalore Section

- ❖ University Visvesvaraya College of Engineering [UVCE]
- ❖ Central University of Karnataka

## Bangladesh Section

- ❖ BRAC University
- ❖ American International University - Bangladesh

## Bombay Section

- ❖ Sies Graduate School Of Technology
- ❖ Vidyalkar Institute of Technology

## Delhi Section

- ❖ Netaji Subhas University of Technology (NSUT)

## Hyderabad Section

- ❖ Gokaraju Rangaraju Institute of Engineering and Technology
- ❖ University College of Engineering, Osmania University

## Kerala Section

- ❖ Adi Shankara Institute of Engineering and Technology
- ❖ St. Joseph's College of Engineering and Technology, Palai
- ❖ Chengannur College of Engineering
- ❖ Rajiv Gandhi Institute of Technology Kottayam
- ❖ Government College of Engineering – Kannur
- ❖ College of Engineering – Karunagappally
- ❖ NSS College Of Engineering

## Madras Section

- ❖ Panimalar Institute of Technology - Chennai

## Malaysia Section

- ❖ Universiti Tenaga Nasional
- ❖ Monash University - Sunway Campus
- ❖ Universiti Teknikal Malaysia Melaka
- ❖ Multimedia University
- ❖ Malaysia Universiti Teknologi
- ❖ University of Malaya
- ❖ Putra Malaysia University
- ❖ Curtin University Sarawak
- ❖ Universiti Malaysia Perlis

## Sri Lanka Section

- ❖ University of Colombo School of Computing

## IEEE REGIONAL EXEMPLARY STUDENT BRANCH AWARD 2020

### RESULTS

**Congratulations** to all the winners. For more information about the IEEE Student Awards, please visit our awards page at [students.ieee.org/awards/](https://students.ieee.org/awards/)

 [STUDENTS.IEEE.ORG](https://students.ieee.org)  [@IEEESTUDENTS](https://www.facebook.com/IEEESTUDENTS)

# IEEE Darrel Chong Student Activity Award 2020



## Gold Category

- ❖ *IEEE Student Quality Improvement Programme 2019* - Chengannur College of Engineering, **Kerala Section**
- ❖ *IEEE STEM Challenge Tech Track and Science Track* - Curtin University - Sarawak, **Malaysia Section**
- ❖ *Credenz (National Technical Fest)* - Pune Institute of Computer Technology, **Pune Section**

## IEEE DARREL CHONG STUDENT ACTIVITY AWARD 2020

### RESULTS

**Congratulations** to all the winners. For more information about the IEEE Student Awards, please visit our awards page at [students.ieee.org/awards/](https://students.ieee.org/awards/)

## Silver Category

- ❖ *Outreach Program for Pre-University Students* - Bangladesh Univ Of Engineering & Technology, **Bangladesh Section**
- ❖ *Umang* - Guru Gobind Singh Indraprastha University, **Delhi Section**
- ❖ *Intel Softwares IoT Workshop* - The NorthCap University, **Delhi Section**
- ❖ *EMPNEO 3.0* - Model Engineering College, **Kerala Section**
- ❖ *Brainstorm 2019* - University of Moratuwa-Sri Lanka, **Sri Lanka Section**
- ❖ *Gammeddata IEEE Api (IEEE for the Countryside)* - University of Moratuwa-Sri Lanka, **Sri Lanka Section**

[STUDENTS.IEEE.ORG](https://students.ieee.org) [@IEEESTUDENTS](https://www.facebook.com/IEEESTUDENTS)

## Bronze Category

- ❖ *Student Professional Awareness Workshop* - American International University - Bangladesh, **Bangladesh Section**
- ❖ *hackNSUT 2019* - Netaji Subhas University of Technology (NSUT), **Delhi Section**
- ❖ *IEEE Awareness talk and IEEE Project for Kids: Renewable Energy for Future* - Indian Institute of Technology-Mandi, **Delhi Section**
- ❖ *IEEE Fusion* - Institut Teknologi Bandung, **Indonesia Section**
- ❖ *Kaizen 6.0* - College of Engineering, Munnar, **Kerala Section**
- ❖ *.hack();* - Mar Athanasius College of Engineering, Kothamangalam, **Kerala Section**
- ❖ *42 - Technical Flagship Event* - Government Engineering College - Barton Hill, **Kerala Section**
- ❖ *Lighting for Humanity* - College of Engineering - Karunagappally, **Kerala Section**
- ❖ *All Pakistan Electrical Symposium* - Univ of Engineering and Tech - Lahore, **Lahore Section**
- ❖ *11<sup>th</sup> IEEE Annual Engineering Project Exhibition* - UCET - The Islamia University of Bahawalpur, **Lahore Section**
- ❖ *InternEXP* - University of Nottingham - Malaysia Campus, **Malaysia Section**
- ❖ *Hackaholics 3.0* - University of Colombo School of Computing, **Sri Lanka Section**
- ❖ *GameRush* - University of Colombo School of Computing, **Sri Lanka Section**
- ❖ *Let Me Hack Eco 2.0* - Sabaragamuwa University of Sri Lanka, **Sri Lanka Section**

# IEEE Outstanding Branch Counselor and Chapter Advisor Award 2020



## IEEE OUTSTANDING BRANCH COUNSELOR AND BRANCH CHAPTER ADVISOR AWARD 2020

### RESULTS

**Congratulations** to all the winners. For more information about the IEEE Student Awards, please visit our awards page at [students.ieee.org/awards/](https://students.ieee.org/awards/)

 [STUDENTS.IEEE.ORG](https://students.ieee.org)  [@IEEESTUDENTS](https://www.facebook.com/IEEESTUDENTS)

*Dr. Asjad Amin, UCET - The Islamia University of Bahawalpur, Lahore Section*

*Dr. Mohamad Yusoff Alias, Multimedia University, Malaysia Section*

*Dr. Vydeki Vijayakumar, Vellore Institute of Technology - Chennai, Madras Section*

*Prof. Haseena P Y, College of Engineering, Karunagapally, Kerala Section*



## IEEE GLOBAL STUDENT BRANCH WEBSITE CONTEST 2020

### RESULTS

**Congratulations** to all the winners. For more information about the IEEE Student Awards, please visit our awards page at [students.ieee.org/awards/](https://students.ieee.org/awards/)

 [STUDENTS.IEEE.ORG](https://students.ieee.org)  [@IEEESTUDENTS](https://www.facebook.com/IEEESTUDENTS)

#### 1<sup>st</sup> Place (Winner)

Pueruana Cayetano Heredia University, Peru Section (R9)

<https://www.ieee-upch.org/>

#### 2<sup>nd</sup> Place (Runner)

**Universiti Teknikal Malaysia Melaka, Malaysia Section (R10)**

<https://edu.ieee.org/my-utem/>

#### Honourable Mention(s)

Universidade do Porto, Portugal Section (R8)

<http://ieee.fe.up.pt/>

UPIITA - IPN, Mexico Section (R9)

<https://ieeepiita.mx/>



## LARRY K WILSON REGIONAL STUDENT VOLUNTEER AWARD 2020

### RESULTS

**Congratulations** to all the winners. For more information about the IEEE Student Awards, please visit our awards page at [students.ieee.org/awards/](https://students.ieee.org/awards/)

 [STUDENTS.IEEE.ORG](https://students.ieee.org)  [@IEEESTUDENTS](https://www.facebook.com/IEEESTUDENTS)

R7 - Annika Benson, Dalhousie University, Canadian Atlantic Section

R8 - Theodoros Panagiotis Chatzinikolaou, Democritus Univ of Thrace, Greece Section

R9 - Jonathan Humberto Luzon Carrion, Politecnica Salesiana University, Ecuador Section

***R10 - Ali Mustufa Shaikh, A. P. Shah Institute of Technology, Bombay Section***



# CONFERENCE CALL FOR PAPERS





# CONFERENCE CALL FOR PAPERS

## Welcome to Auckland, New Zealand Host city of TENCON 2021



## Choose to have it all in Auckland, New Zealand in 2021.

  
**HOST CITY**  
Auckland, New Zealand

  
**PROPOSED DATES**  
7-10 December 2021

  
**PROPOSED VENUE**  
TBC

# IEEE TENSYP 2021

Connected Intelligence for Smart IT, Jeju, Korea

~~April 21 (Mon) – 23 (Wed), 2021~~

August 22 (Sun) – 24 (Tue), 2021



Due to COVID-19, the TENSYP2021 organizing committee has decided to postpone TENSYP2021 to August 22 (Sunday) - 24 (Tuesday), 2021.

The committee has also decided to change the conference Venue to Maison Glad Jeju Hotel (<https://maisongladjeju-hotels.com/web/maison/about>).

The conference will be run in mixed online and physical mode.

# **IEEE R10 NEWSLETTER**



# **IEEE REGION 10 TODAY**

JANUARY  
**2021**  
EDITION