

Application of Robotic Technologies to Mountain Rescue

Claudio Melchiorri

CAI — Italian Alpine Club
University of Bologna



- Mountain search and rescue operations:
 - Some statistics
 - Winter scenario
 - Summer scenario
- The **SHERPA project** and its vision
 - Robotic technologies
 - The “donkey”
 - The “hawks”
 - The “wasps”
- Conclusions

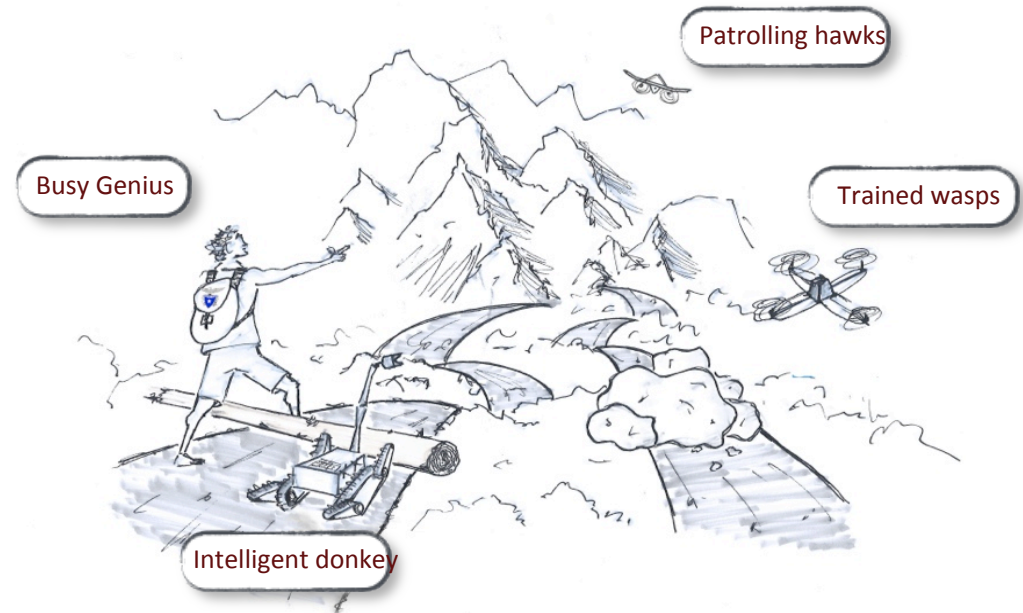

- Very engaging environment because of
 - Rough terrain
 - Weather
 - Dangerous conditions
 - Poor visibility
 - Communication problems
 - Logistics
 - ...

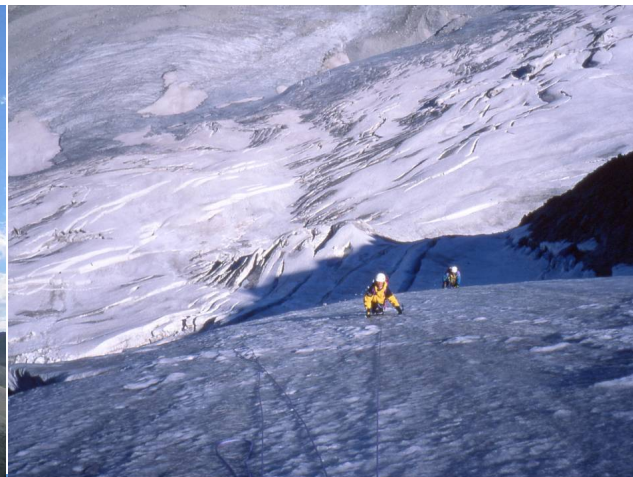

- Although international associations exist (e.g. the *Internationale Kommission für Alpines Rettungswesen* - IKAR-CISA), there is no common “practice” in organizing search and rescue operations in mountains:
 - Italy: based on volunteers (CNSAS of CAI)
 - UK: volunteers (& military force)
 - France: Gendarmerie Nationale (para-military police force)
 - CH: REGA (private association)
 - Japan: police & private associations
 - USA: professional teams within national parks or volunteer teams
 - Russia: volunteers (in very few areas, no helicopters...)
 - ...
- Difficult to have an unified scenario/protocol of intervention
- Different countries have in general different “problems”



- CNSAS is a branch of CAI, the Italian Alpine Club
- It is a non-profit, non-political organization, devoted to search and rescue operations in mountains and caves
- It consists in more than 7.000 volunteer technicians, organized in about 250 rescue teams, covering the Italian territory
- > 6.000 operations per year
- It is a national body of the National Service for Civil Protection.



Some statistical data from CNSAS:

- Rescue operations in Italy
- Rescue operations with helicopters
- Winter/Summer operations
- Avalanche accidents
- Fatalities in avalanches

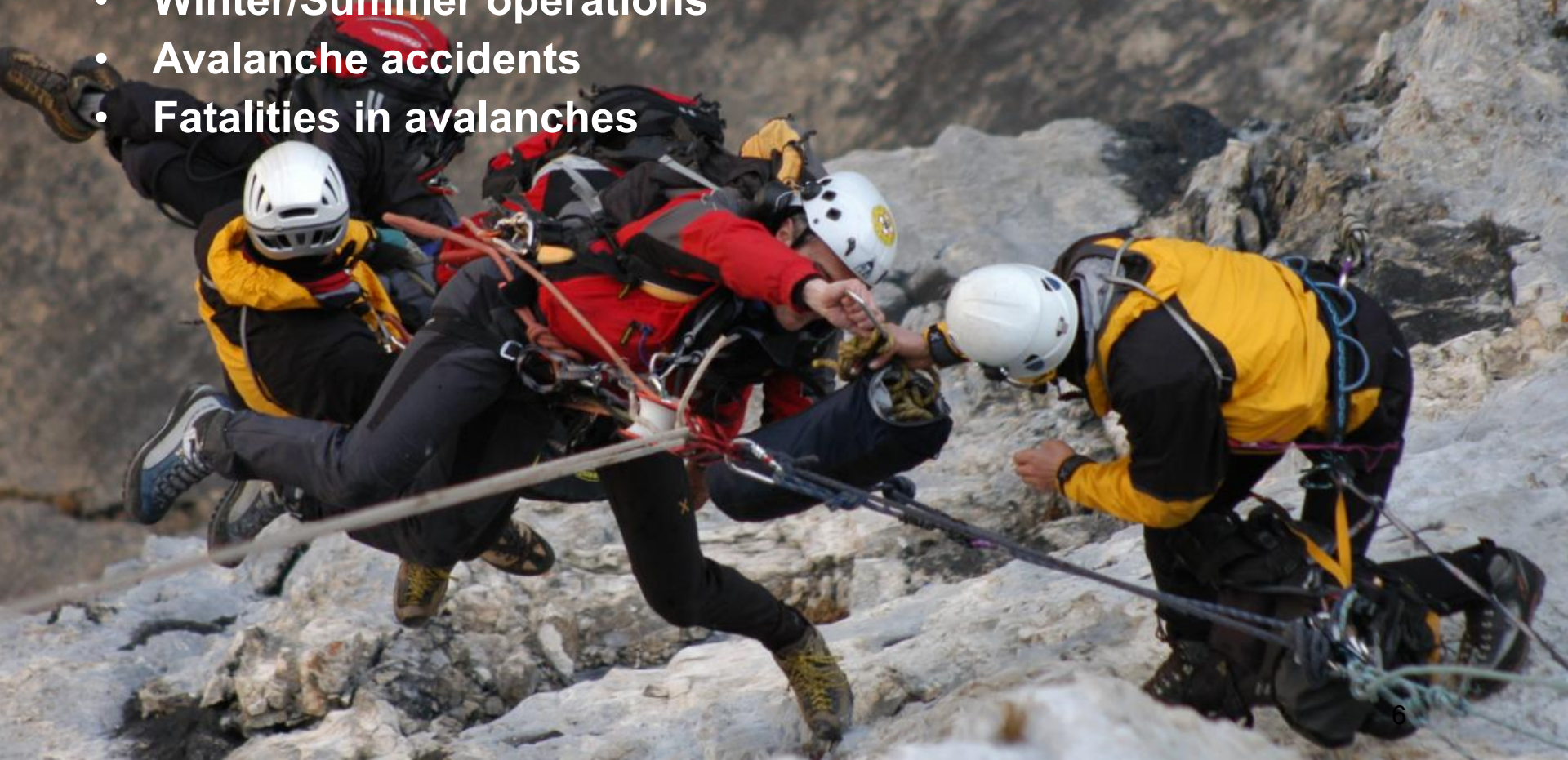

OPERATIONS 1955-2012

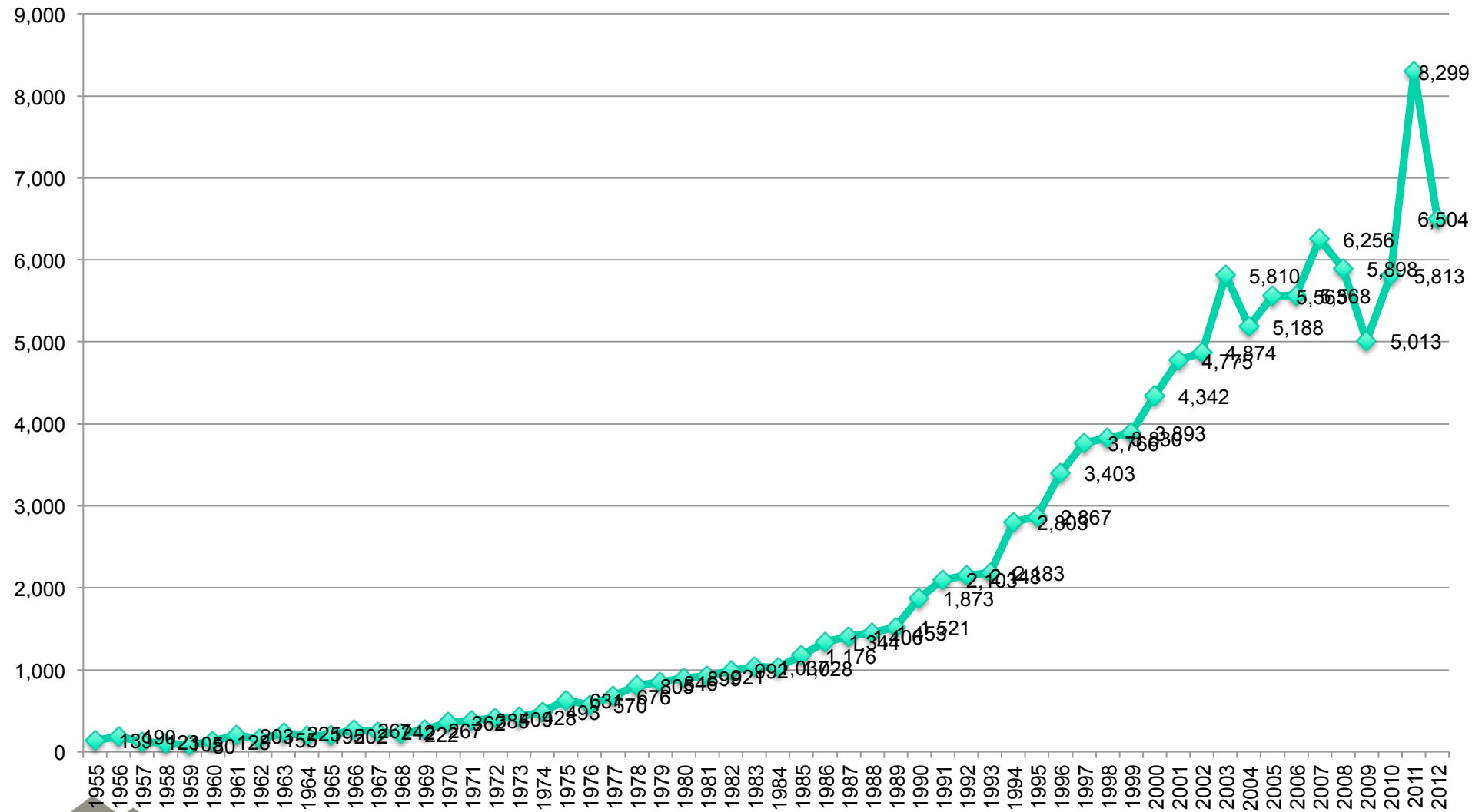

Rescuers

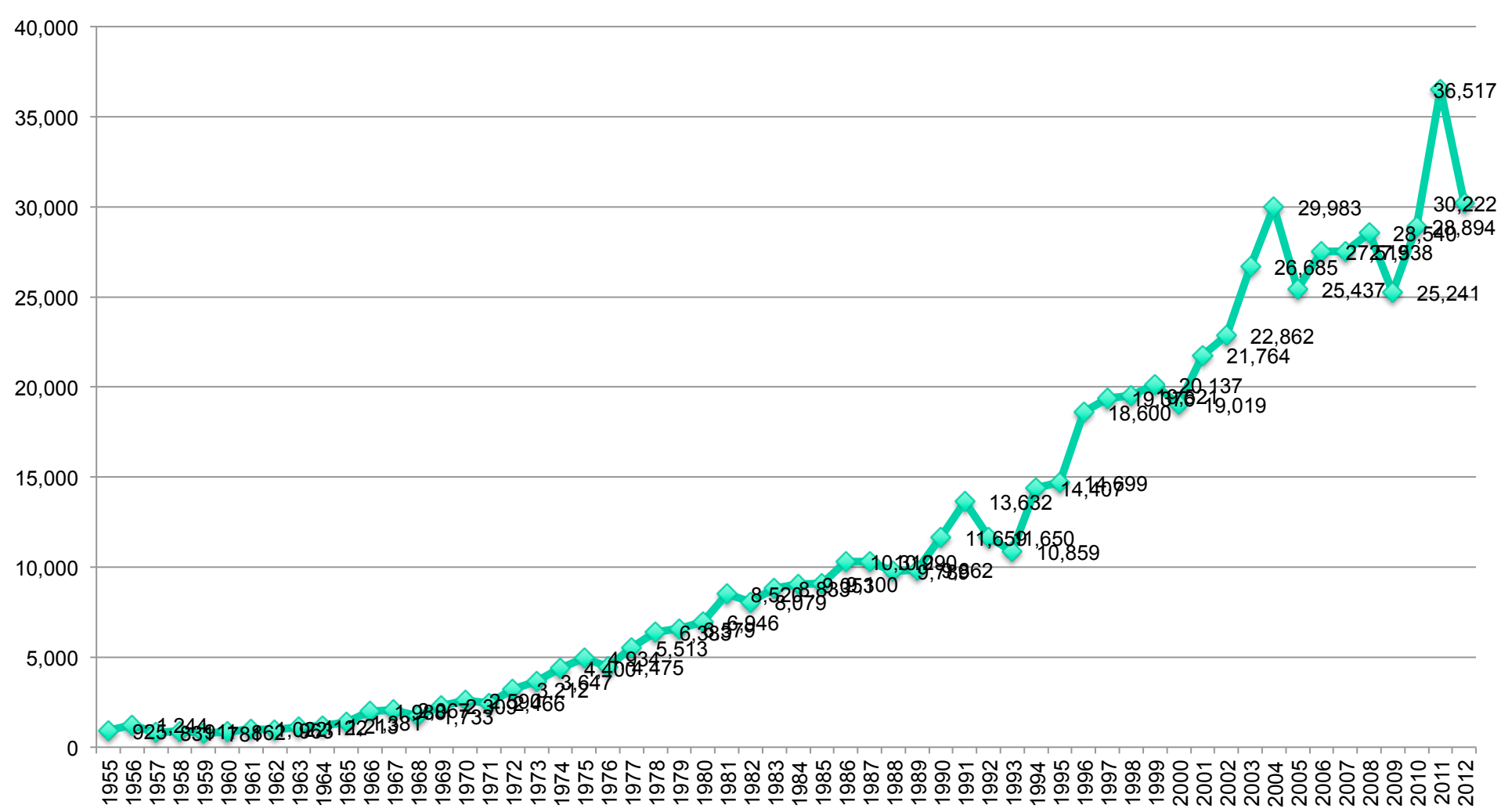

Helicopters

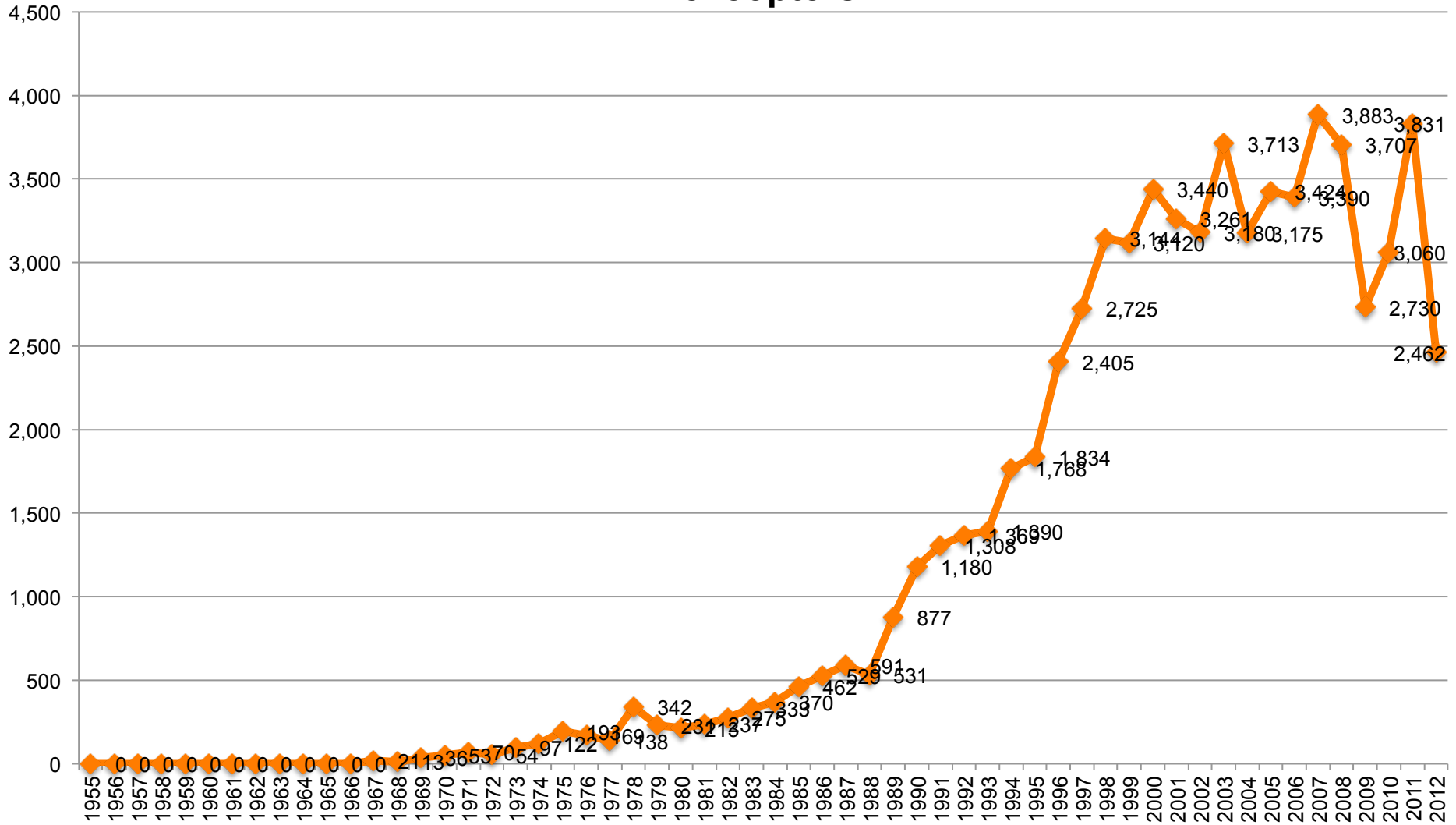

Month	# Int.	Perc.
January	602	9.3%
February	723	11.1%
March	491	7.5%
April	260	4.0%
May	277	4.3%
June	454	6.7%
July	843	12.7%
August	1173	18.0%
September	665	10.2%
October	444	6.8%
November	199	3.1%
December	411	6.3%
TOT	6542	

June – September: about 50%
 December – February: about 30%

Activity	# Int.	Perc.
Hiking	2346	35.9%
Climbing	627	9.6%
Mushroom hunting	357	5.5%
Mountain biking	263	4.0%
Tourism related act.	210	3.2%
Paragliding	85	1.3%
Winter (ski resort)	920	14.1%
Winter (off track)	175	2.7%
Winter (avalanche)	44	0.7%
Other	1515	23.2%
TOT	6542	

Cause	# Acc	Perc.
Fall	2062	31.5%
Disorientation	817	12.5%
Stroke	707	10.8%
Slide	481	7.4%
Inability	449	6.9%
Weariness	150	2.3%
Falling rocks	65	1.0%
Other	1811	27.7%
TOT	6542	

Many different types of rescue operations:

WINTER:

- Sky (resort / off-piste)
- Avalanches
- Ice climbing
- “High” altitude
- ...

SUMMER

- Search of missing persons
- Paragliding / Biking / Canyoning
- Rock climbing
- “High” altitude
- ...



Different environmental conditions

WINTER:

- Cold temperatures (-30°)
- Shorter days
- Mobility difficulties (snow)
- Generally: worse weather

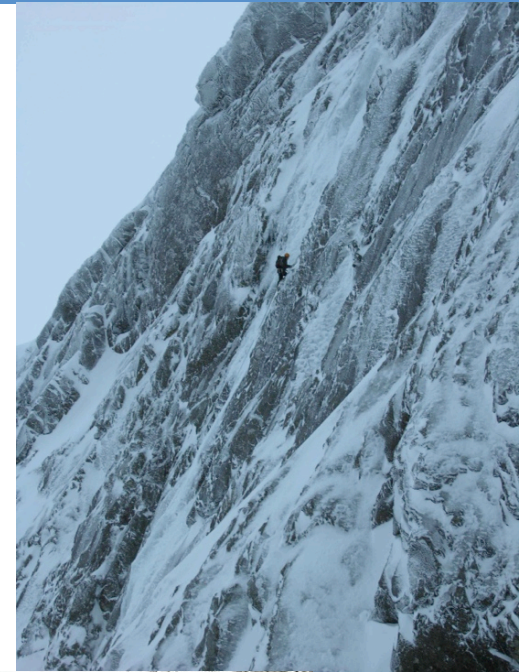

Different environmental conditions

SUMMER:

- Temperatures (-10° ÷ +40°)
- Stronger thermal activity (wind)
- Mobility problems related to vegetation
- Generally: much larger areas to be patrolled



- Search & rescue activities:
 - **Avalanches**
 - Search of lost persons
- Protocols for operations
- Composition and competencies of rescue teams



Fatalities 2009/2010

Total: 45

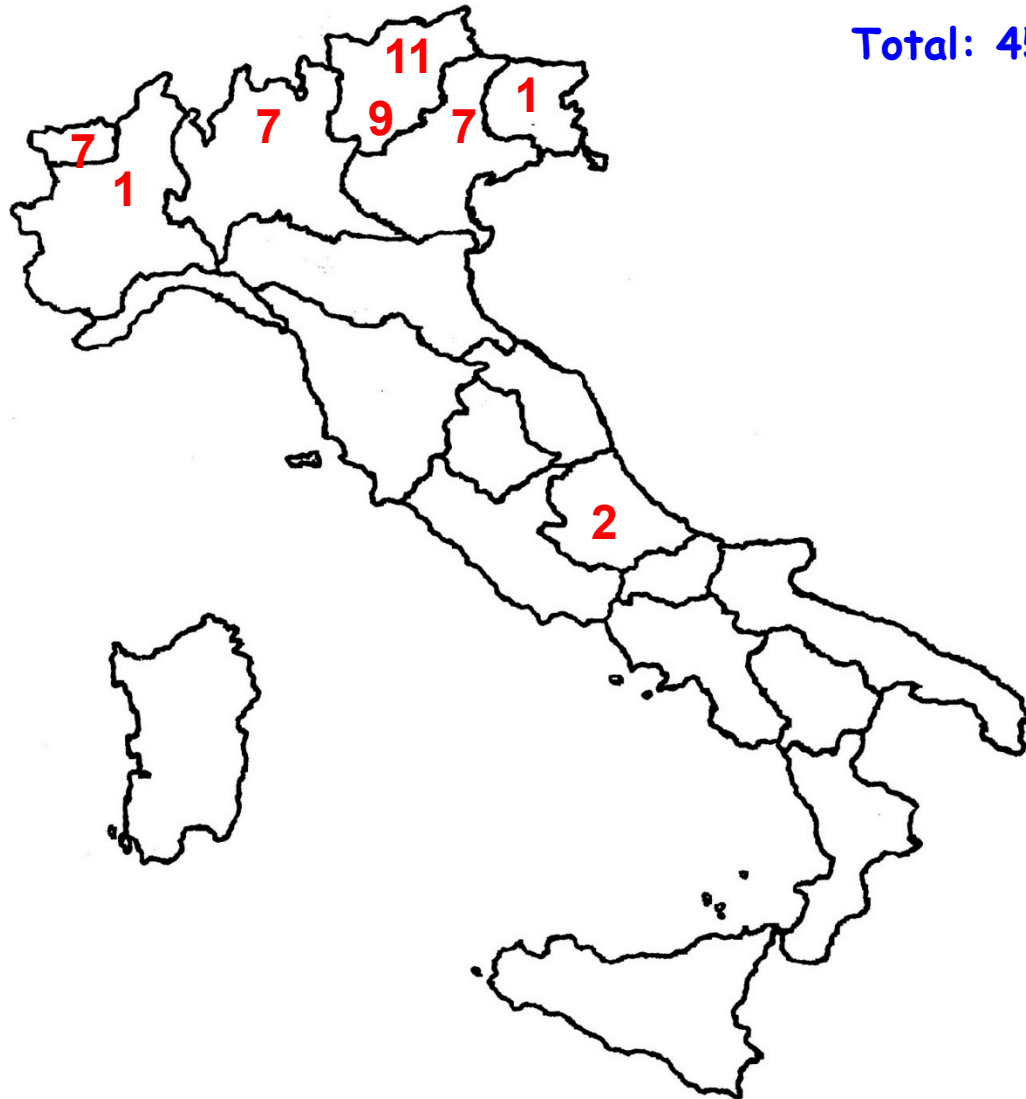

Fatalities 2010/2011

Total: 16

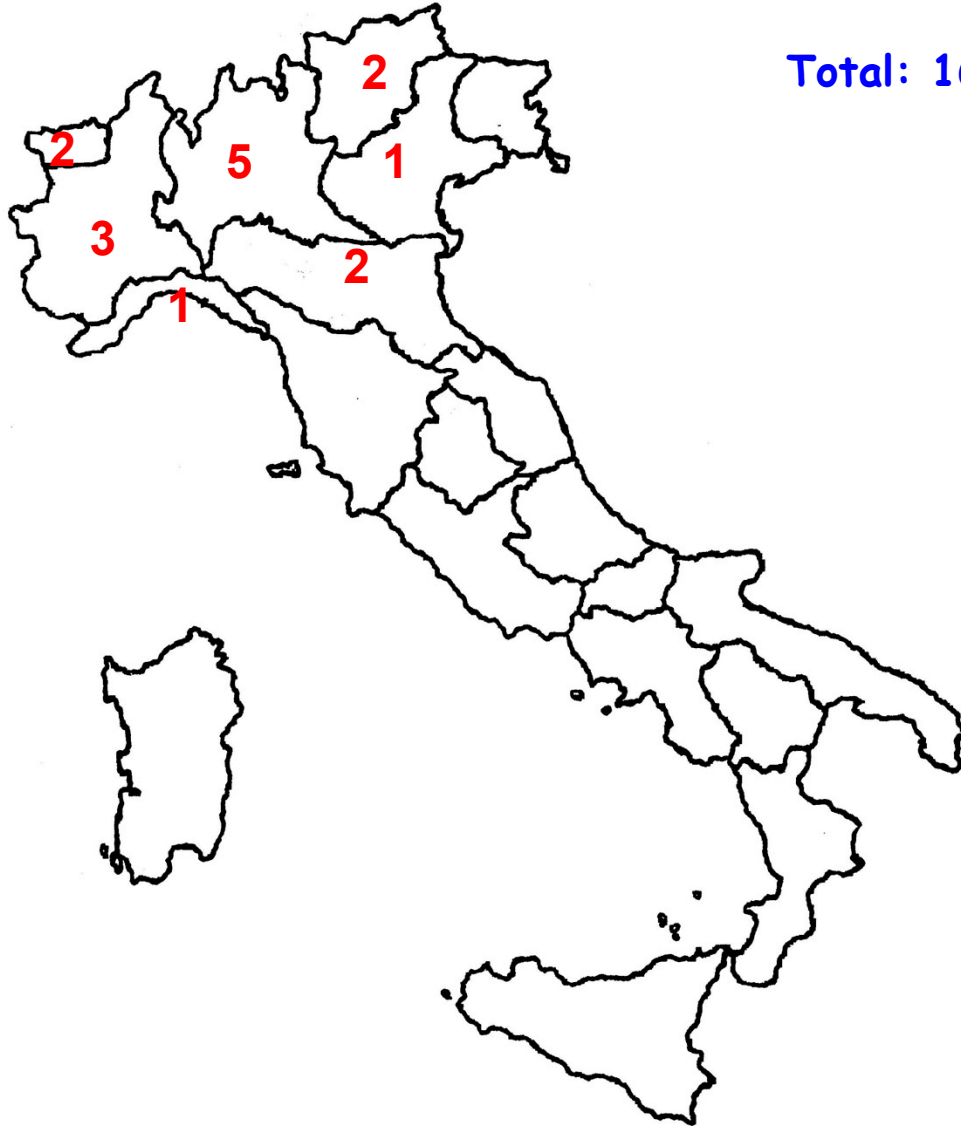

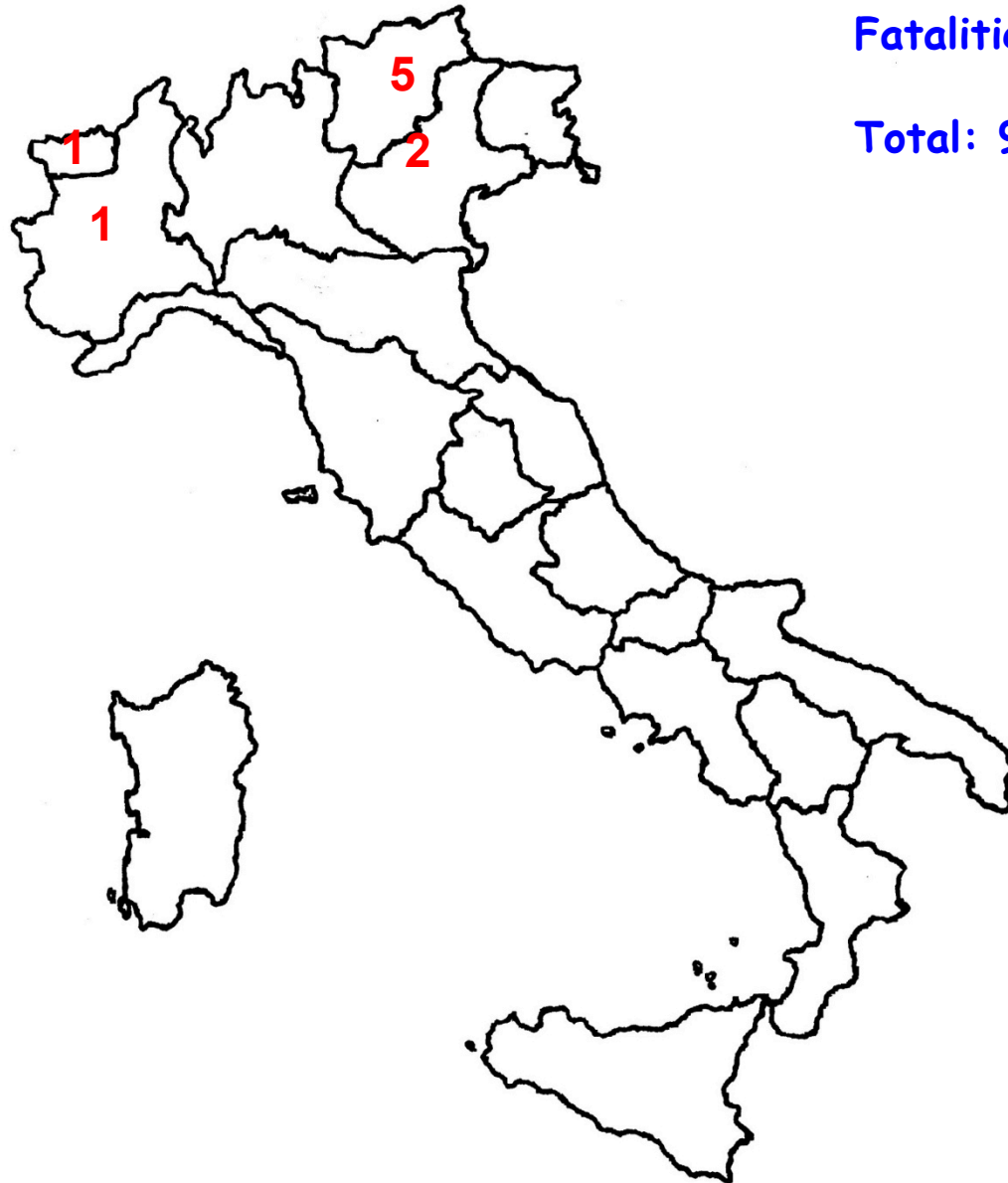

Fatalities 2011/2012

Total: 9



Trend of fatalities in Italy from 1986 to 2012

In Italy, in average 18 persons die every year

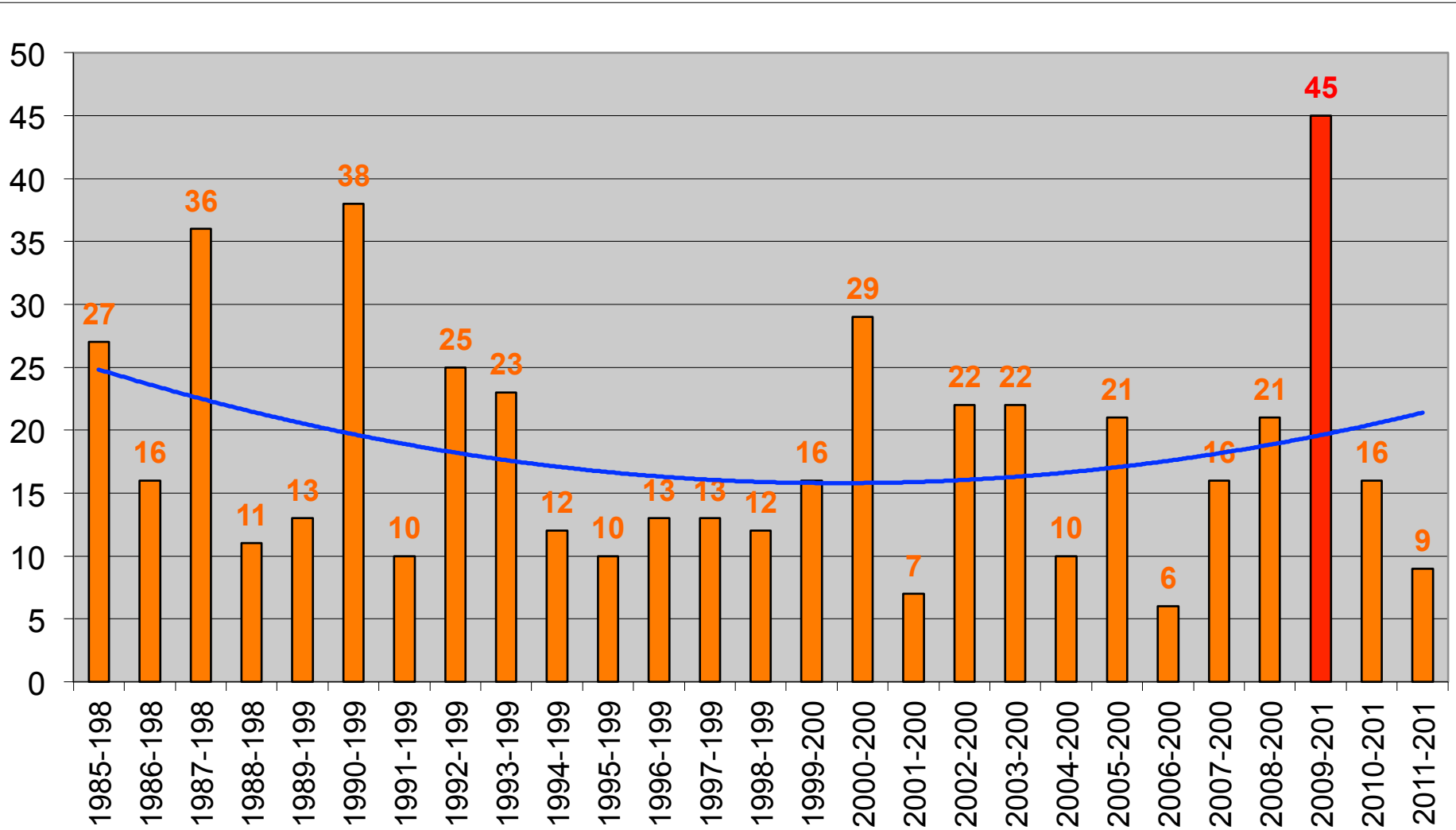

Avalanche fatalities since 1936/37

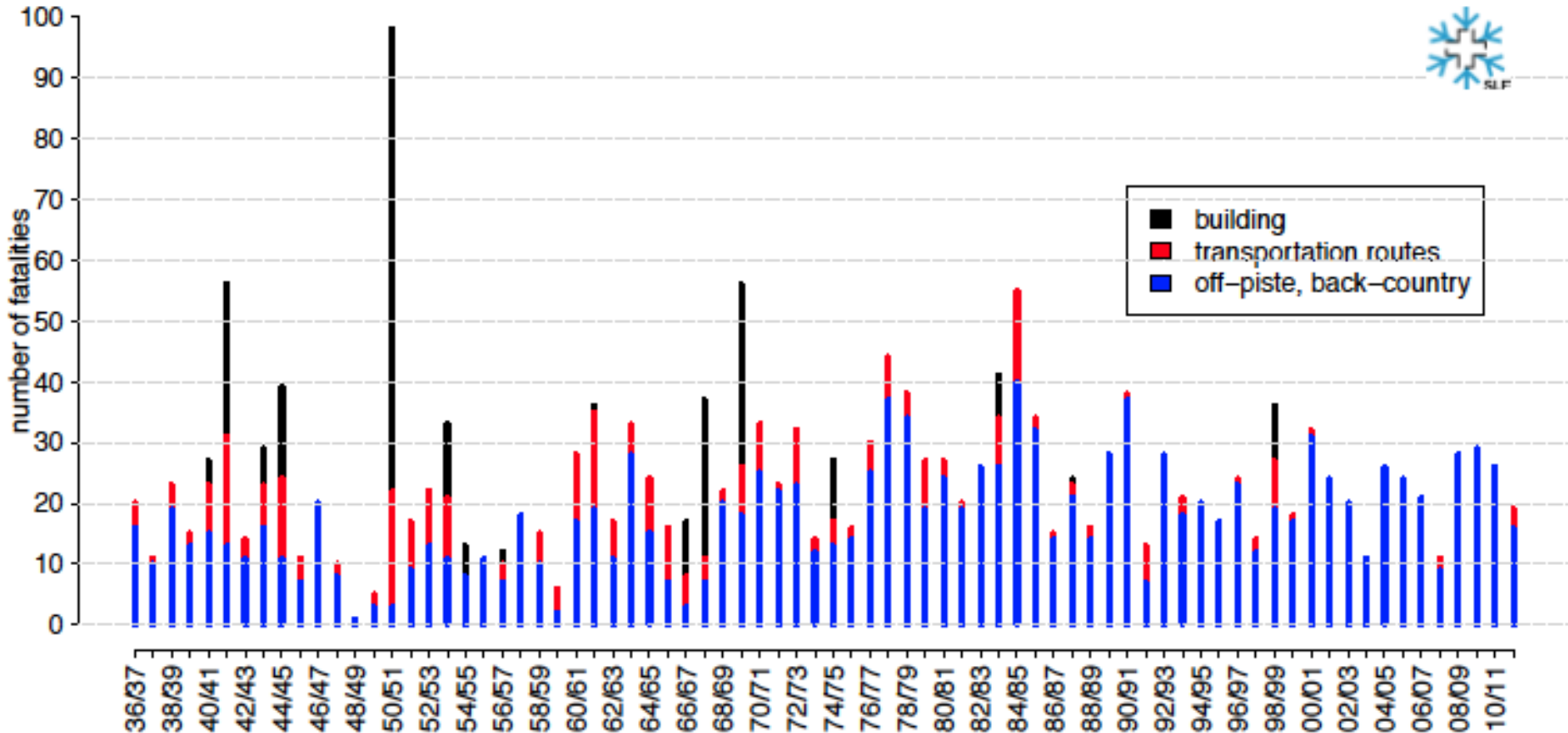

Many different types of avalanches:

- Powder snow
- Blocks of heavy “stiff” snow
- Spring/Winter avalanches
- Snow: 300 – 600 kg/m³





Three main areas

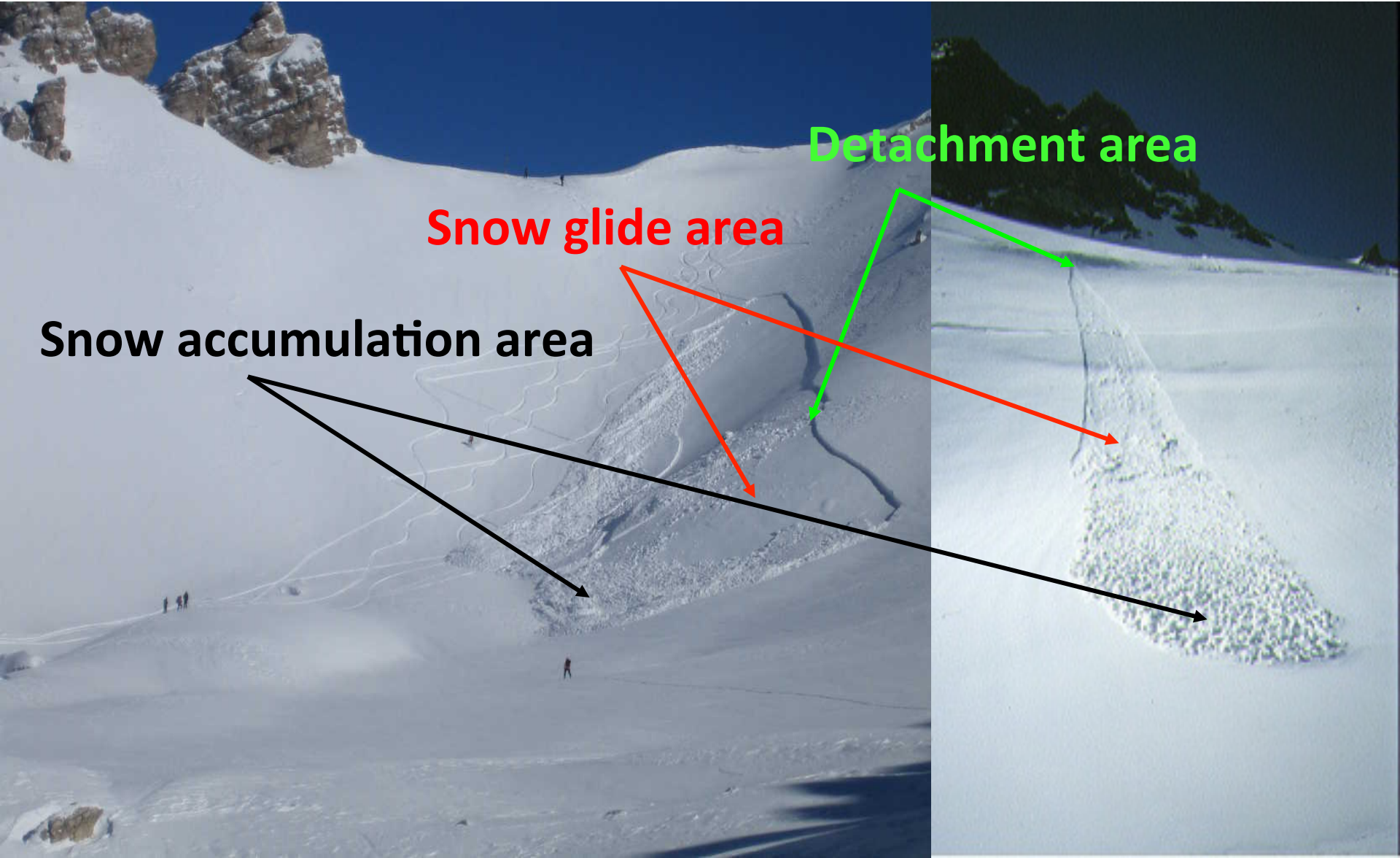

“Typical” conditions

- Average surface to scan: 50 x 200m (10000 m²)
- Average snow stockpile surface (5000 m²)
- Depth of buried persons: 0.70 – 1.00 m (avg)
- Wind: Peak: 100 Km/h (54 knots); Average: 35-55 Km/h (20-30 knots); non constant in direction and force (impulses)
- Temperature: up to -20°C
- Altitude: typically <=3500 m; 4000m must be considered
- Low visibility: snow, rain, fog
- GSM not always working
- Backpack with technical equipment of rescuer not really heavy (< 5 Kg)

Moreover:

- Number/conditions of buried persons
- Danger of other avalanches
- ...



Currently available technologies for finding buried persons

- Avalanche beacon (ARTVA, signal up to 30-40 m, weight 200 g, worn only by 50% of people)
- RECCO (passive system worn by very few people, R9 detector: weight 900 g, dimension as a school book, signal in the snow up to 20 m)



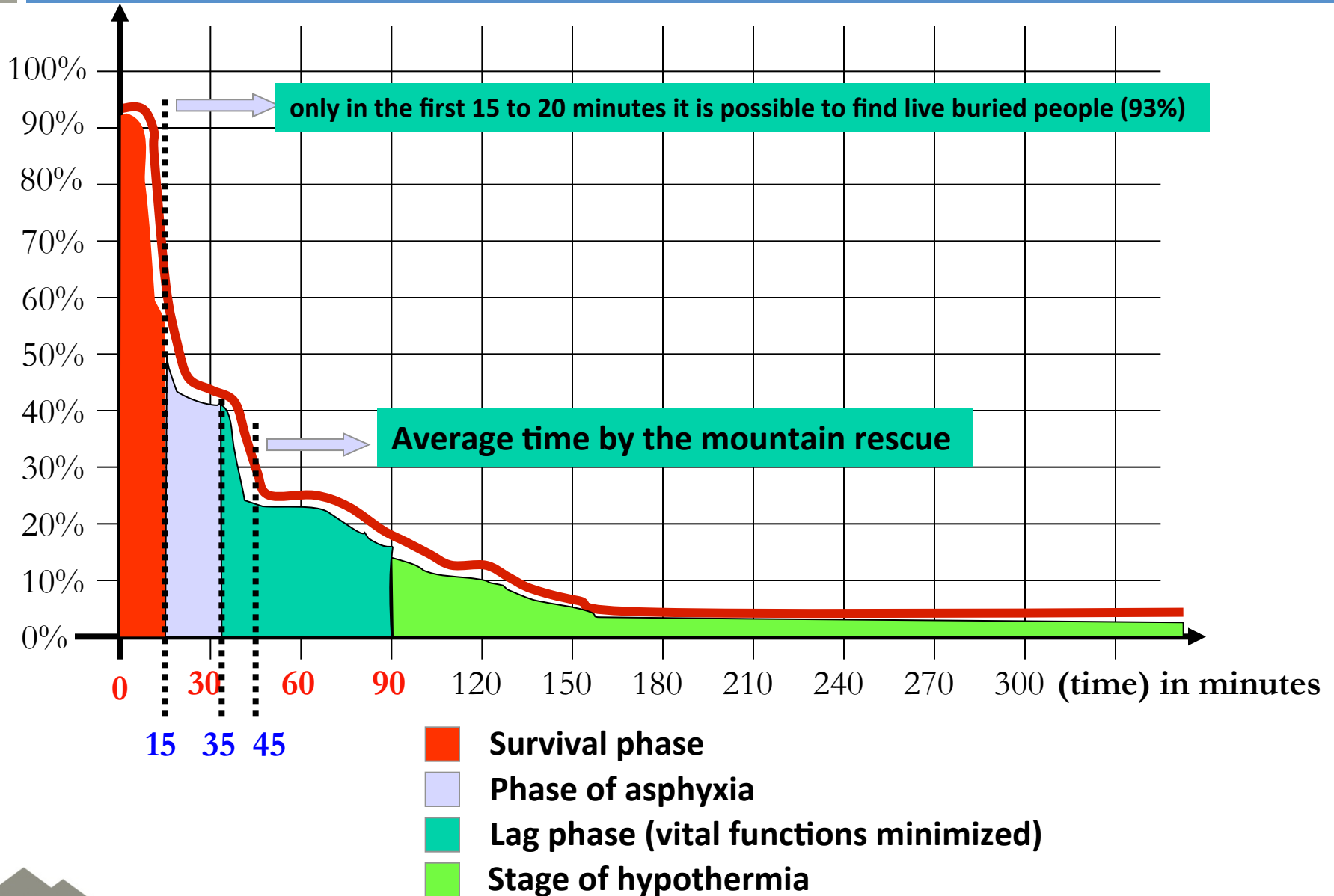

When possible, self-rescue by companions is the best option!

- Use of avalanche beacons, probe, snow shovel
- Well coordinated actions by group
- Well defined “search and extraction” procedure



Searching Procedure with ARTVA

The search procedure with an ARTVA is divided into three phases:

- PHASE 1: detection of the signal (patrolling the avalanche area)
- PHASE 2: follow the electro-magnetic field along the field lines (distance from the buried ARTVA: starts from 20-30 m to 3 m)
- PHASE 3: fine search (within 3 m)



*No ARTVA signal:
First phase*



*ARTVA signal:
Second phase*



*Strong ARTVA signal:
Third phase*



If self-rescue is not possible

- Alert of the rescue team (118-112)
- Intervention helicopter (only if the weather is ok)
- The first team consists of:
 - technical alpine rescuers
 - dog handler
 - medical doctor
- If the problem is complex and is not solved by the first team, other personnel will be transported to the avalanche site
- If helicopters cannot fly, rescuers must use skis or snowshoes, involving a huge amount of time and increasing the probability of fatalities



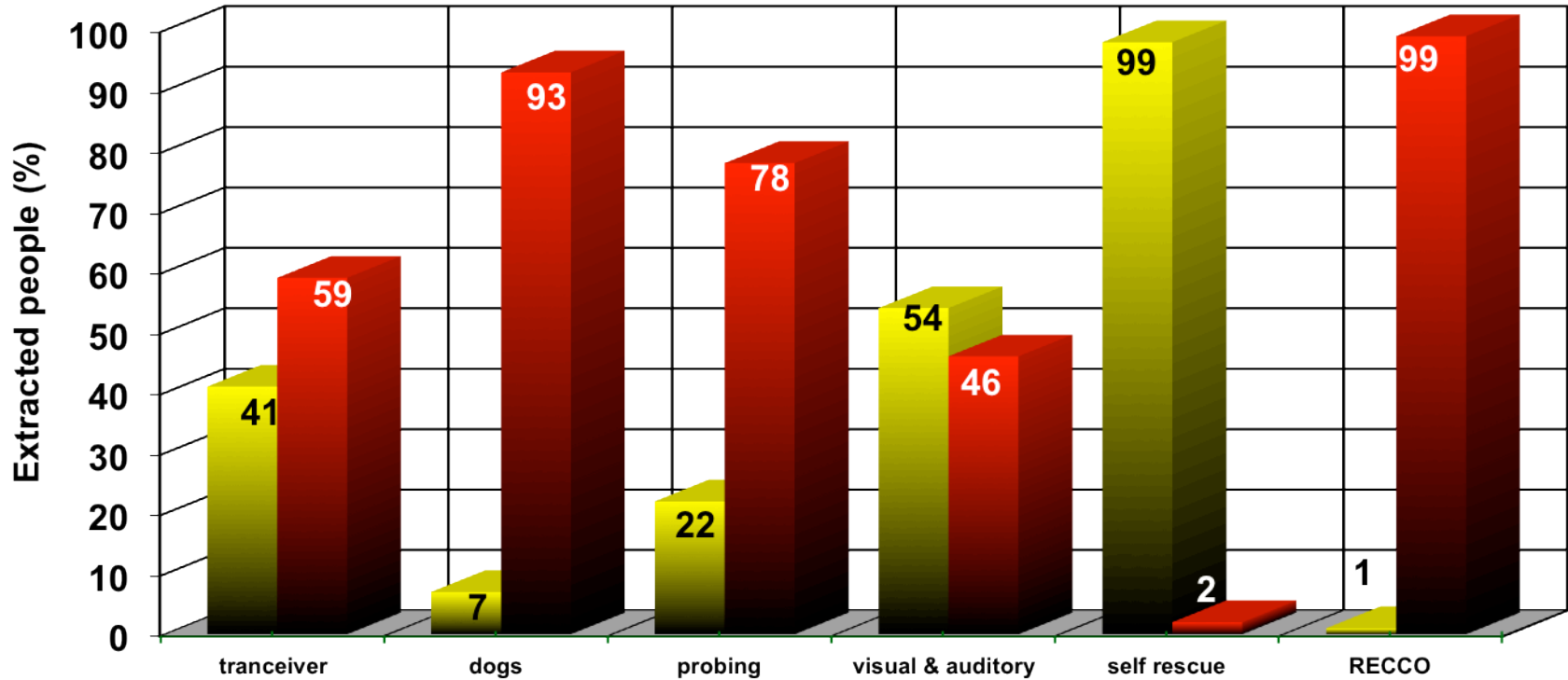

■ alive

■ dead

Problems in avalanche rescue (snow terrain)

- distance from the target
- mobility difficulties in snow terrains:
 - need to move very quickly among big blocks of hard snow
 - need to move in soft and deep snow
- bad weather (snow – wind – fog)
- danger of other avalanches
- the number of victims is not always known
- it is not always possible to know if victims are equipped with beacons
- the beacons of the victims may be switched off
- survivors are in shock conditions
- the sanitary condition of the victims is always unknown

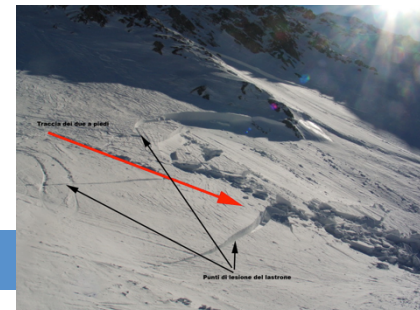

- Search & rescue activities:
 - Avalanches
 - **Search of lost persons**
- Protocols for operations
- Composition and competencies of rescue teams



Summer vs Winter operations

WINTER:

- Number of avalanche rescues in a season: approx 40-50 (in Italy);
- Number of rescued persons in 2010 (avalanches, Italy): 189

SUMMER:

- Number of operations approx 30-40 per week (in a single region, e.g. Valle d'Aosta or Trentino);
- number of operation in Italy in 2010: 5813
- rescued persons in Italy in 2010: 6027



Lost in Italian mountains

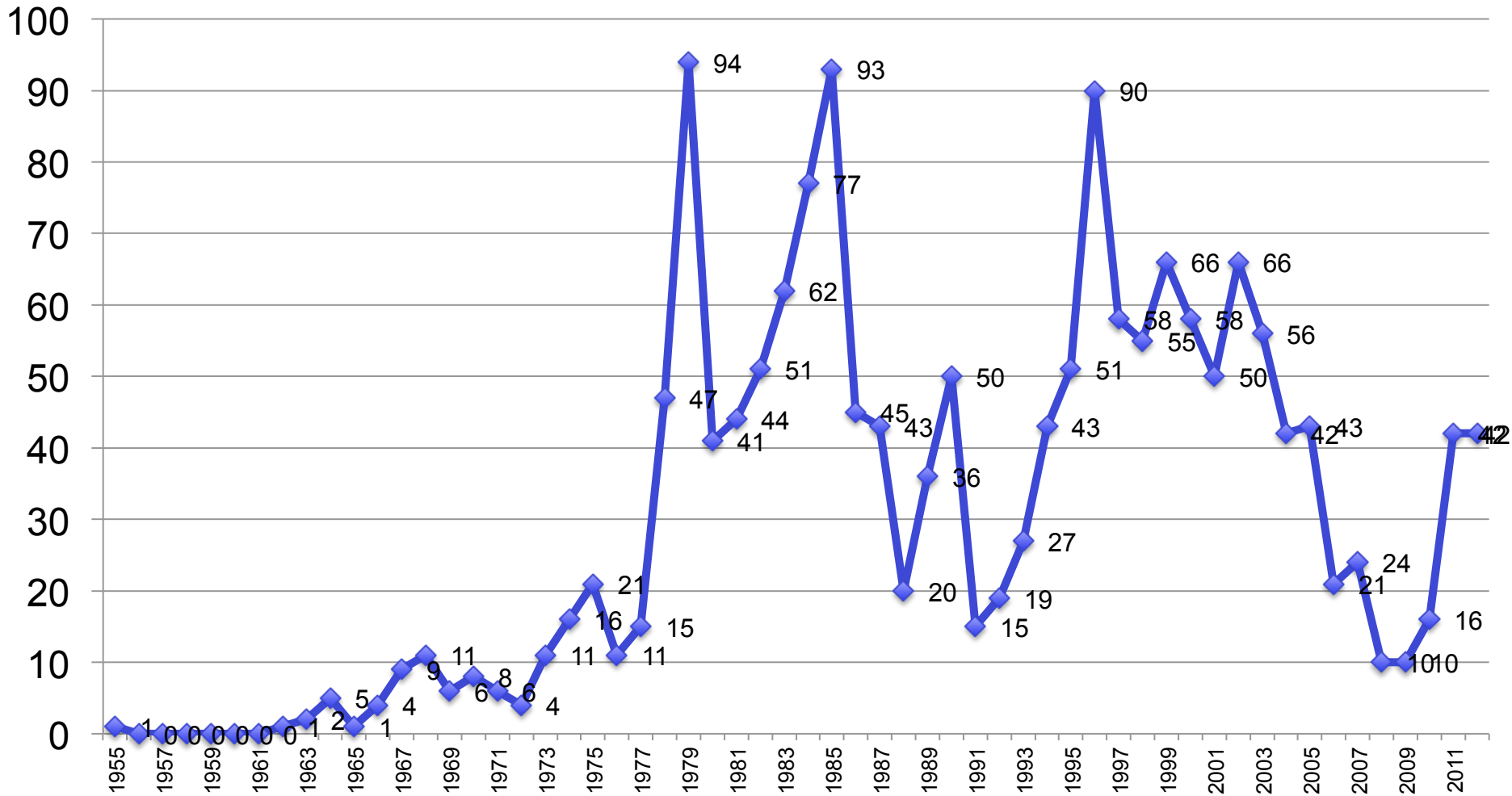

A “typical” search mission

- The emergency unit receives the call (through the 118, police, etc)
- The rescue team gets close to the area (by car)
- By means of molecular dogs possible search directions (e.g. valleys) are identified.
- Teams of about 4/5 persons start combing clusters according to pre-specified “algorithms”.
- Search sessions last about 4 hours. Altitude gap ± 800 m, ± 3 Km distance by foot.
- No specific sensors are used. Just sight-hearing mode
- Difficult to guarantee 100% that the person is not in the searched area
- “Probabilistic” approach in designing the search areas



Operative conditions

- Average surface to patrol: no limit, depends on many factors.
- Wind: Average: 27-37 Km/h (15-20 knots).
- On rocky walls: thermal vertical wind from bottom: 10 knots
- Temperature: 0 – 20° C
- Altitude: typically less than 3000 m
- GSM not always working
- Terrain, any kind:
 - rocks (different altitude)
 - grass (different altitude)
 - forest (under 2500m of altitude)



Difficulties in search operations

- very difficult terrain
- mobility difficulties:
 - steep slopes, cliffs, vegetation
 - many natural obstacles (trees, rocks, creeks, ...)
- possible bad weather (wind – fog - rain)
- poor visibility conditions (even night operations)
- large areas to be explored
- coordination of relatively large groups of rescuers, possibly with different competencies and skills (CNSAS, Civil Protection, fire-fighters, Army, ...)
- operations may last for several days



Winter

- Patrolling of ski-resort areas (evening)
- Deployment of first-aid equipment



Summer

- Deployment of first-aid equipment
- “Cable” operations (paragliders)



Smart collaboration between Humans and ground-aerial Robots for imProving rescuing activities in Alpine environment

Goals:

- Development of mixed **ground and aerial robotic platforms** to support Search and Rescue missions
- Use in a **real-world hostile environment** like the alpine scenario
- Modes of **interaction and task allocation** amongst human and robotic actors with complementary capabilities
- Development of **sharing and processing sensory data** techniques for robotic and human navigation and for people search
- Address a number of research topics about **cognition and control**

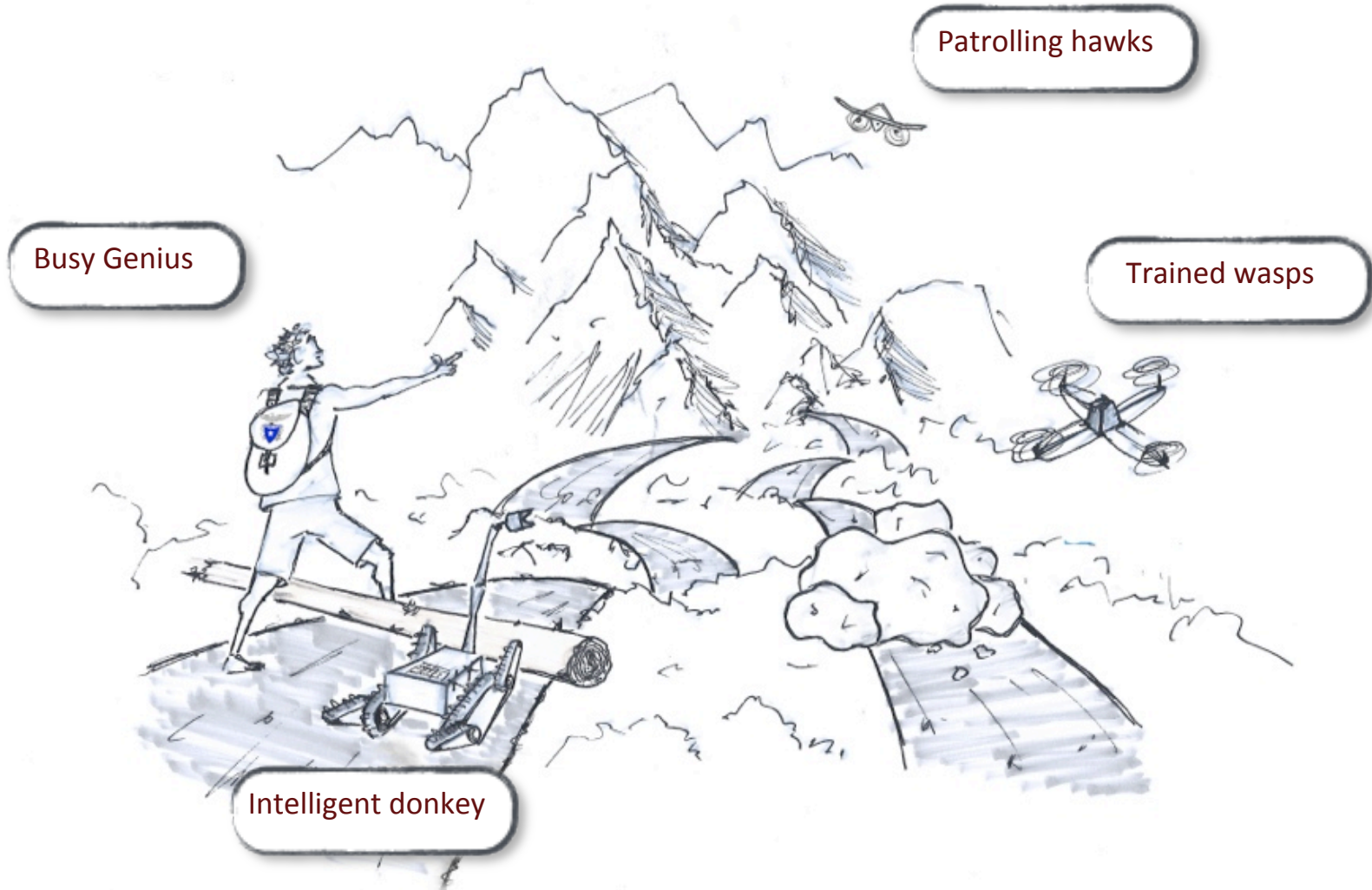

Part. #	Institution	Country	Leading scientists
1 (coord)	Università di Bologna		Lorenzo Marconi
2	University of Bremen		Micheal Beetz
3	ETH Zurich		Roland Siegwart
4	University of Twente		Raffaella Carloni
5	University of Leuven		Herman Bruyninckx
6	Linkopings University		Patrick Doherty
7	Università di Napoli Federico II		Vincenzo Lippiello
8	Aslatech (SME)		Andrea Sala
9	Bluebotics (SME)		Nicola Tomatis
10	Club Alpino Italiano		Andreina Maggiore

“Busy genius”

- **A human rescuer**, expert of the specific rescuing mission or surveillance activity (e.g. a mountain guide, a specifically trained specialist, a forest guard, ...)
- The human transmits wirelessly his position to the robotic platform and communicates to it through handy and easy-to-operate technological devices
- **“busy genius”**
 - Incomparable cognitive capabilities
 - Often “distracted” by demanding rescuing activity (“sketchy inputs”)



“Trained wasp”

- **Small-scale UAVs** with onboard cameras/receivers
- Improved surveillance, capability of reaching rapidly a target location in the neighborhood of the team, increasing the patrolled rescuing area (“**flying eyes**”)...
- Handy devices:
 - Technically conceived to be supervised by the human in simple and natural way
 - Safe and operable in the vicinity of the human (hand deployment)
- Multi-rotors configurations

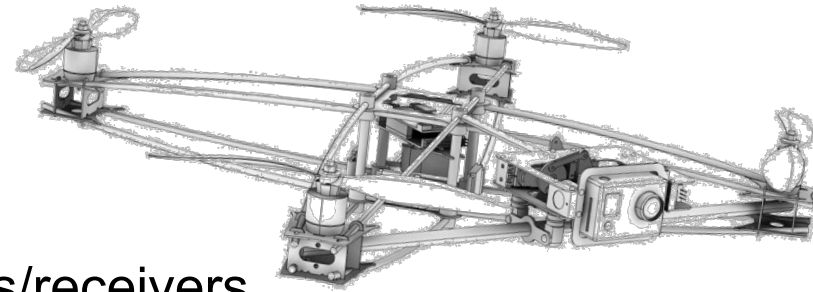

“Patrolling hawks”

- **High-altitude, High-Payload unmanned aerial vehicles**, patrolling a large area at high-altitude (50-100m) and complementing the capabilities of the small-scale UAVs.
- Constructing rough 3D maps of the rescuing area, serving as a communication hub.
- Fixed-wing, Rmax
- Complementarities with respect to the small scale UAVs (operational synergies)

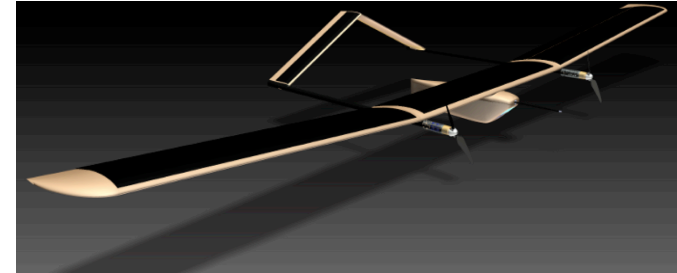

“Intelligent donkey”

- **Ground rover:** “intelligent” carrying vehicle equipped with a multi-functional robotic arm
- Recovering/re-charging base for the aerial vehicles, able to improve the operative radius and the overall autonomy of the combined system, carrying vehicle-20 Kg payload

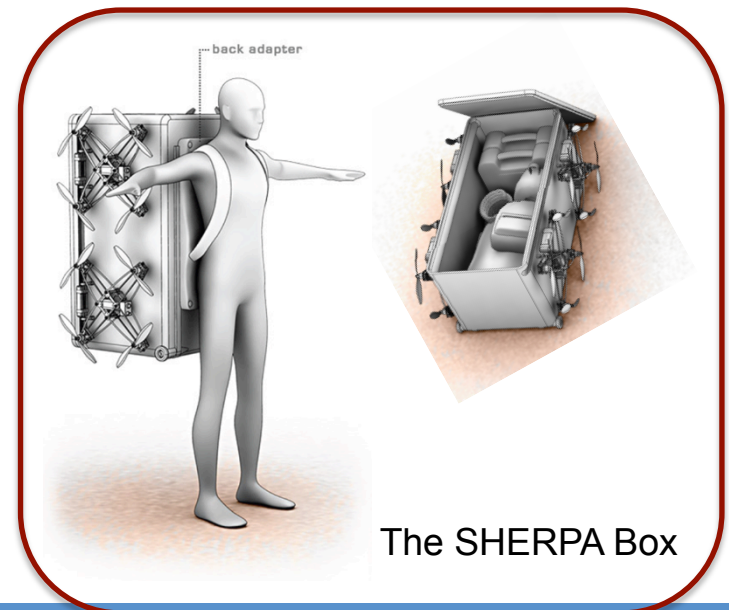
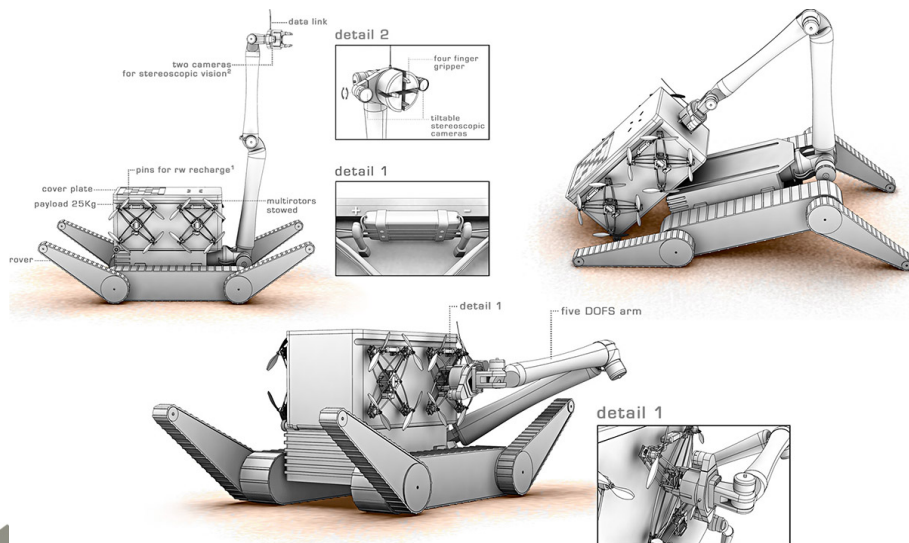



Interest in “wasps”

- Quadcopters equipped with cameras (RGB, thermal, ...) or other sensors
 - fast survey of “limited” areas
 - able to flight in a forest and scan areas with cameras (normal or thermal); feedback video for ground station; flying eyes for the rescuer
 - exploration of steep walls
 - rescue operations on cableways (cable cars)
 - avalanche
 - equipped with beacon
 - possible new (more efficient) search methods



Interest in “hawks”

- RMAX:
 - deployment of wasps to improve efficiency
 - Carry and deploy first aid kit for missing people (sleeping bag, medicines, thermos flask)
 - Radio/Wi-Fi/GSM bridge for not covered areas
 - Flying in the night with laser scanners when real helicopters cannot flight
- Fixed wing:
 - first and fast scan of incident area
 - Equipped with high resolution cameras could send images of the area to the ground station and with computer vision algorithms detect on snow proofs of potential victim (gloves, ski, backpacks)
 - Radio/Wi-Fi/GSM bridge for not covered areas



Interest in “donkeys”

- “Aircraft carrier”: docking and deployment station for wasps to increase efficiency and recharge batteries.
- Radio bridge. Almost fixed ground station with limited movements. Payload limited for batteries and hardware
- Useless in winter

- Mountains: a very challenging environment for SAR missions, with many complex operational scenarios
- Some of these scenarios have been outlined
- Robotic technology may help, and we have the vision, but ...

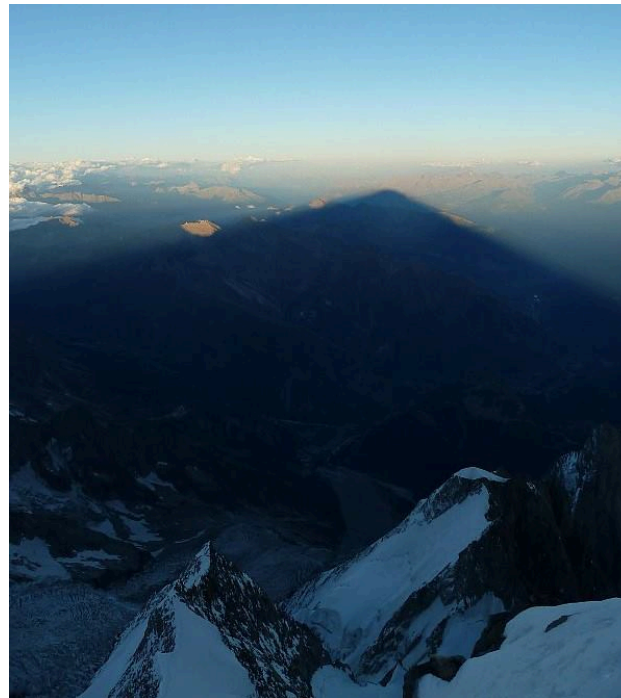

Application of Robotic Technologies to Mountain Rescue

Claudio Melchiorri

CAI — Italian Alpine Club
University of Bologna

